



Rodney Industries

APRIL 2024

CHANNEL GATES



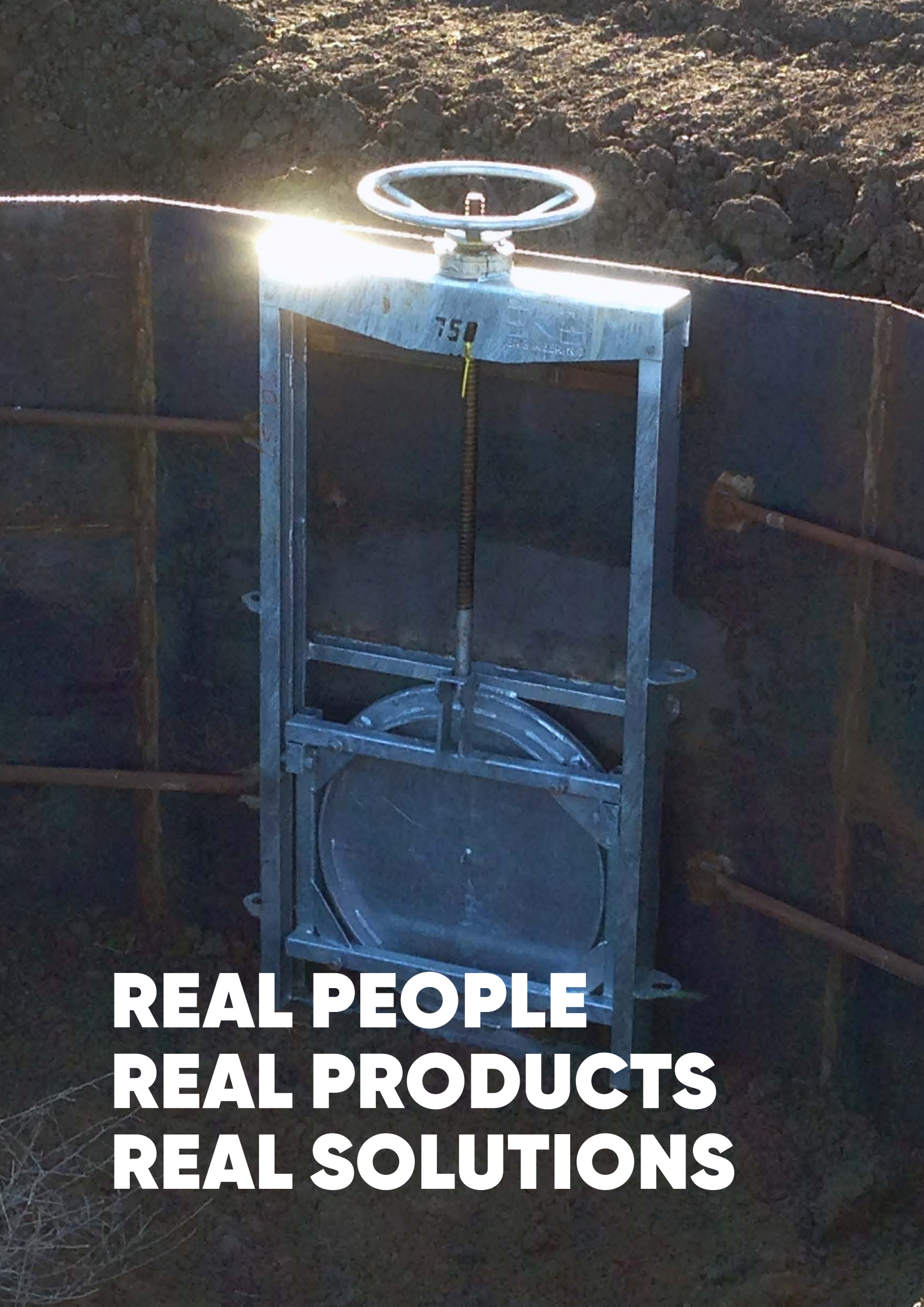

**REAL PEOPLE
REAL PRODUCTS
REAL SOLUTIONS**

INDEX

Introduction	PAGE 01
2 Metre Channel Gates	PAGE 05
4 Metre Channel Gates	PAGE 11
6 Metre Channel Gates	PAGE 21
10 Metre Channel Gates	PAGE 31
Instructions	PAGE 41

CHANNEL GATES

INTRODUCTION

The Rodney Industries Channel Gate is designed to offer years of trouble free service with its galvanized and stainless steel construction.

The Channel Gate is used in many installations from agricultural irrigation channelling, water storage dams, flood preventions to environmental protection controls. Rodney Industries channel gates can be supplied with standard or special spigots to enable a number of installation methods.

- Grout in Spigots to suit concrete pipes and headwalls
- Weld on Spigots to suit steel pipe or tanks
- Flanged Spigots to suit flanged pipes
- Compression rings to suit poly, steel or concrete pipe end fitments

A standard mast assembly is fitted to the gate as standard and special hand wheel to pipe centre dimensions can be supplied to customer requirements. Fluids or mediums other than water will need to be checked for compatibility with valves components.

Maximum working pressure of the standard channel gate referred to as head pressure above the valve. This measurement is taken as the height from the pipe centre of the valve spigot to the surface of the water storage. Rodney Industry valves have separate models to accommodate the following maximum head pressures.

- 2 Metre (low head)
- 4 Metre (high head)
- 6 Metre (high head)
- 10 Metre (high head)

The channel gates are designed to operate with on or off seating water flow directions and is designed to be opened fully to supply low form loss with its flap lifted clear of flow.

A durable floodgate rubber seal is fitted to the flap as a bolt in assembly and can be replaced if damage to the seal has occurred. Operating of the standard channel gate is with a screw thread mast assembly, 4:1 screw thread gearbox mast assembly or hydraulic cylinders mast assembly, all types of operation are optional on the channel gates.

CHANNEL GATES

There are many features that allow our Channel Gates to stand out from the competitors, here are just a few:



Fully Galvanised



Hand Wheel



Top Lock



Axle Roller



Mast Bearing



Flood Gate Seal



Bottom Lock



Spigot

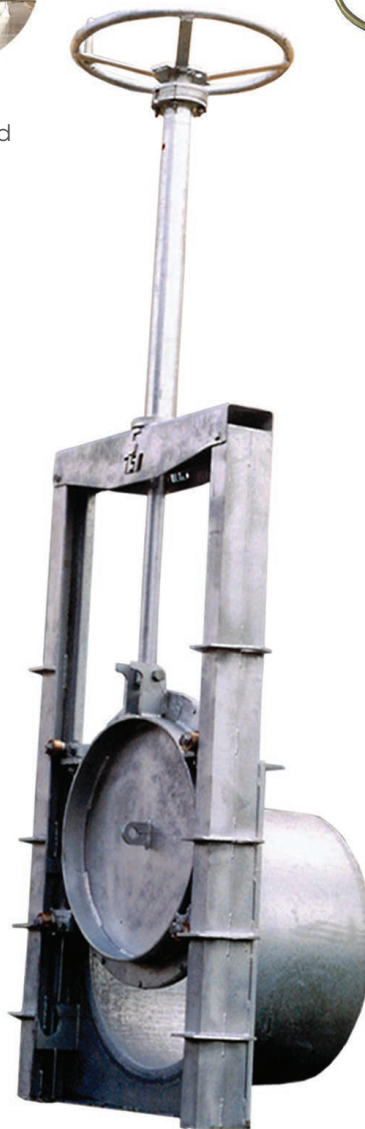

- 2, 4, 6 and 10 metre/head duty ratings
- Fully galvanized construction - Hot dipped
- Self aligning mast bearings - industry standard
- Manual reduction gear box and hydraulic available
- Negative and positive head capable (on or off seat)
- Fully enclosed threaded mechanism 4, 6 and 10 metres

- Wide variety of fitting methods, ie. Weld on, grout in, rubber seal, Pro Pipe socket, flange etc.
- Mast extensions to job requirements
- Over size sintered bushed roller locks
- Cam adjusted phosphor bronze rollers guide rollers on all models.
- Stainless Steel Axles and Stainless Steel Rollers

CHANNEL GATES

NEED A CHANNEL GATE BUT UNSURE AS TO WHICH GATE WILL BEST SUIT YOUR PROJECT REQUIREMENTS?

The following is a breakdown of sizes and options available throughout our Channel Gate range. The image below is based upon a standard 6 metre gate. For further information on individual sizing, please refer to the product details.

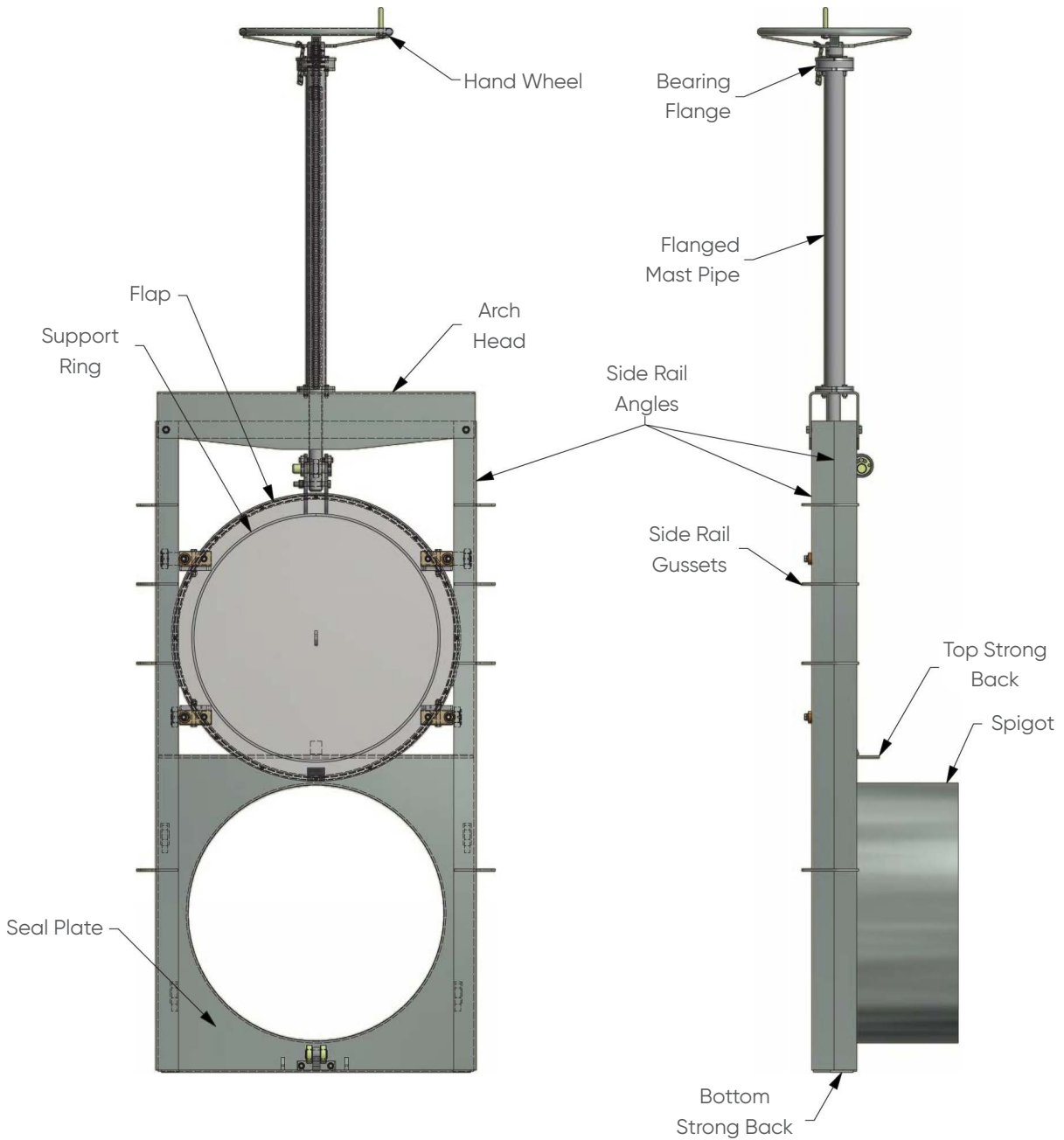

CHANNEL GATES

GATE SIZE

We understand that not every installation is the same, and it is for that reason, we have one of the largest range of Channel Gate sizes available:

- 450mm
- 500mm
- 600mm
- 750mm
- 900mm
- 1050mm
- 1200mm
- 1350mm
- 1500mm
- 1650mm
- 1800mm

HOW WILL IT BE ATTACHED?

Rodney Industries Channel Gates can be supplied with standard or special spigots to enable a number of installation methods:

- Grout in Spigots to suit concrete pipes and head walls
- Weld on Spigots to suit steel pipe or tanks
- Flanged Spigots to suit flanged pipes
- Compression rings to suit poly, steel or concrete pipe end fittings.

MAST & MAST EXTENSIONS

Mast and Mast Extensions are fitted so that the hand heel height is at a suitable operating level.

Our Channel Gates can be manufactured to your mast requirements.

HEAD SIZE

The maximum working pressure of the standard Channel Gate is referred to as head pressure above the valve.

This measurement is taken as the height from the pipe centre of the valve spigot to the surface of the water storage.

Rodney Industry valves have separate models to suit the following maximum head pressures.

- 2 metre
- 4 metre
- 6 metre
- 10 metre

HEADWALL MOUNTING BRACKETS

Headwall mounting brackets are available as an option for all gates and are advised for compression seal spigot installations. Flange spigot hole positions can vary to different flange types and ratings and should be checked to ensure that this orientation can be achieved.

The Channel Gate should not be stressed or strained back to an uneven surface as this can affect its ability to seal, headwall mounting brackets are designed to be used with nuts and washers on both sides of the bracket to keep the gate stress free.

FURTHER OPTIONS

Further options for consideration are as follows:

- Mast Stabilizer Brackets
- Gate Open Indicator
- Turning Mechanism:
- Handle or Hydraulic cylinder
- Gear Reduction (only when head > 4mtrs on 1500mm to 1800mm sizes).

Built by Aussies for Aussie Conditions



Rodney **Industries**



When it comes to investing in Channel Gates look no further than the quality, durability, and experience of Rodney Industries.

Manufactured onsite in our Brisbane warehouse we also offer a range of Eco Check Valves, Gibault Joints and Suction Tapers.

If you have a project that requires a valve out of the ordinary, look no further than Rodney Industries. With our Sales and Design team, we are sure to find the solution to your requirements.



RODNEY INDUSTRIES

19 Valente Close Chermside QLD 4032

P: 07 3624 0300

e: sales@rodneyind.com.au

w: www.rodneyind.com.au

CHANNEL GATES

2 METRE STANDARD LOW HEAD

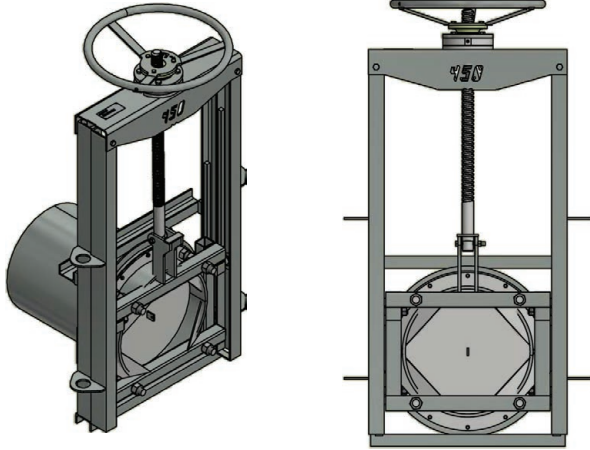

STANDARD FEATURES

- Mast Bearing
- Self aligning spherical roller
- Axle Rollers
- Phosphor bronze rollers
- On and off seating duty
- Stainless Steel Axle

2 Metre Low Head Application On and Off Seating Duty

Size (mm)	Spigot Length (mm) x thickness (mm)	Spigot Centre to Handweel (mm)	Pipe Centre to Base (mm)	Overall Width (mm)	Std Gate Weight (kg)	Grout In Spigot Code	Weld on Spigot Code	Price
450	450 x 6	1135	320	640	120	G2450GIS	G2450WOS	5,925.40
500	450 x 6	1200	345	690	134	G2500GIS	G2500WOS	6,020.80
600	450 x 6	1355	395	790	160	G2600GIS	G2600WOS	6,195.70
750	450 x 6	1630	472	945	195	G2750GIS	G2750WOS	6,794.60
900	450 x 6	1816	545	1089	240	G2900GIS	G2900WOS	7,208.00
1050	450 x 6	2000	620	1239	281	G21050GIS	G21050WOS	8,034.80
1200	450 x 6	2300	700	1390	340	G21200GIS	G21200WOS	10,043.50
1500	450 x 6	2900	860	1870	780	G21500GIS	G21500WOS	17,251.50
1800	450 x 6	3403	1010	2170	1000	G21800GIS	G21800WOS	19,557.00

OPTIONS

Description	Code	Price
For mast height extensions, please contact our office		
Mast stabilizer bracket	CGE002	197.40
Headwall mounting bracket	CGE003	285.30
Non Standard Spigots	CGE004	P.O.A

CHANNEL GATES

2 METRE GENERAL ASSEMBLY

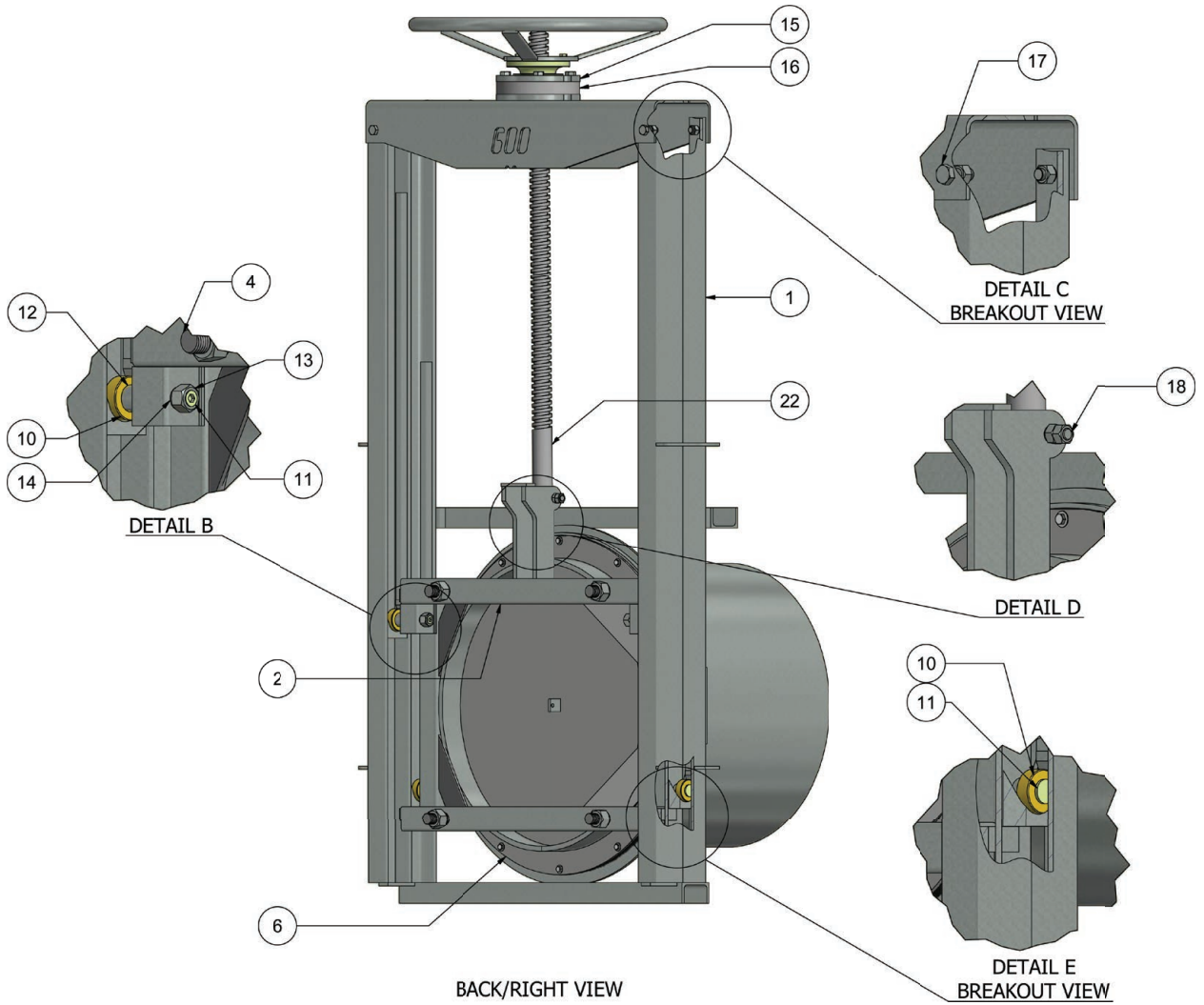

CHANNEL GATES

2 METRE GENERAL ASSEMBLY

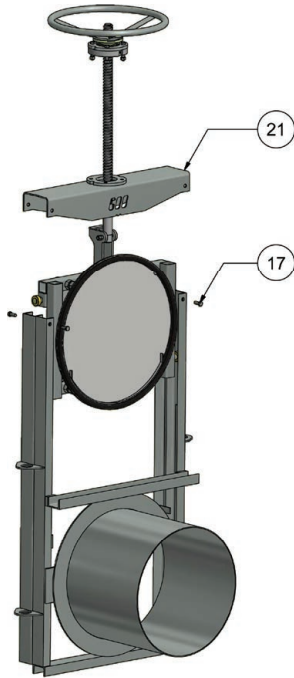

FLAP REMOVAL VIEW

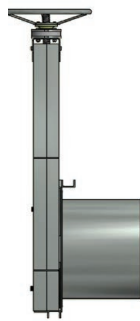

RIGHT SIDE VIEW

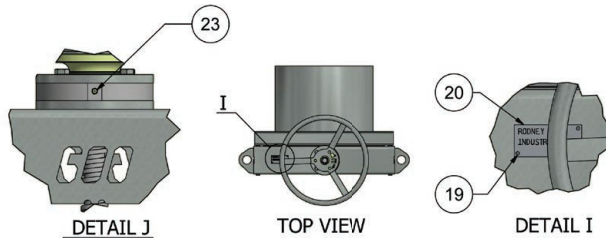

DETAIL J

TOP VIEW

DETAIL I

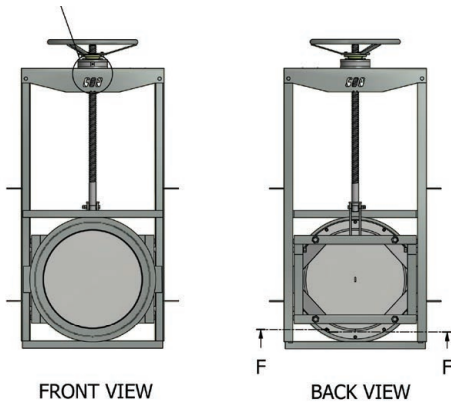

FRONT VIEW

BACK VIEW

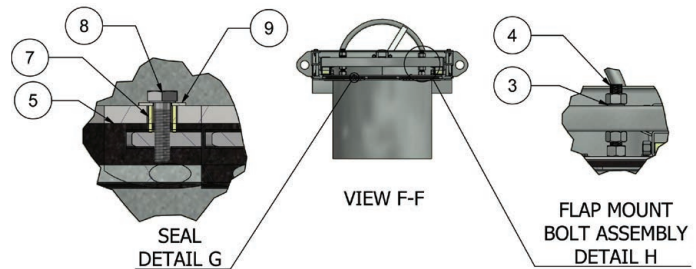

SEAL
DETAIL G

VIEW F-F

FLAP MOUNT
BOLT ASSEMBLY
DETAIL H

Item	Qty	Description
1	1	Body Kit Galv
2	1	Flap Frame
3	4	Flap Frame Bolt Spring Washer
4	4	Flap Frame Bolt & Nut
5	1	Flap Seal
6	1	Flap
7	12	Spacer Flap Seal
8	12	Seal Bolt
9	12	Seal Bolt Washer
10	4	Axle Roller
11	4	Axle
12	4	Axle Spacer
13	4	Axle Nut
14	4	Axle Spring Washer
15	1	Bearing Retainer Flange
16	1	Bearing Housing
17	4	Arch Bolt & Nut
18	1	Push Eye Bolt & Nut
19	2	ID Tag Rivet
20	1	ID Tag
21	1	Arch Head
22	1	Threaded Shaft
23	1	Grease Nipple

CHANNEL GATES

2 METRE GENERAL ASSEMBLY

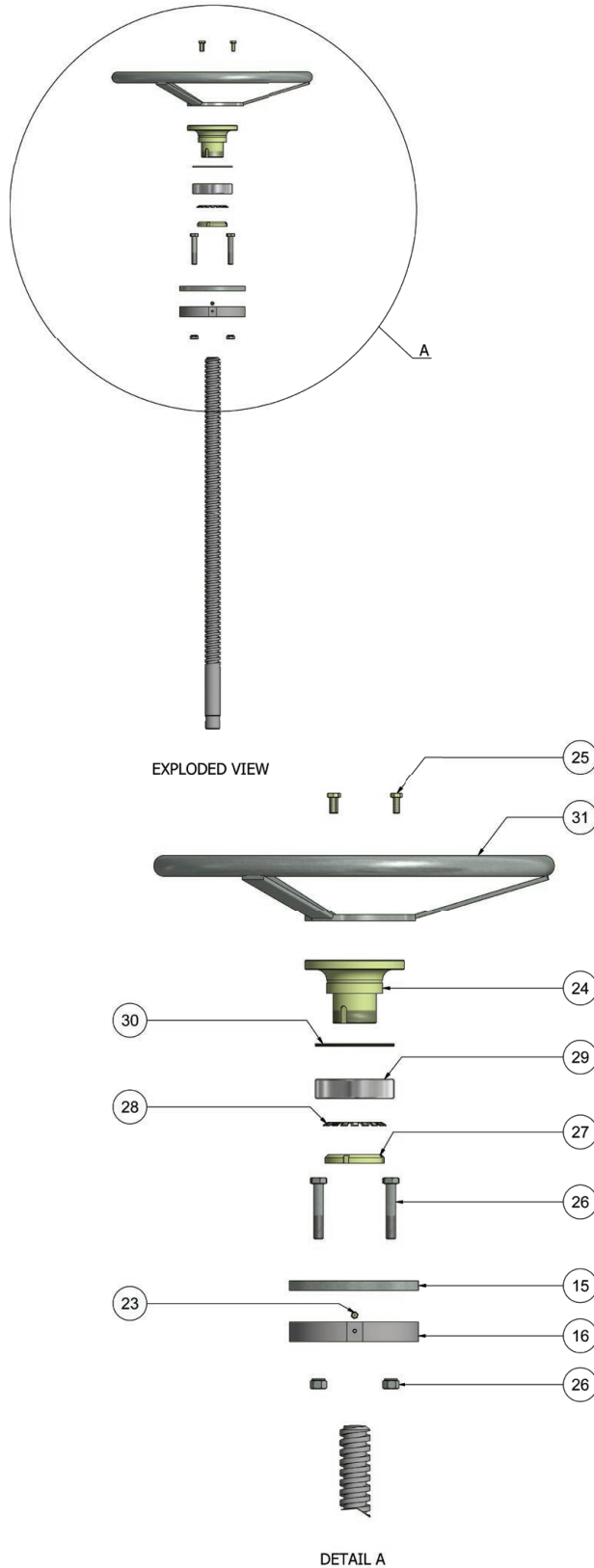

Item	Qty	Description
15	1	Bearing Retainer Flange
16	1	Bearing Housing
23	1	Grease Nipple
24	1	Exposed Thread Nut
25	3	Hand Wheel Bolt
26	4	Bearing Housing Bolt & Nut
27	1	Bearing Lock Nut
28	1	Bearing Lock Washer
29	1	Mast Bearing
30	1	Poly Seal Ring
31	1	Hand Wheel



TOP VIEW



FRONT VIEW

CHANNEL GATES

2 METRE GENERAL ASSEMBLY

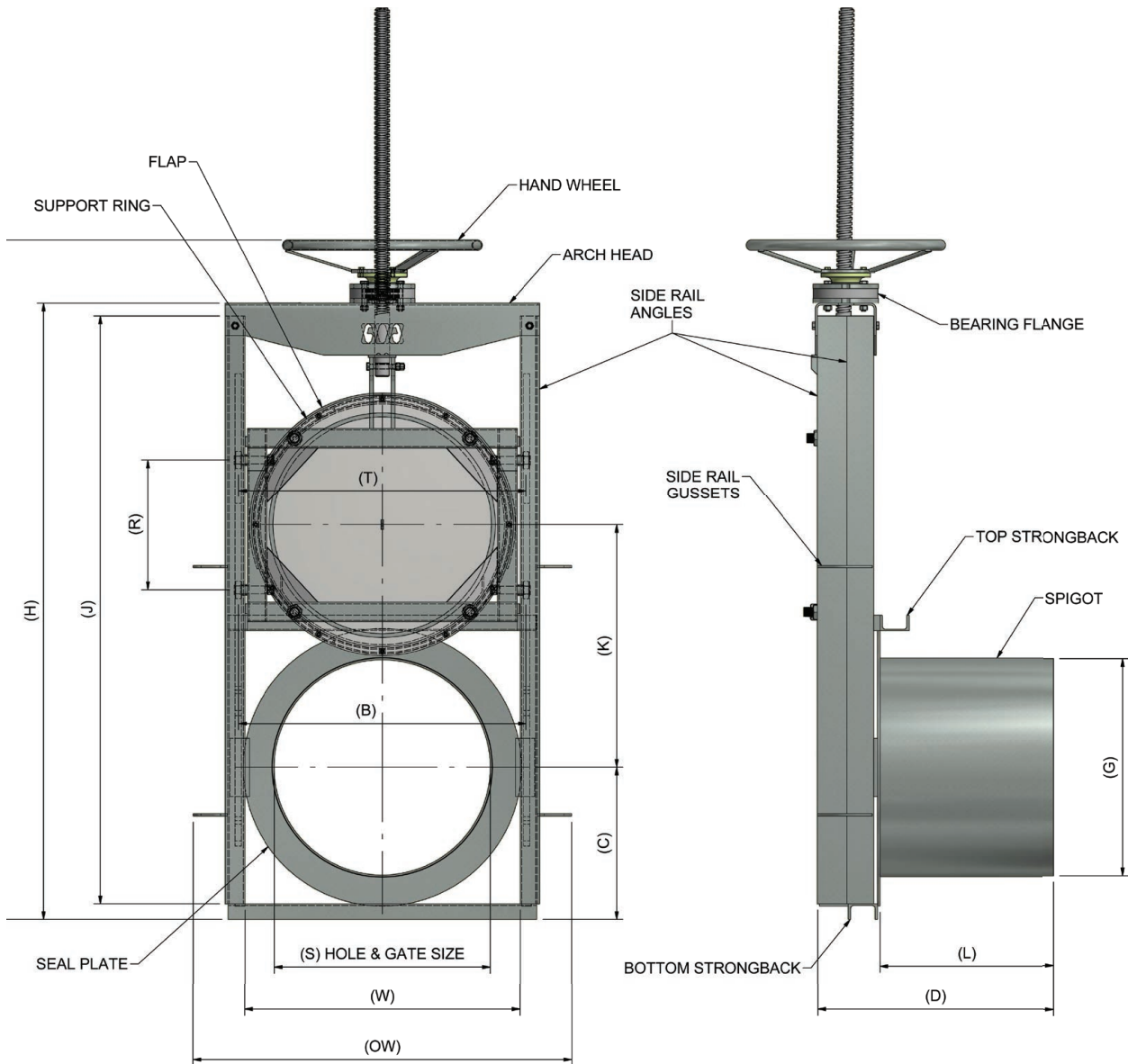

CHANNEL GATES

CHANNEL GATES

2 METRE SPECIFICATIONS

G2 HW to SPIGOT CTR	
450	1135
500	1200
600	1355
750	1630
900	1816
1050	2000
1200	2300
1500	2900
1800	3403
1650	5116
1800	5581

GATE SIZE (S)	OVERALL HEIGHT (OH)	HEIGHT (H)	OVERALL WIDTH (OW)	DEPTH (D)	BASE TO C/L HOLE (C)	STROKE TO FULLY OPEN (K)	SIDE RAIL LENGTH (J)	WIDTH BETWEEN SIDE RAILS (W)	AXLE CENTRES (R)	TOP ROLL-ER APART (T)	BOT ROLL-ER APART (B)	SPIGOT DIA O.D. GROUT (G)	SPIGOT DIA I.D. WELD (G)	SPIGOT LENGTH (L)	GUSSETS PER SIDE
600	1745	1582	968	604	390	620	1509	712	342	736	736	560	600	4444	2
750	2057	1894	1117	604	465	770	1785	855	416	886	886	710	750	4444	2
900	2339	2176	1264	604	540	924	2067	1002	490	1036	1036	865	900	4444	2
1050	2609	2445	1414	604	613	1069	2341	1152	560	1202	1202	1016	1050	4444	2
1200	2896	2733	1565	604	693	1222	2623	1301	635	1336	1336	1150	1200	4444	2
1350	3744	3562	1890	712	860	1520	3416	1620	694	1648	1648	1300	1350	450	2
1500	3744	3562	1890	712	860	1520	3416	1620	694	1648	1648	1474	1500	450	3
1650	4400	4218	2190	720	1010	1826	4021	1920	831	1948	1948	1626	1650	450	3
1800	4400	4218	2190	720	1010	1826	4021	1920	831	1948	1948	1778	1800	450	3

CHANNEL GATES

4 METRE STANDARD MEDIUM HEAD

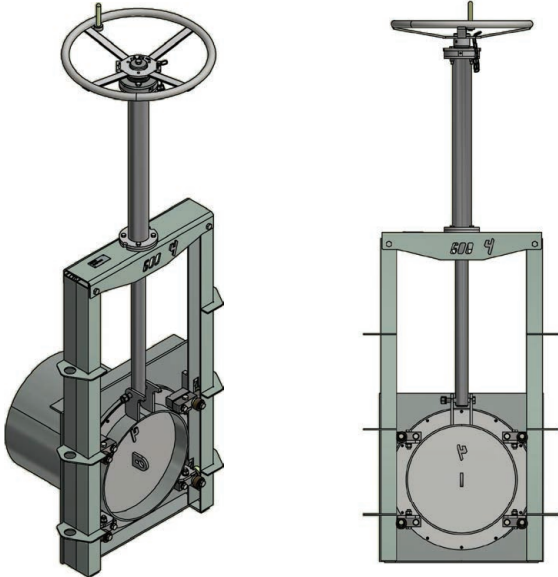

STANDARD FEATURES

- Top Lock
- A large diameter adjustable roller sintered bronze bearing
- Bottom Lock
- Two large diameter rollers with sintered bronze bearings
- Axle Rollers
- Large diameter rollers with sintered bronze bearings
- Door Guide
- Cam adjusted phosphor bronze rollers
- Hydraulic Cylinders
- Heavy duty industrial flange mounted

4 Metre Low Head Application On and Off Seating Duty

Size (mm)	Spigot Length (mm) x thickness (mm)	Spigot Centre to Handwheel (mm)	Pipe Centre to Base (mm)	Overall Width (mm)	Std Gate Weight (kg)	Grout In Spigot Code	Weld on Spigot Code	Price
450	450 x 6	1902	356	820	253	G4450GIS	G4450WOS	9,497.60
500	450 x 6	1902	356	820	253	G4500GIS	G4500WOS	9,587.70
600	450 x 6	2234	406	920	285	G4600GIS	G4600WOS	10,626.50
750	450 x 6	2574	481	1070	344	G4750GIS	G4750WOS	11,607.00
900	450 x 6	2980	556	1220	498	G4900GIS	G4900WOS	11,856.10
1050	450 x 6	3507	631	1370	627	G41050GIS	G41050WOS	14,394.80
1200	450 x 6	3905	706	1520	685	G41200GIS	G41200WOS	17,007.70
1350	450 x 6	4309	781	1670	830	G41350GIS	G41350WOS	18,279.70
1500	450 x 6	4639	856	1890	950	G41500GIS	G41500WOS	20,415.60
1650	450 x 6	5130	931	2050	1395	G41650GIS	G41650WOS	24,947.10
1800	450 x 6	5518	1025	2190	1710	G41800GIS	G41800WOS	25,153.80

OPTIONS

Description	Code	Price
For most height extensions, please contact our office		
Gate open indicator	CGE001	P.O.A
Mast stabilizer bracket, each	CGE002	197.40
Headwall mounting bracket, each	CGE003	285.30
Non Standard Spigots	CGE004	P.O.A

CHANNEL GATES

4 METRE HYDRAULIC MEDIUM HEAD

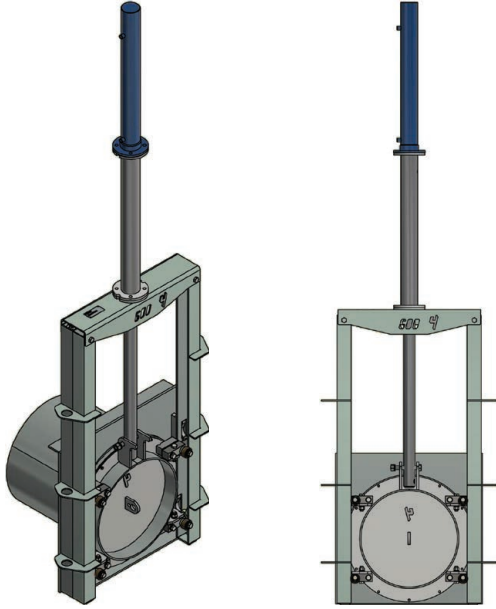

STANDARD FEATURES

- Top Lock
- A large diameter adjustable roller sintered bronze bearing
- Bottom Lock
- Two large diameter rollers with sintered bronze bearings
- Axle Rollers
- Large diameter rollers with sintered bronze bearings
- Door Guide
- Cam adjusted phosphor bronze rollers
- Hydraulic Cylinders
- Heavy duty industrial flange mounted

4 Metre Medium Head Application On and Off Seating Duty

Size (mm)	Spigot Length (mm) x thickness (mm)	Spigot Centre to Handwheel (mm)	Pipe Centre to Base (mm)	Overall Width (mm)	Std Gate Weight (kg)	Grout In Spigot Code	Weld on Spigot Code	Price
450	450 x 6	1742	356	820	269	G4450HGIS	G4450HWOS	11,458.60
500	450 x 6	1742	356	820	270	G4500HGIS	G4500HWOS	11,649.40
600	450 x 6	2017	406	920	303	G4600HGIS	G4600HWOS	12,847.20
750	450 x 6	2414	481	1070	371	G4750HGIS	G4750HWOS	14,924.80
900	450 x 6	2820	556	1220	528	G4900HGIS	G4900HWOS	14,612.10
1050	450 x 6	3437	631	1370	664	G41050HGIS	G41050HWOS	16,525.40
1200	450 x 6	3745	706	1520	726	G41200HGIS	G41200HWOS	19,519.90
1350	450 x 6	4149	781	1670	886	G41350HGIS	G41350HWOS	20,935.00
1500	450 x 6	4464	856	1890	1024	G41500HGIS	G41500HWOS	23,744.00
1650	450 x 6	4961	931	2050	1475	G41650HGIS	G41650HWOS	28,328.50
1800	450 x 6	5331	1025	2190	1820	G41800HGIS	G41800HWOS	30,300.10

OPTIONS

Description	Code	Price
For most height extensions, please contact our office		
Gate open indicator	CGE001	P.O.A
Mast stabilizer bracket, each	CGE002	197.40
Headwall mounting bracket, each	CGE003	285.30
Non Standard Spigots	CGE004	P.O.A

CHANNEL GATES

4 METRE GENERAL ASSEMBLY

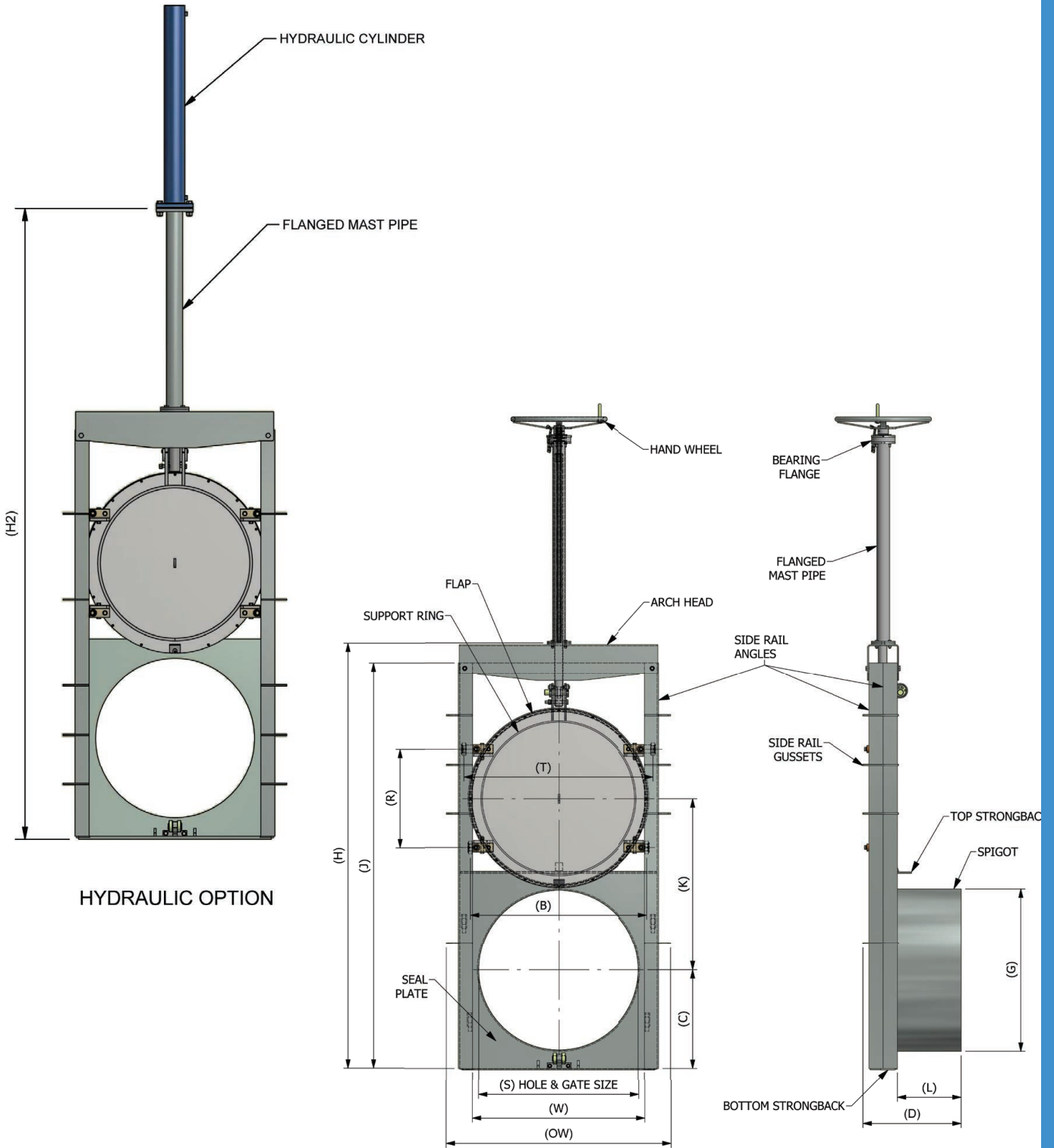

CHANNEL GATES

4 METRE SPECIFICATIONS

CHANNEL GATES

GATE SIZE (S)
450
500
600
750
900
1050
1200
1350
1500
1650
1800

HW to SPIGOT CTR (GB)	
450	1918
500	1916
600	2170
750	2580
900	2980
1050	3453
1200	3906
1350	4309
1500	4700
1650	5116
1800	5581

GATE SIZE (S)	BASE TO C/L HOLE (C)	STROKE TO FULLY OPEN (K)	SIDE RAIL LENGTH (J)	WIDTH BETWEEN SIDE RAILS (W)	AXLE CEN-TRES (R)	TOP ROLLER APART (T)	BOTTOM ROLLER APART (B)	SPIGOT DIA. O.D GROUT (G)	SPIGOT DIA. I.D WELD (G)	SPIGOT LENGTH (L)	GUSSETS PER SIDE	HEIGHT (H)	OVERALL WIDTH	DEPTH (D)
450	345	535	1330	518	360	608	543	406	450	450	3	1378	830	652
500	345	535	1330	518	360	608	543	484	500	450	3	1378	832	652
600	395	635	1530	618	414	708	643	560	600	450	3	1581	930	654
750	445	785	1839	768	500	858	793	710	750	450	3	1919	1082	654
900	545	935	2159	918	520	1008	943	865	900	450	3	2246	1224	654
1050	620	1085	2525	1068	588	1158	1093	1016	1050	450	3	2542	1372	658
1200	695	1235	2870	1218	700	1340	1250	1150	1200	450	3	3019	1588	691
1350	770	1385	3165	1368	773	1490	1400	1300	1350	450	3	3348	1738	692
1500	845	1535	3478	1518	838	1640	1550	1474	1500	450	4	3693	1888	692
1650	920	1685	3765	1668	960	1730	1700	1626	1650	450	4	4005	2038	696
1800	995	1835	4114	1818	1000	1940	1850	1778	1800	450	4	4382	2188	696

CHANNEL GATES

4 METRE GENERAL ASSEMBLY

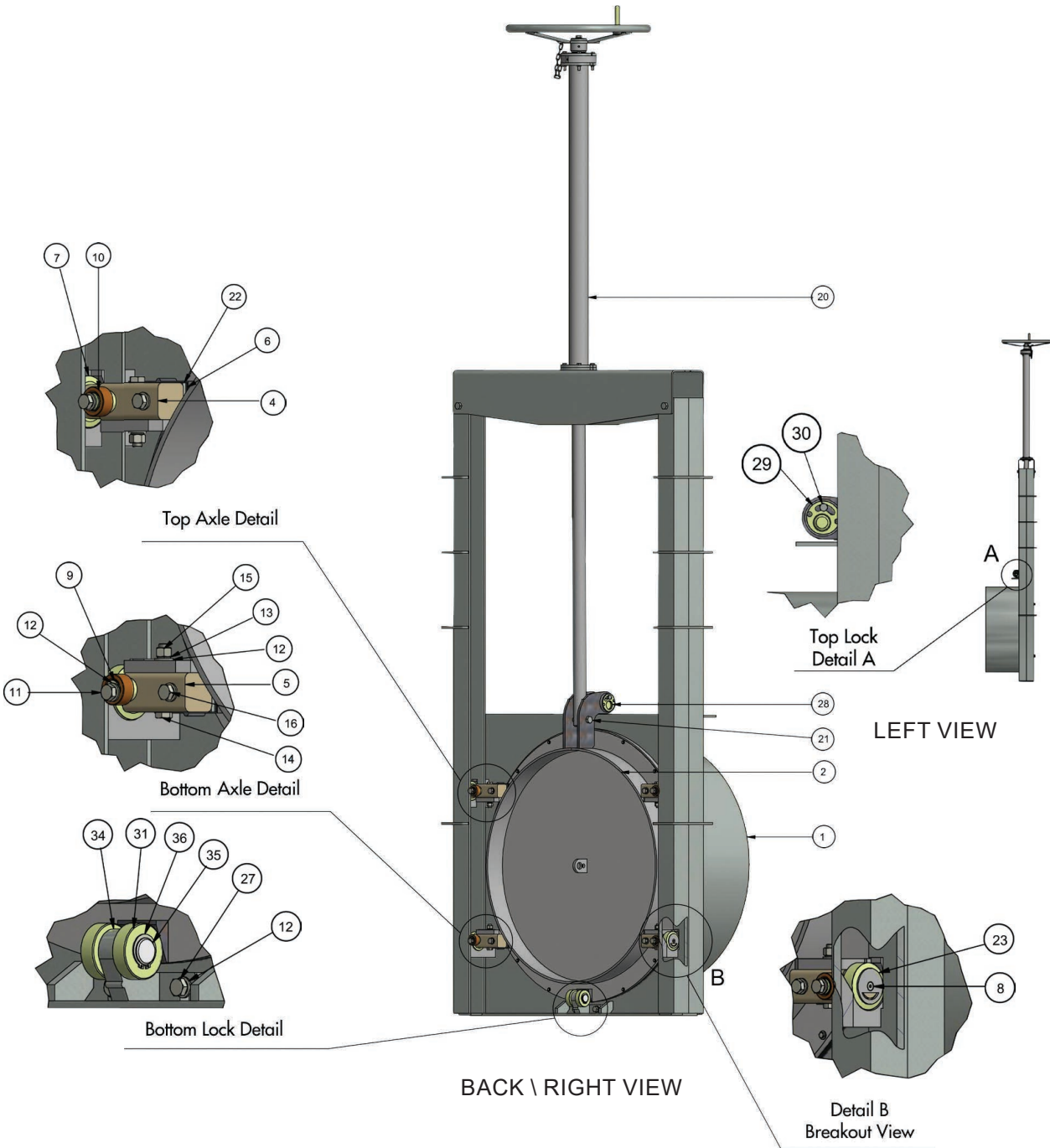

CHANNEL GATES

4 METRE GENERAL ASSEMBLY

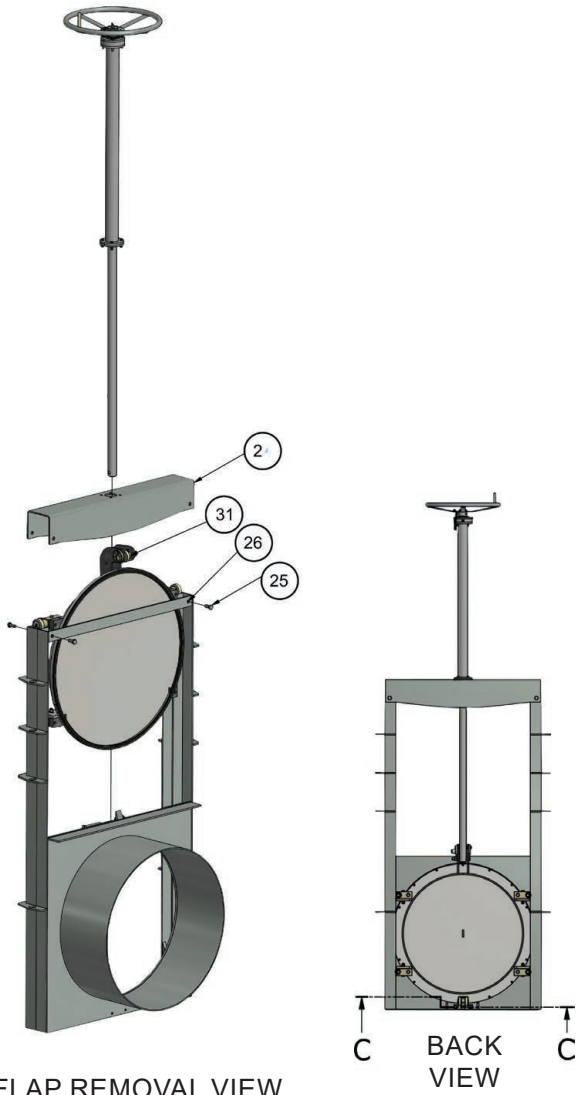

FLAP REMOVAL VIEW

BACK VIEW

VIEW C - C

Item	Qty	Description
1	1	Body Kit Galv
2	1	Flap Kit Galv
3	1	Flap Seal C/W Ring And Rubber
4	2	Long Axle Z/P
5	2	Short Axle Z/P
6	8	AXLE SHIM 2mm GALV
7	4	Axle Roller Bushed Z/P
8	4	Retainer Washer Bolt C/Sunk Head S/S 316
9	4	Cam Side Guide Roller Z/P
10	4	Guide Roller Bronze
11	4	Axle Cam Bolt S/S
12	14	Washer Flat S/S 316
13	14	Washer Spring S/S 316
14	4	Axle Cross Bolt S/S 316
15	4	Axle Cross Bolt Nut
16	4	Axle Bolt S/S 316
17	16	Seal Bolt S/S 316
18	16	Seal Bolt Washer S/S 316
19	16	Flap Seal Spacer
20	1	Mast Kit
21	1	Push Pipe Clevis Bolt
22	4	Axle Shim 8mm Galv
23	4	Axle Retaining Washer
24	1	Arch Head
25	4	Arch Head Bolt Assembly Galv
26	4	Arch Head Spring Washer

Channel Gate Size Dependent Parts		
Item	Qty	Description
27	2	Bottom Lock Bolt S/S 316
28	1	Top Lock Cam Pin Z/P
29	1	Top Lock Cam Disc Z/P
30	2	Top Lock Cam Bolt Assembly Galv
31	3	Top & Bottom Lock Roller
32	1	Bottom Lock Shim 4mm Galv
33	2	Bottom Lock Shim 2mm Galv
34	1	Bottom Lock Welded
35	1	Bottom Lock Pin
36	2	Circlip Bottom Lock Roller

Hydraulic Option		
Item	Qty	Description
37	1	Hydraulic Cylinder
38	1	Hydraulic Mast Pipe Outer
39	1	Hydraulic Push Pipe Inner

CHANNEL GATES

4 METRE MAST KIT

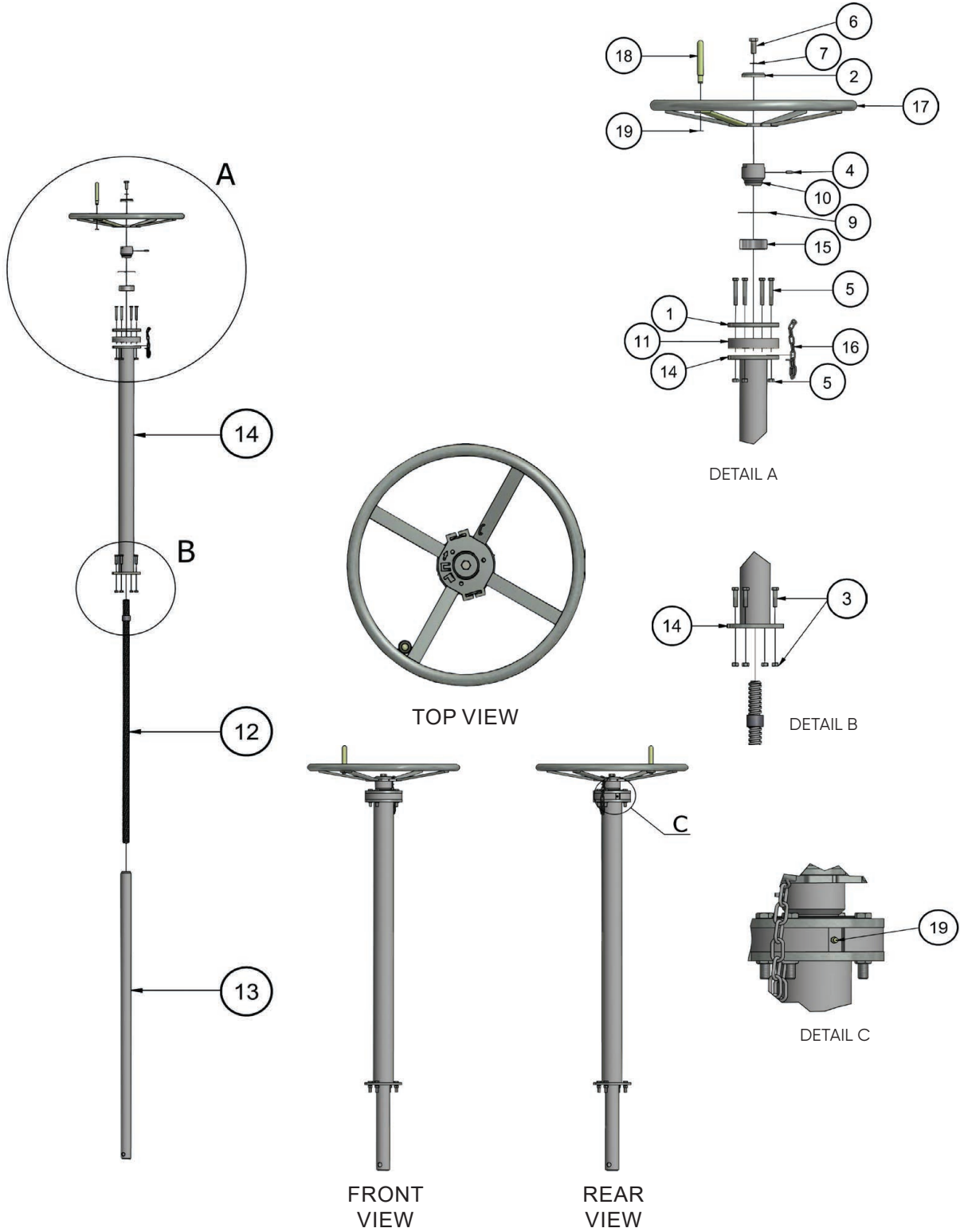

CHANNEL GATES

4 METRE HYDRAULIC OPTION

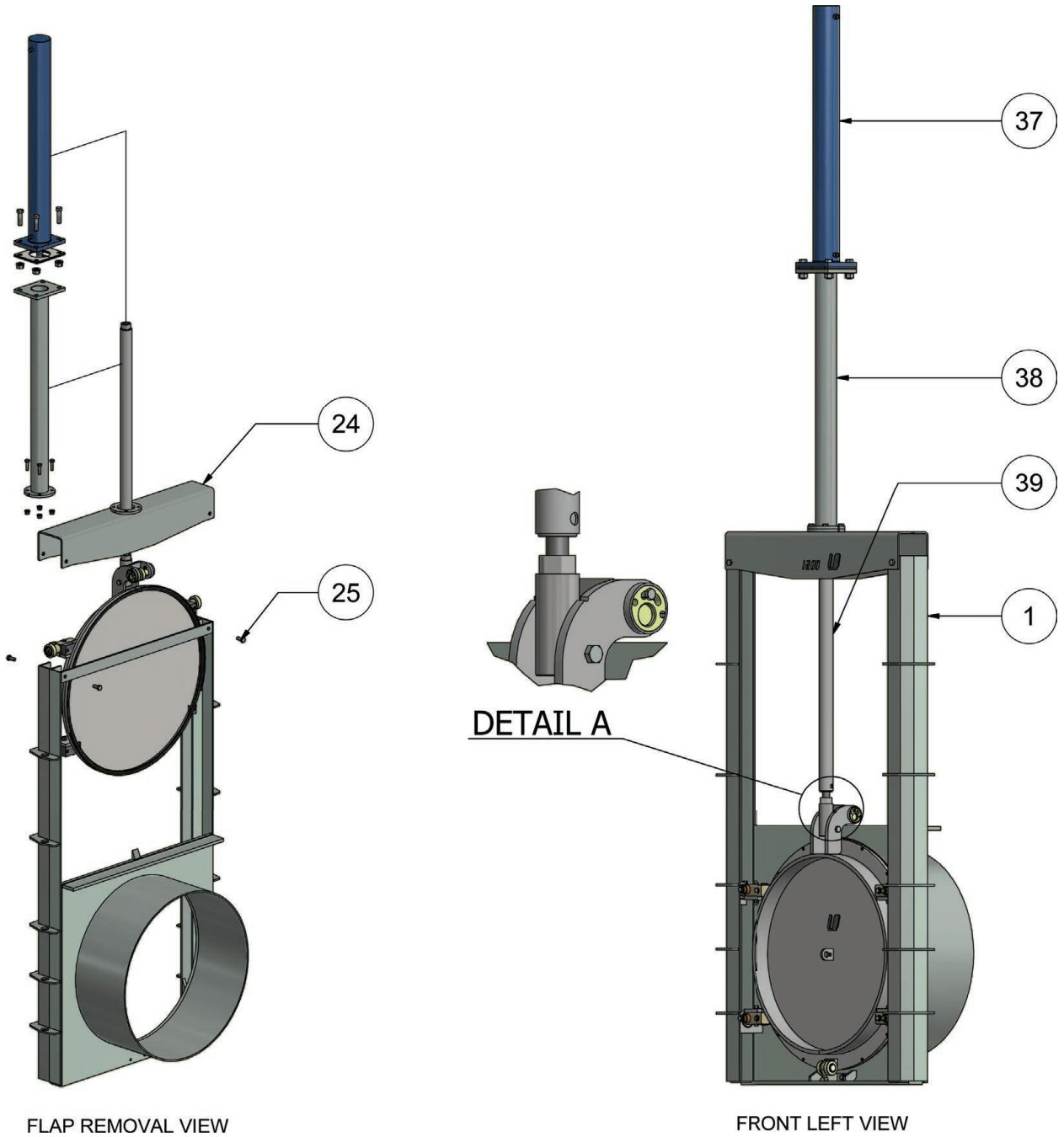

CHANNEL GATES

4 METRE HYDRAULIC MAST OPTION

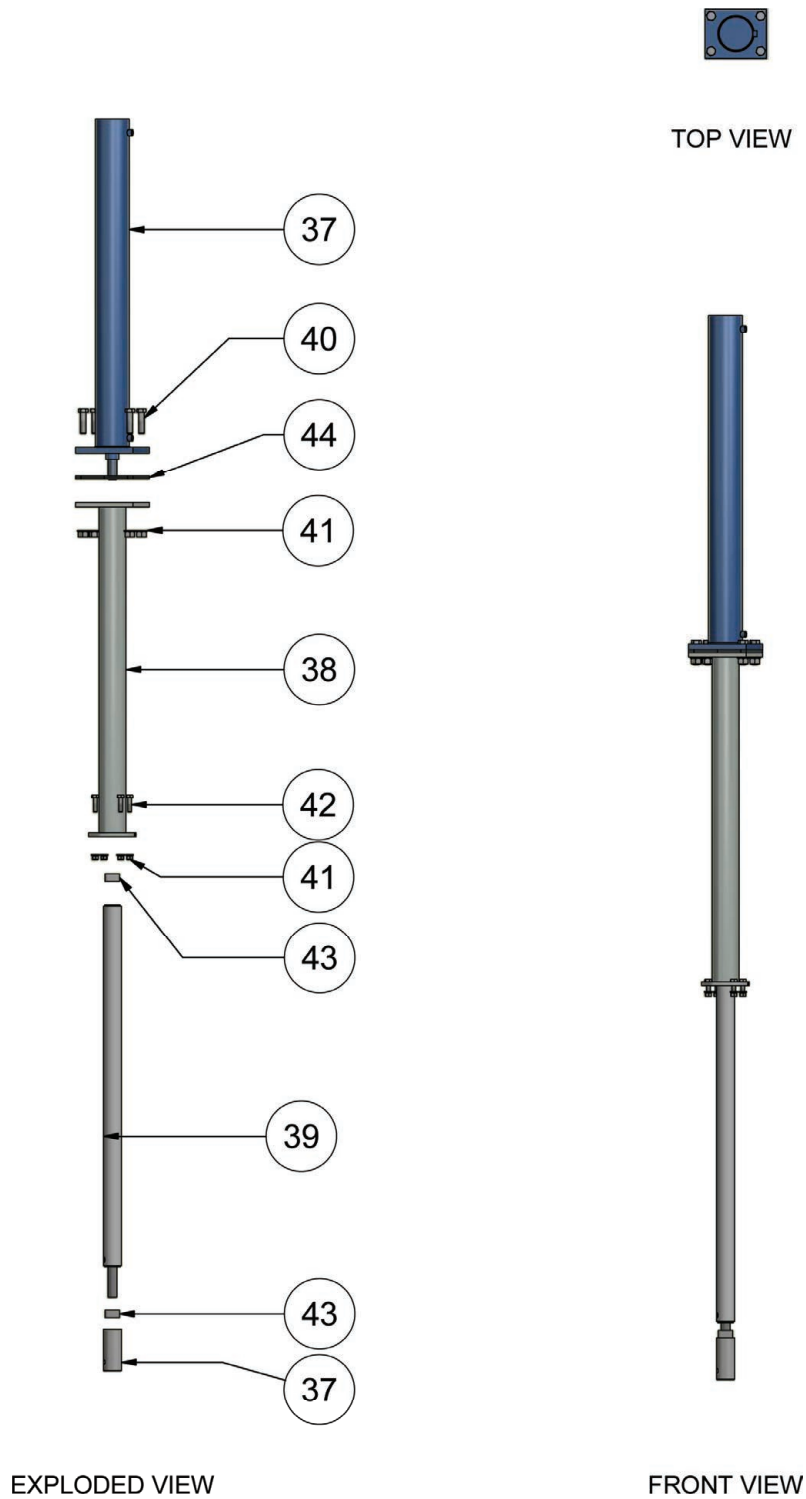

CHANNEL GATES

4 METRE GEAR REDUCTION MAST OPTION

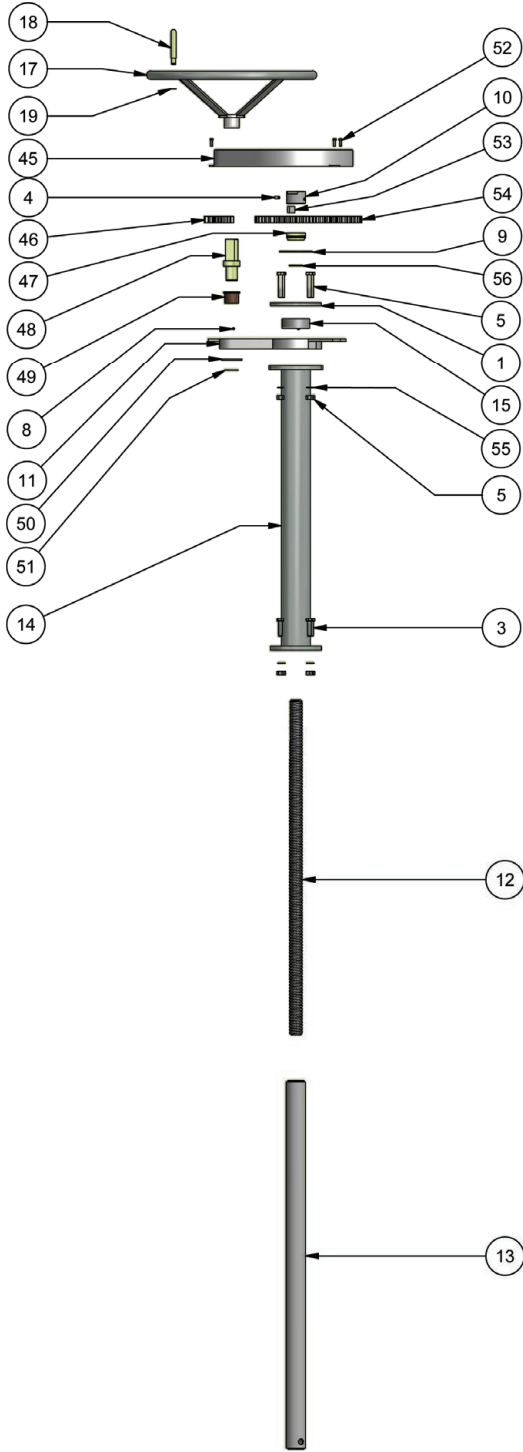

FRONT VIEW

Item	Qty	Description
1	1	Bearing Retainer Flange Gal
2	1	Hand Wheel Washer Gal
3	4	Mast Pipe Bolts
4	1	Lock Screw
5	4	Bearing Housing Bolt & Nut Assy
6	1	Hand Wheel Bolt
7	1	Hand Wheel Bolt Washer
8	1	Grease Nipple
9	1	Poly Seal Ring
10	1	Lock Nut Hand Wheel
11	1	Bearing Housing
12	1	Threaded Shaft
13	1	Mast Push Pipe Inner
14	1	Mast Pipe Outer
15	1	Mast Bearing
16	1	Keeper Chain
17	1	Hand Wheel
18	1	Hand Wheel Handle
19	1	Handle Circlip
37	1	Hydraulic Cylinder with Clevis
38	1	Hydraulic Mast Pipe Outer
39	1	Hydraulic Push Pipe Inner
40	4	Hydraulic Cylinder Bolt & Nut Assembly
41	4	Spring Washer
42	4	Hydraulic Mast Pipe Bolt & Nut Assembly
43	2	Clevis Lock Nut
44	4	Hydraulic Cylinder Packer 6mm Half Piece
45	1	Gearbox Cover
46	1	Small Gear to Suit Gearbox
47	1	Spacer
48	1	Pinion Shaft
49	1	Bush Sinterlite
50	1	Washer Flat Zinc Plated
51	1	Pinion Shaft Circlip
52	3	Gearbox Cover Set Screw
53	1	Threaded Shaft Lock Key
54	1	Large Gear to Suit Gearbox
55	4	Spring Washer
56	1	Circlip

CHANNEL GATES

6 METRE STANDARD HIGH HEAD

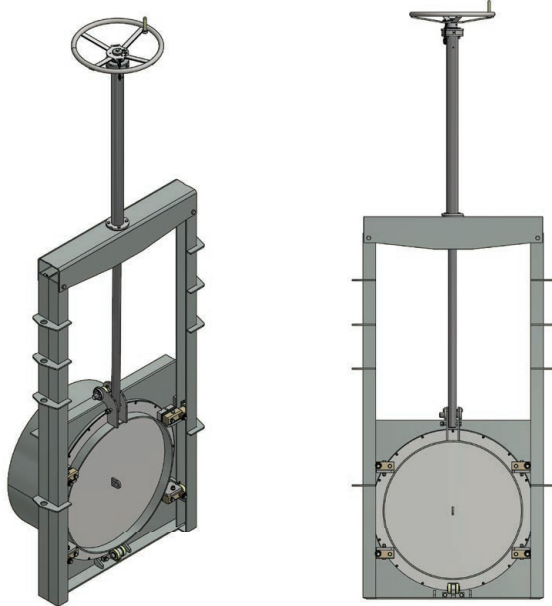

STANDARD FEATURES

- Mast Bearing
- Self-aligning spherical roller
- Top Lock
- A large diameter adjustable roller sintered bronze bearing
- Bottom Lock
- Two large diameter rollers with sintered bronze bearings
- Axle Rollers
- Large diameter rollers with sintered bronze bearings
- Door Guide
- Cam adjusted phosphor bronze rollers
- Handwheel
- Large diameter conventional style

6 Metre High Head Application On and Off Seating Duty

Size (mm)	Spigot Length (mm) x thickness (mm)	Spigot Centre to Handweel (mm)	Pipe Centre to Base (mm)	Overall Width (mm)	Std Gate Weight (kg)	Grout In Spigot Code	Weld on Spigot Code	Price
450	450 x 8	1902	356	820	330	G6450GIS	G6450WOS	9,948.10
500	450 x 8	1902	356	820	332	G6500GIS	G6500WOS	10,292.60
600	450 x 8	2234	406	920	388	G6600GIS	G6600WOS	10,796.10
750	450 x 8	2574	481	1070	474	G6750GIS	G6750WOS	12,253.60
900	450 x 8	2980	556	1220	620	G6900GIS	G6900WOS	13,578.60
1050	450 x 8	3507	631	1370	801	G61050GIS	G61050WOS	16,885.80
1200	450 x 8	3905	706	1520	918	G61200GIS	G61200WOS	17,876.90
1350	450 x 8	4309	781	1670	1075	G61350GIS	G61350WOS	20,553.40
1500	450 x 8	4639	856	1890	1233	G61500GIS	G61500WOS	24,342.90
«1650	450 x 8	5130	931	2050	1717	G61650GIS	G61650WOS	27,157.20
«1800	450 x 8	5518	1025	2190	1890	G61800GIS	G61800WOS	30,194.10

« Gear Reduction Hand Wind recommended where net head exceeds 4 metres

OPTIONS

Description	Code	Price
For most height extensions, please contact our office		
Gear reduction for hand wind «	CGE000	4,006.20
Gate open indicator	CGE001	P.O.A
Mast stabilizer bracket, each	CGE002	197.40
Headwall mounting bracket, each	CGE003	285.30
Non Standard Spigots	CGE004	P.O.A

CHANNEL GATES

6 METRE HYDRAULIC HIGH HEAD

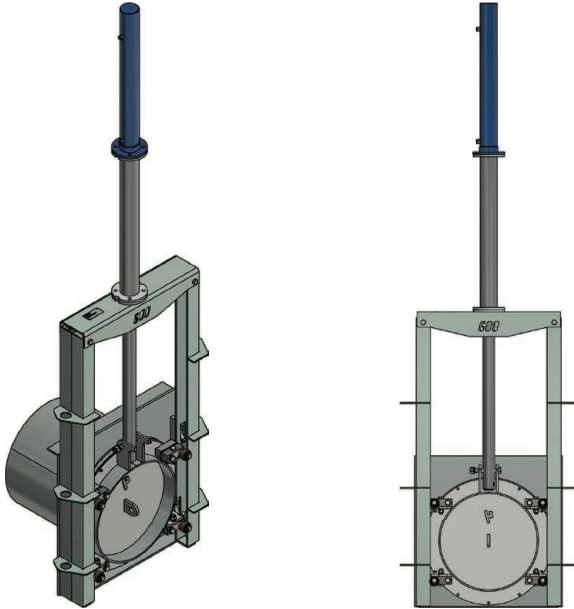

STANDARD FEATURES

- Top Lock
- A large diameter adjustable roller sintered bronze bearing
- Bottom Lock
- Two large diameter rollers with sintered bronze bearings
- Axle Rollers
- Large diameter rollers with sintered bronze bearings
- Door Guide
- Cam adjusted phosphor bronze rollers
- Hydraulic
- Heavy duty, industrial, flange mounted

6 Metre High Head Application On and Off Seating Duty

Size (mm)	Spigot Length (mm) x thickness (mm)	Spigot Centre to Handwheel (mm)	Pipe Centre to Base (mm)	Overall Width (mm)	Std Gate Weight (kg)	Grout In Spigot Code	Weld on Spigot Code	Price
450	450 x 8	1742	356	820	346	G6450HGIS	G6450HWOS	10,478.10
500	450 x 8	1742	356	820	349	G6500HGIS	G6500HWOS	11,755.40
600	450 x 8	2017	406	920	412	G6600HGIS	G6600HWOS	12,995.60
750	450 x 8	2414	481	1070	501	G6750HGIS	G6750HWOS	15,317.00
900	450 x 8	2820	556	1220	654	G6900HGIS	G6900HWOS	15,862.90
1050	450 x 8	3437	631	1370	848	G61050HGIS	G61050HWOS	19,106.50
1200	450 x 8	3745	706	1520	969	G61200HGIS	G61200HWOS	21,025.10
1350	450 x 8	4149	781	1670	1144	G61350HGIS	G61350HWOS	23,547.90
1500	450 x 8	4464	856	1890	1329	G61500HGIS	G61500HWOS	30,003.30
1650	450 x 8	4961	931	2050	1819	G61650HGIS	G61650HWOS	32,812.30
1800	450 x 8	5331	1025	2190	2079	G61800HGIS	G61800HWOS	38,499.20

OPTIONS

Description	Code	Price
For mast height extensions, please contact our office		
Gate open indicator	CGE001	P.O.A
Mast stabilizer bracket, each	CGE002	197.40
Headwall mounting bracket, each	CGE003	285.30
Non Standard Spigots	CGE004	P.O.A

CHANNEL GATES

6 METRE GENERAL ASSEMBLY

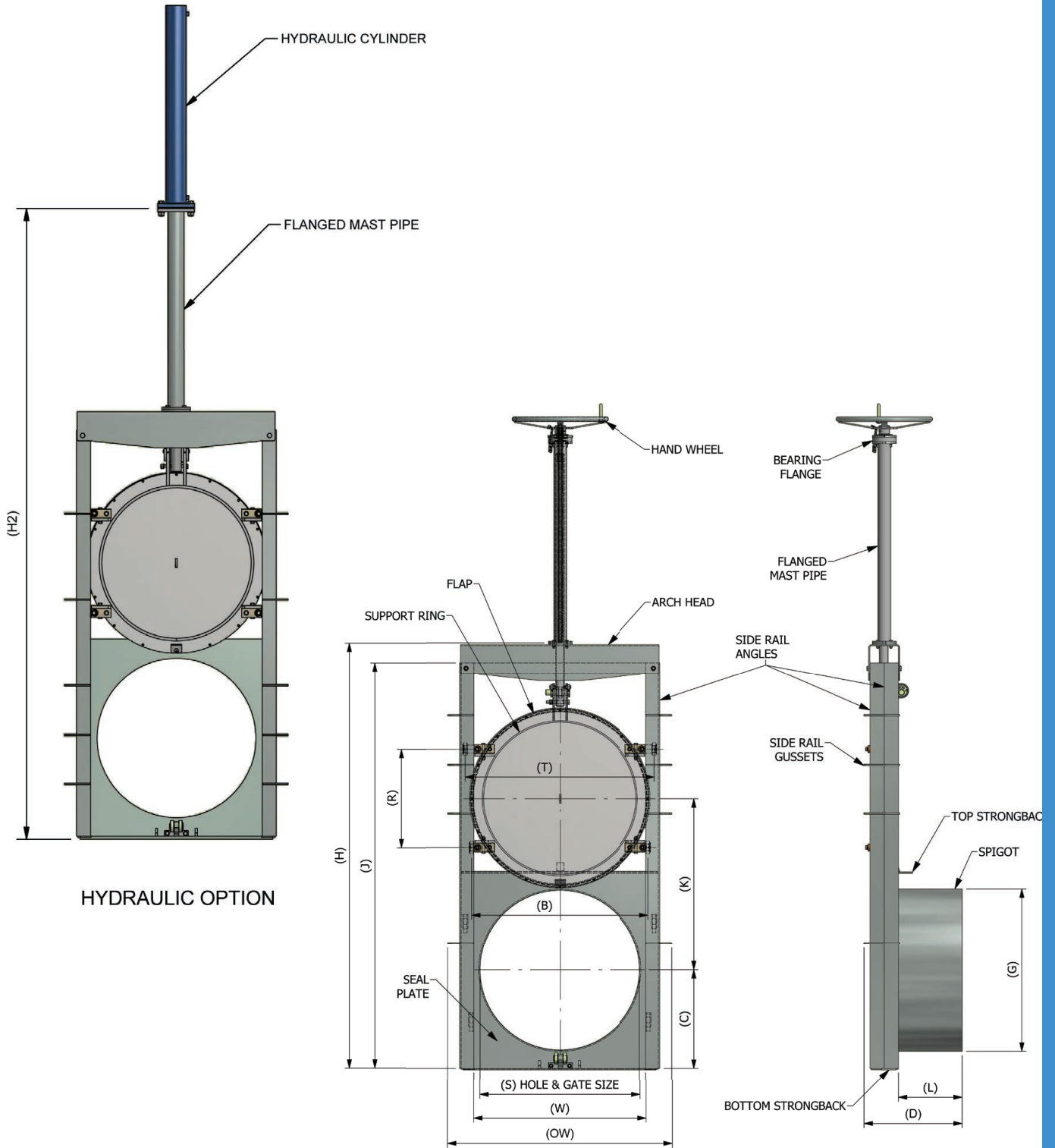

CHANNEL GATES

6 METRE SPECIFICATIONS

GATE SIZE (S)
450
500
600
750
900
1050
1200
1350
1500
1650
1800

HW to SPIGOT CTR (GB)	
450	1916
500	1916
600	2170
750	2580
900	2982
1050	3453
1200	3915
1350	4319
1500	4721
1650	5127
1800	5577

GATE SIZE (S)	BASE TO C/L HOLE (C)	STROKE TO FULLY OPEN (K)	SIDE RAIL LENGTH (J)	WIDTH BETWEEN SIDE RAILS (W)	AXLE CEN-TRES (R)	TOP ROLLER APART (T)	BOTTOM ROLLER APART (B)	SPIGOT DIA. O.D. GROUT (G)	SPIGOT DIA. I.D. WELD (G)	SPIGOT LENGTH (L)	GUSSETS PER SIDE	HEIGHT (H)	OVERALL WIDTH	DEPTH (D)
450	345	535	1330	518	360	608	543	406	450	450	4	1384	830	652
500	345	535	1330	518	360	608	543	484	500	450	4	1380	830	654
600	395	635	1530	618	414	708	643	560	600	450	4	1581	930	654
750	445	785	1839	768	500	858	793	710	750	450	4	1921	1072	658
900	545	935	2159	918	520	1008	943	865	900	450	4	2246	1224	660
1050	620	1085	2525	1068	588	1158	1093	1016	1050	450	4	2641	1438	691
1200	695	1235	2870	1218	700	1340	1250	1150	1200	450	4	3021	1588	692
1350	770	1385	3165	1368	773	1490	1400	1300	1350	450	4	3352	1738	696
1500	845	1535	3478	1518	838	1640	1550	1474	1500	450	5	3703	1888	701
1650	920	1685	3765	1668	960	1730	1700	1626	1650	450	5	4001	2038	701
1800	995	1835	4114	1818	1000	1940	1850	1778	1800	450	5	4386	2188	703

CHANNEL GATES

6 METRE GENERAL ASSEMBLY

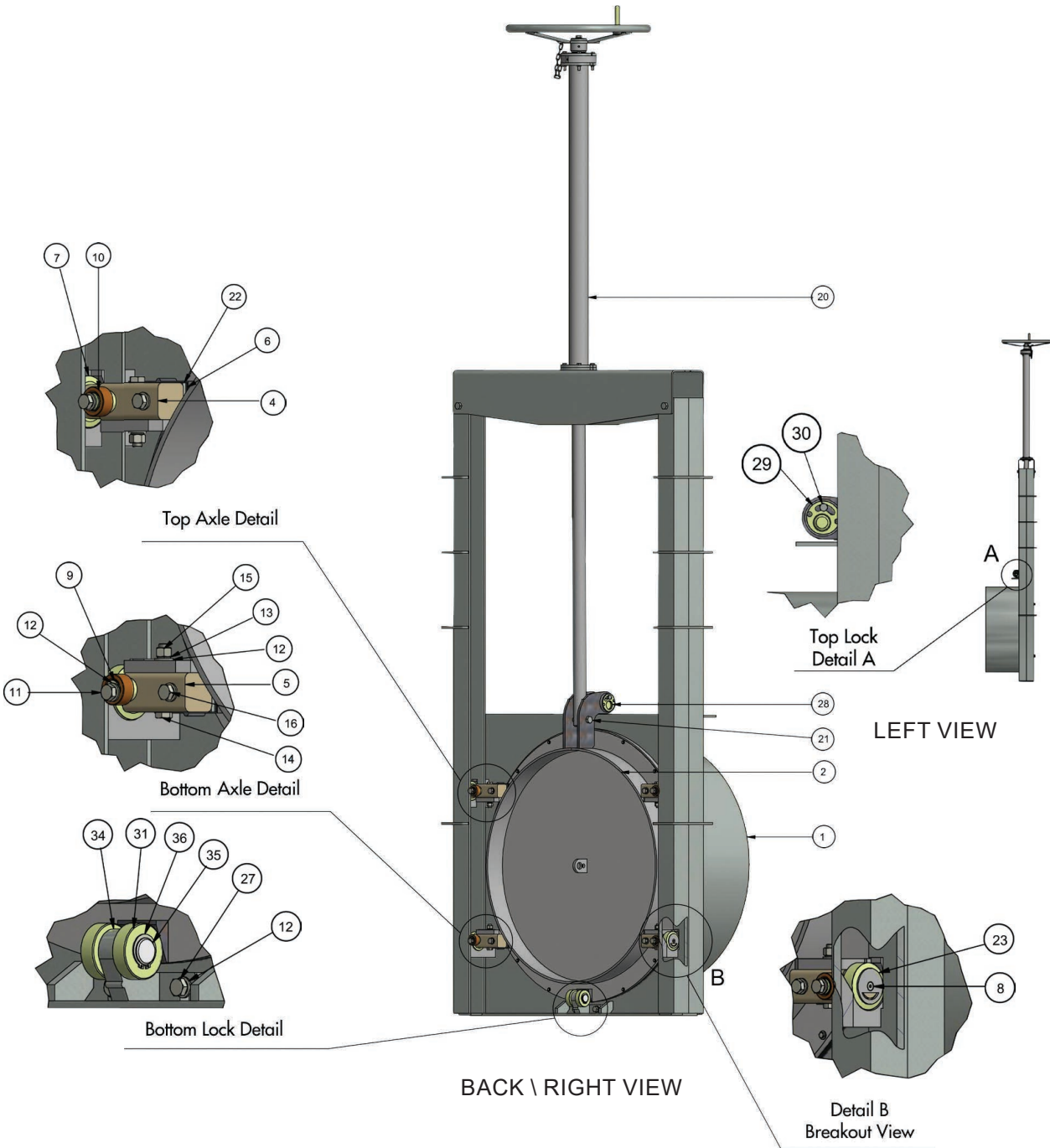

CHANNEL GATES

6 METRE GENERAL ASSEMBLY

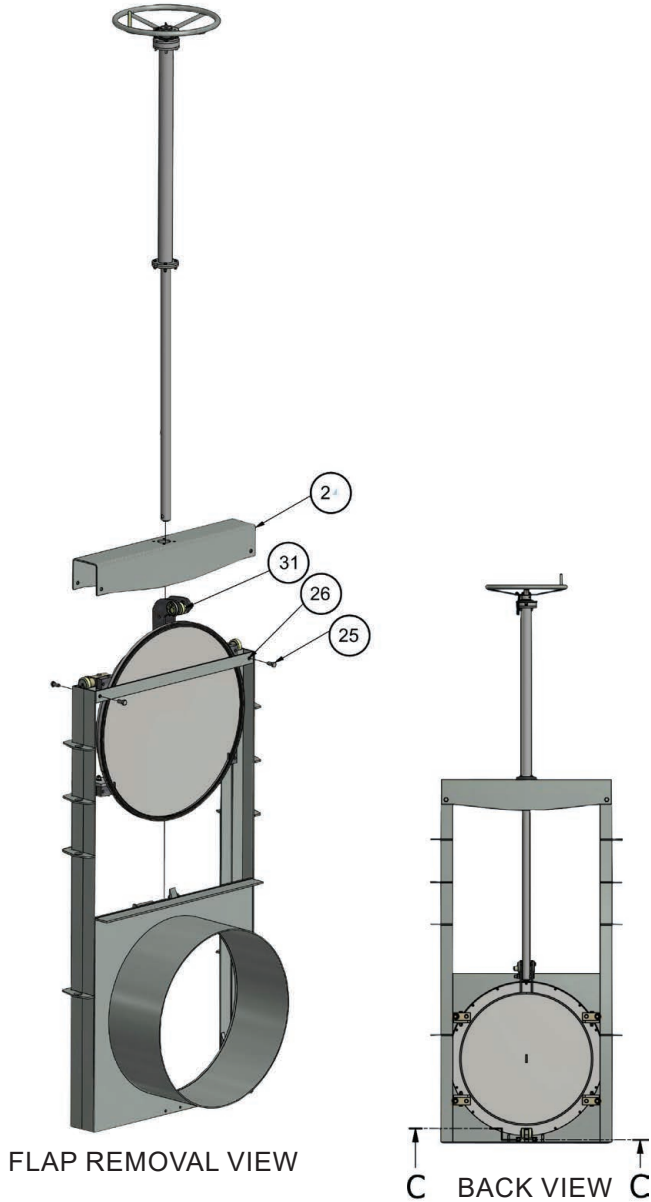

Item	Qty	Description
1	1	Body Kit Galv
2	1	Flap Kit Galv
3	1	Flap Seal C/W Ring And Rubber
4	2	Long Axle Z/P
5	2	Short Axle Z/P
6	8	AXLE SHIM 2mm GALV
7	4	Axle Roller Bushed Z/P
8	4	Retainer Washer Bolt C/Sunk Head S/S 316
9	4	Cam Side Guide Roller Z/P
10	4	Guide Roller Bronze
11	4	Axle Cam Bolt S/S
12	14	Washer Flat S/S 316
13	14	Washer Spring S/S 316
14	4	Axle Cross Bolt S/S 316
15	4	Axle Cross Bolt Nut
16	4	Axle Bolt S/S 316
17	16	Seal Bolt S/S 316
18	16	Seal Bolt Washer S/S 316
19	16	Flap Seal Spacer
20	1	Mast Kit
21	1	Push Pipe Clevis Bolt
22	4	Axle Shim 8mm Galv
23	4	Axle Retaining Washer
24	1	Arch Head
25	4	Arch Head Bolt Assembly Galv
26	4	Arch Head Spring Washer

Channel Gate Size Dependent Parts		
Item	Qty	Description
27	2	Bottom Lock Bolt S/S 316
28	1	Top Lock Cam Pin Z/P
29	1	Top Lock Cam Disc Z/P
30	2	Top Lock Cam Bolt Assembly Galv
31	3	Top & Bottom Lock Roller
32	1	Bottom Lock Shim 4mm Galv
33	2	Bottom Lock Shim 2mm Galv
34	1	Bottom Lock Welded
35	1	Bottom Lock Pin
36	2	Circlip Bottom Lock Roller

Hydraulic Option		
Item	Qty	Description
37	1	Hydraulic Cylinder
38	1	Hydraulic Mast Pipe Outer
39	1	Hydraulic Push Pipe Inner

CHANNEL GATES

6 METRE MAST KIT

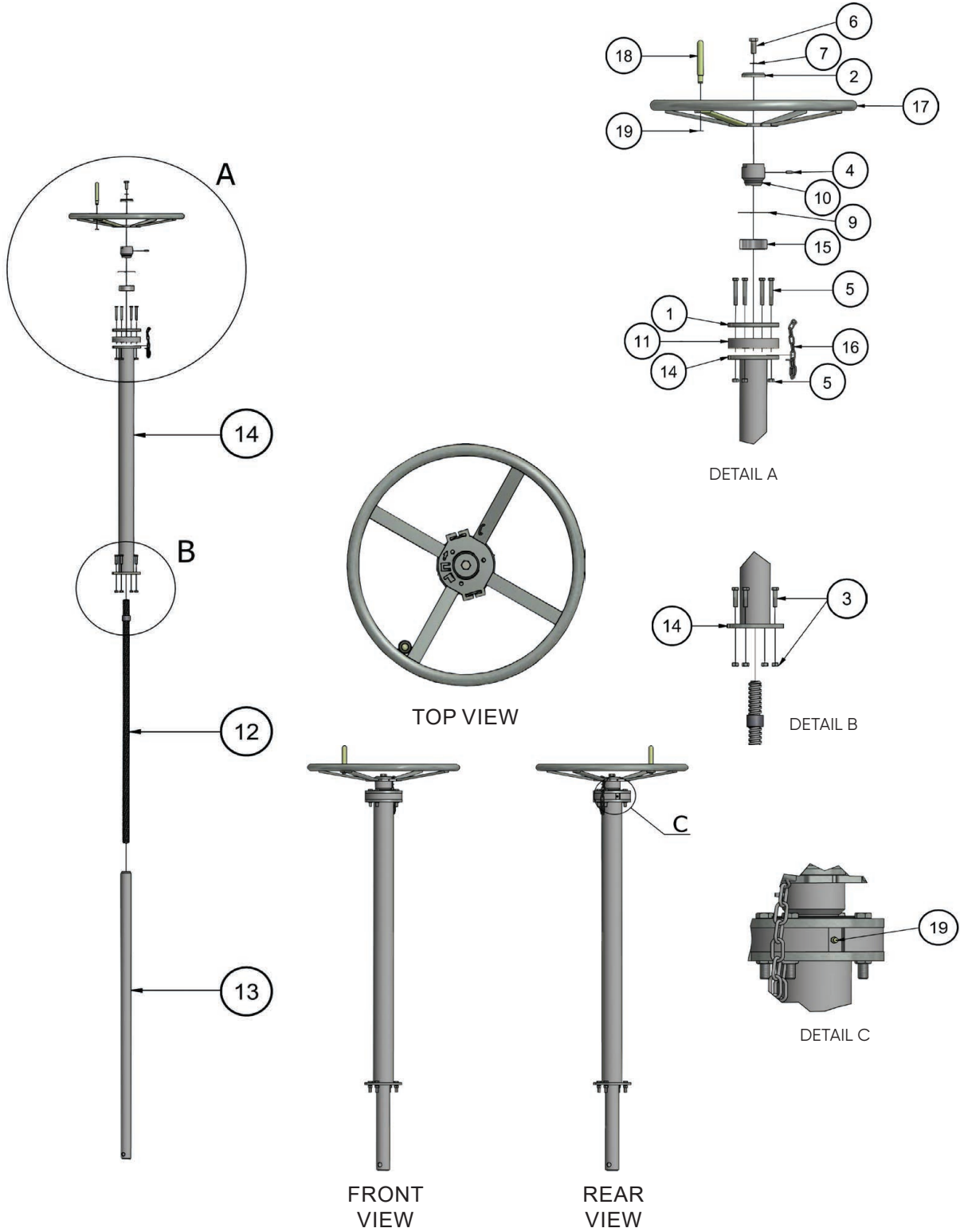

CHANNEL GATES

6 METRE HYDRAULIC OPTION

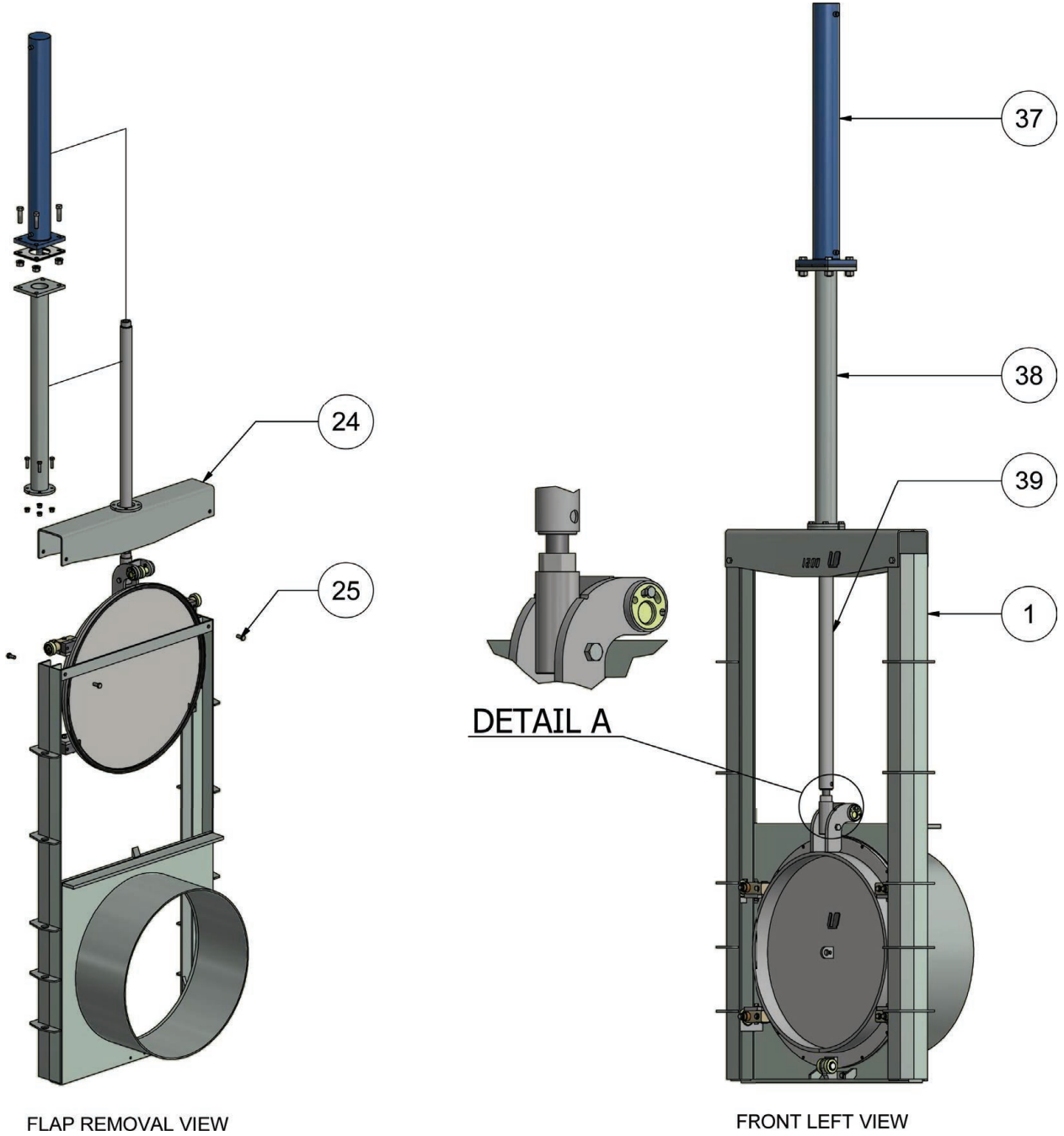

FLAP REMOVAL VIEW

FRONT LEFT VIEW

CHANNEL GATES

6 METRE HYDRAULIC MAST OPTION

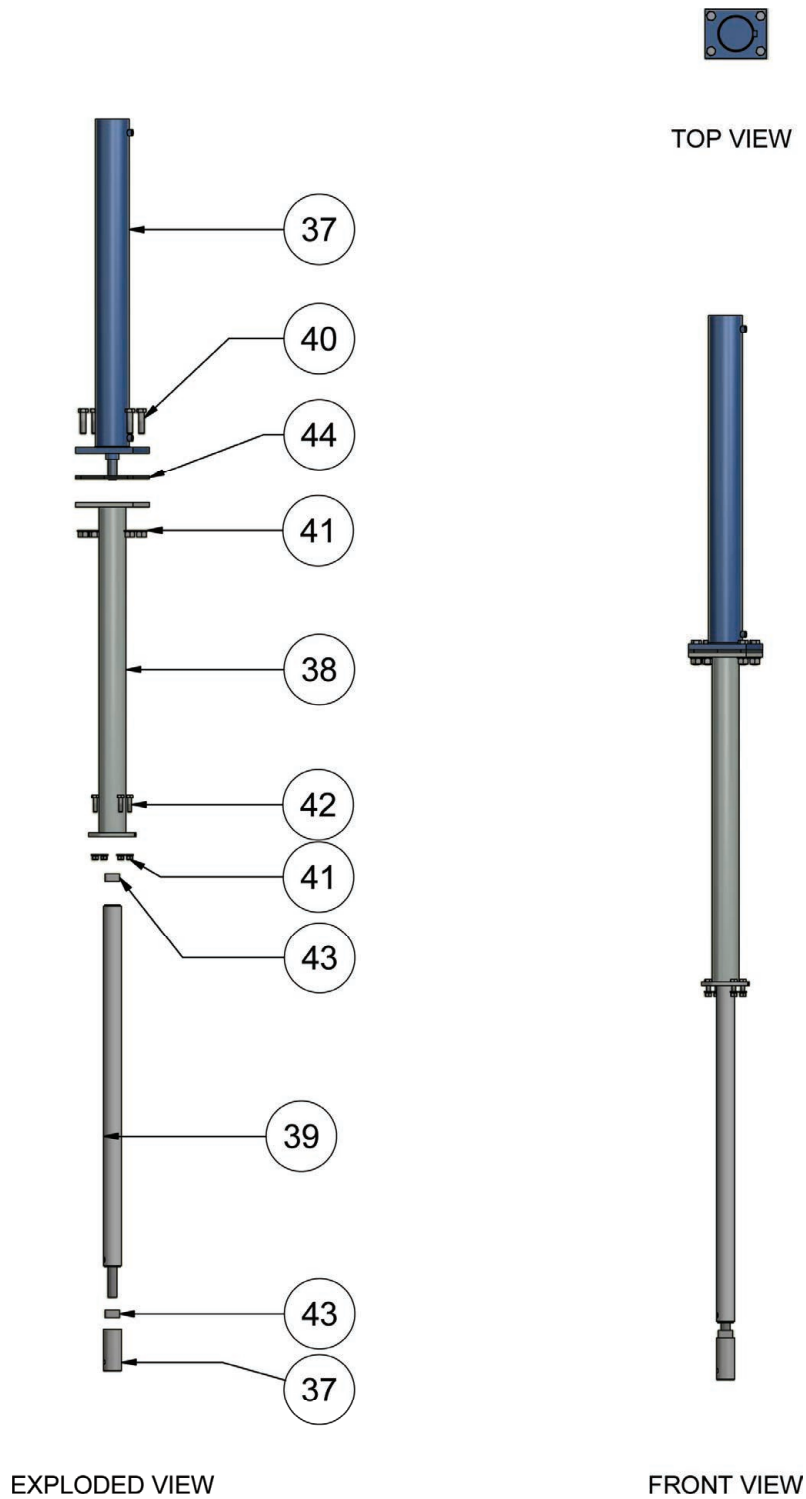

CHANNEL GATES

6 METRE GEAR REDUCTION MAST OPTION

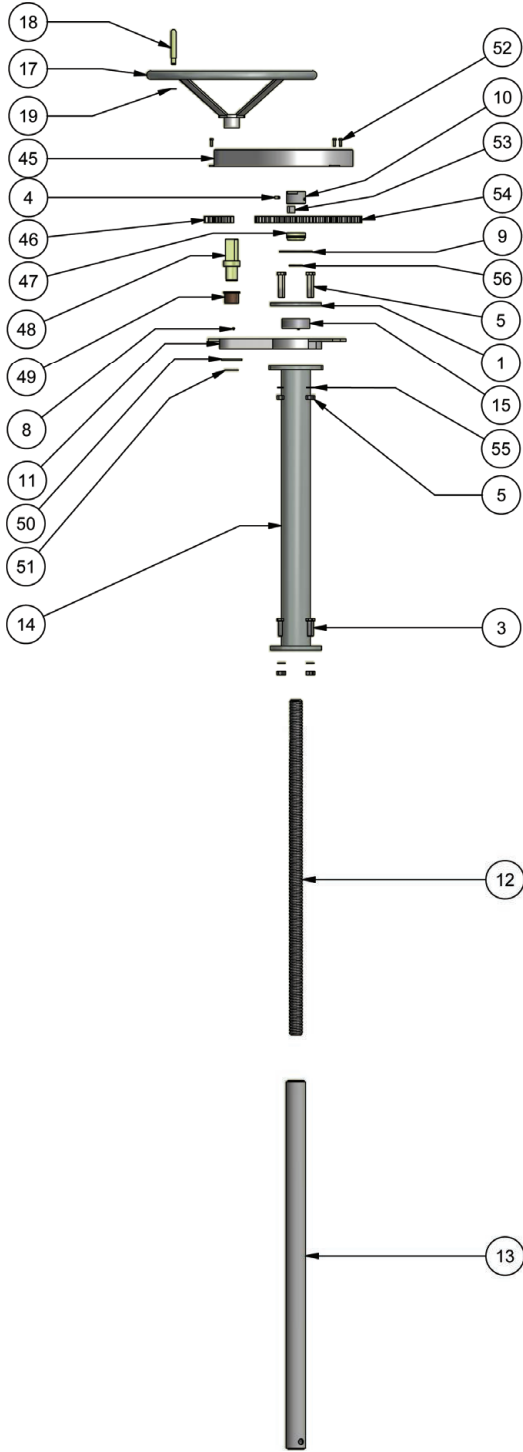

FRONT VIEW

Item	Qty	Description
1	1	Bearing Retainer Flange Gal
2	1	Hand Wheel Washer Gal
3	4	Mast Pipe Bolts
4	1	Lock Screw
5	4	Bearing Housing Bolt & Nut Assy
6	1	Hand Wheel Bolt
7	1	Hand Wheel Bolt Washer
8	1	Grease Nipple
9	1	Poly Seal Ring
10	1	Lock Nut Hand Wheel
11	1	Bearing Housing
12	1	Threaded Shaft
13	1	Mast Push Pipe Inner
14	1	Mast Pipe Outer
15	1	Mast Bearing
16	1	Keeper Chain
17	1	Hand Wheel
18	1	Hand Wheel Handle
19	1	Handle Circlip
37	1	Hydraulic Cylinder with Clevis
38	1	Hydraulic Mast Pipe Outer
39	1	Hydraulic Push Pipe Inner
40	4	Hydraulic Cylinder Bolt & Nut Assembly
41	4	Spring Washer
42	4	Hydraulic Mast Pipe Bolt & Nut Assembly
43	2	Clevis Lock Nut
44	4	Hydraulic Cylinder Packer 6mm Half Piece
45	1	Gearbox Cover
46	1	Small Gear to Suit Gearbox
47	1	Spacer
48	1	Pinion Shaft
49	1	Bush Sinterlite
50	1	Washer Flat Zinc Plated
51	1	Pinion Shaft Circlip
52	3	Gearbox Cover Set Screw
53	1	Threaded Shaft Lock Key
54	1	Large Gear to Suit Gearbox
55	4	Spring Washer
56	1	Circlip

CHANNEL GATES

10 METRE STANDARD HIGH HEAD

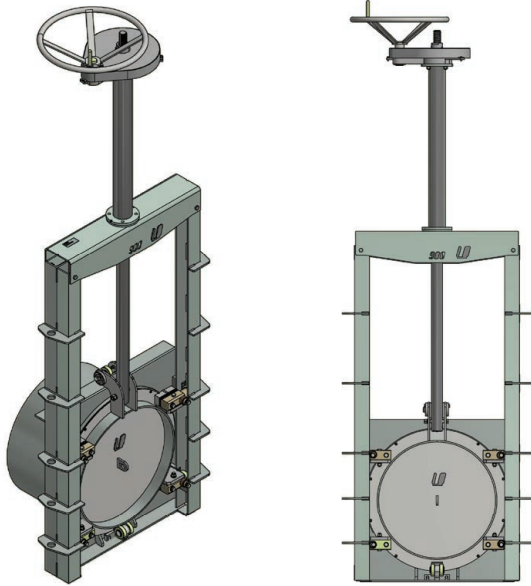

STANDARD FEATURES

- Gear Box
- Top Lock
- A large diameter adjustable roller sintered bronze bearing
- Bottom Lock
- Two large diameter rollers with sintered bronze bearings
- Axle Rollers
- Large diameter rollers with sintered bronze bearings
- Door Guide
- Cam adjusted phosphor bronze rollers

10 Metre High Head Application On and Off Seating Duty

Size (mm)	Spigot Length (mm) x thickness (mm)	Spigot Centre to Handwheel (mm)	Pipe Centre to Base (mm)	Overall Width (mm)	Std Gate Weight (kg)	Grout In Spigot Code	Weld on Spigot Code	Price
900	450 x 12	3287	556	1254	690	G10900GGIS	G10900GWOS	18,921.00
1050	450 x 12	3680	631	1438	881	G101050GGIS	G101050GWOS	20,532.20
1200	450 x 12	4051	706	1572	1103	G101200GGIS	G101200GWOS	23,867.50
1350	450 x 12	4452	781	1750	1244	G101350GGIS	G101350GWOS	25,413.50
1500	450 x 12	4883	856	1880	1443	G101500GGIS	G101500GWOS	32,006.70
1650	450 x 12	5228	931	2080	2400	G101650GGIS	G101650GWOS	41,271.10
1800	450 x 12	5700	1025	2248	2700	G101800GGIS	G101800GWOS	48,410.20

OPTIONS

Description	Code	Price
For most height extensions, please contact our office		
Gate open indicator	CGE00110	POA
Mast stabilizer bracket, each	CGE00210	201.80
Headwall mounting bracket, each	CGE00310	321.70

CHANNEL GATES

10 METRE HYDRAULIC HIGH HEAD

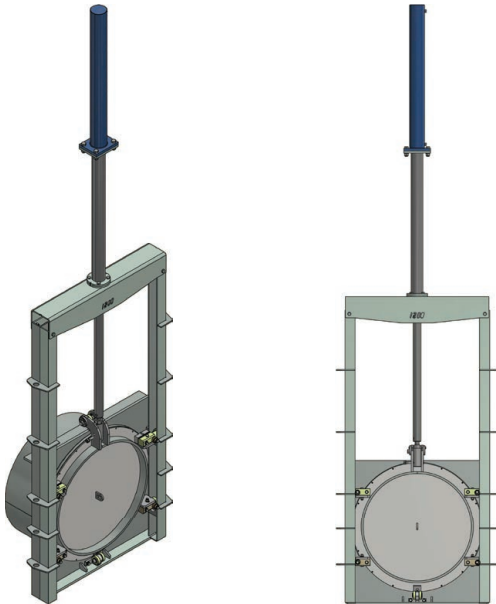

STANDARD FEATURES

- Top Lock
- A large diameter adjustable roller sintered bronze bearing
- Bottom Lock
- Two large diameter rollers with sintered bronze bearings
- Axle Rollers
- Large diameter rollers with sintered bronze bearings
- Door Guide
- Cam adjusted phosphor bronze rollers
- Hydraulic
- Heavy duty, industrial, flange mounted

10 Metre High Head Application On and Off Seating Duty

Size (mm)	Spigot Length (mm) x thickness (mm)	Spigot Centre to Handwheel (mm)	Pipe Centre to Base (mm)	Overall Width (mm)	Std Gate Weight (kg)	Grout In Spigot Code	Weld on Spigot Code	Price
900	450 x 12	2820	556	1254	650	G10900HGIS	G10900HWOS	19,716.00
1050	450 x 12	3337	631	1438	850	G101050HGIS	G101050HWOS	23,441.90
1200	450 x 12	3743	706	1572	1100	G101200HGIS	G101200HWOS	28,996.30
1350	450 x 12	4145	781	1750	1250	G101350HGIS	G101350HWOS	28,885.00
1500	450 x 12	4460	856	1880	1525	G101500HGIS	G101500HWOS	39,437.30
1650	450 x 12	4965	931	2080	2400	G101650HGIS	G101650HWOS	54,102.40
1800	450 x 16	5355	1025	2248	2700	G101800HGIS	G101800HWOS	57,446.70

OPTIONS

Description	Code	Price
For mast height extensions, please contact our office		
Gate open indicator	CGE00110	POA
Mast stabilizer bracket, each	CGE00210	201.80
Headwall mounting bracket, each	CGE00310	321.70

CHANNEL GATES

10 METRE SPECIFICATIONS

GATE SIZE (S)
900
1050
1200
1350
1500
1650
1800

HW to SPIGOT CTR (GB)	
900	3288
1050	3542
1200	4059
1350	4465
1500	4847

GATE SIZE (S)	BASE TO C/L HOLE (C)	STROKE TO FULLY OPEN (K)	SIDE RAIL LENGTH (J)	WIDTH BETWEEN SIDE RAILS (W)	AXLE CEN- TRES (R)	TOP ROLL- ER APART (T)	BOTTOM ROLLER APART (B)	SPIGOT DIA. O.D WELD GROUT (G)	SPIGOT DIA. I.D WELD (G)	SPIGOT LENGTH (L)	GUSSETS PER SIDE	HEIGHT (H)	OVERALL WIDTH	DEPTH (D)
900	545	935	2159	918	615	1008	943	865	900	450	5	2388	1290	
1050	620	1085	2525	1068	588	1158	1093	1016	1050	450	5	2729	1438	696
1200	695	1235	2870	1218	700	1340	1250	1150	1200	450	5	3036	1588	701
1350	770	1385	3165	1368	773	1490	1400	1300	1350	450	5	3370	1738	703
1500	845	1535	3478	1518	838	1640	1550	1474	1500	450	6	3726	1888	703
1650	920	1685	3765	1668	960	1730	1700	1626	1650	450	6	4048	2088	739
1800	995	1835	4114	1818	1000	1940	1850	1778	1800	450	6	4373	2238	739

CHANNEL GATES

10 METRE GENERAL ASSEMBLY

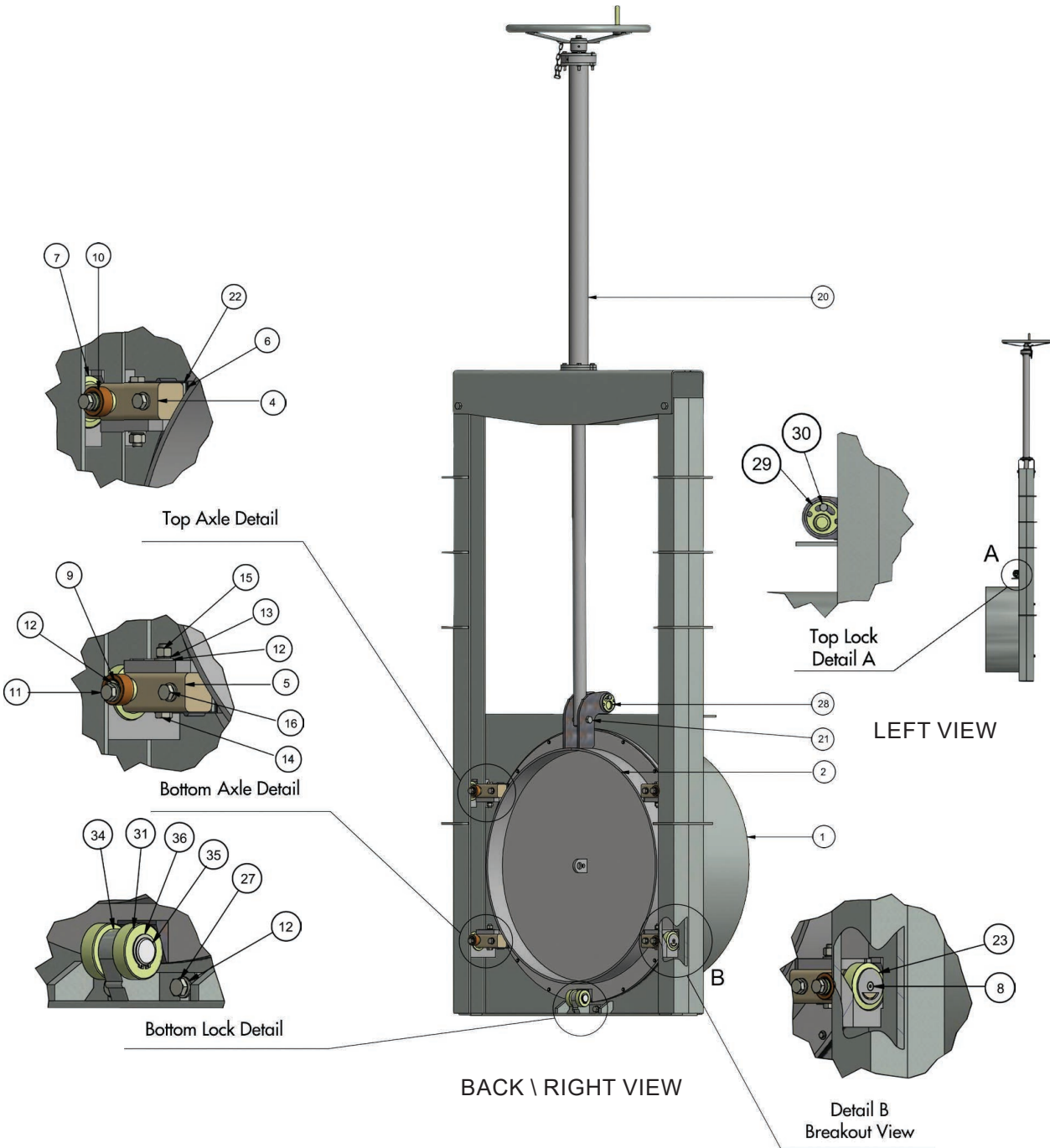

CHANNEL GATES

10 METRE GENERAL ASSEMBLY

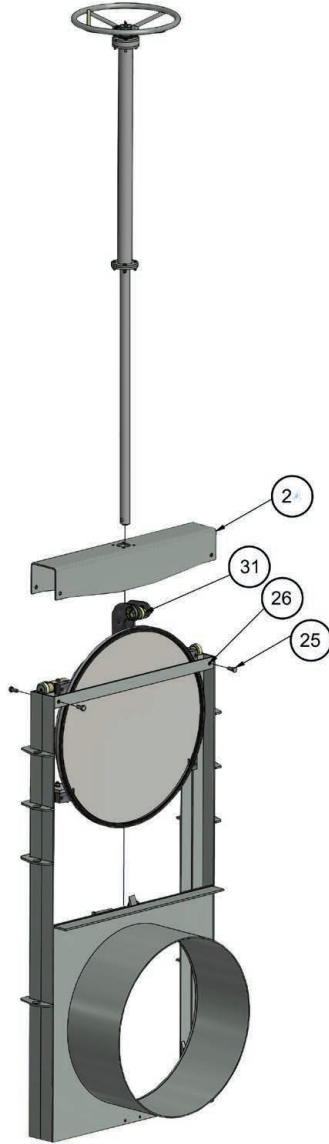

FLAP REMOVAL VIEW

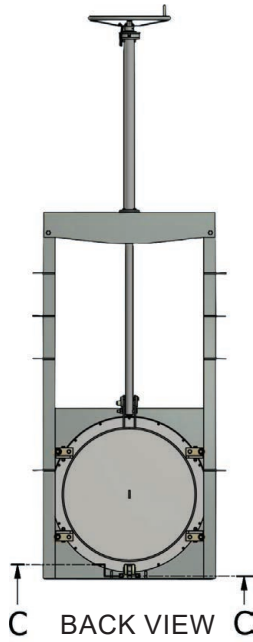

BACK VIEW C C

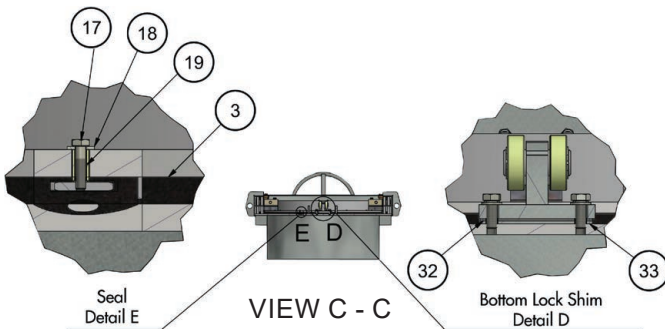

Item	Qty	Description
1	1	Body Kit Galv
2	1	Flap Kit Galv
3	1	Flap Seal C/W Ring And Rubber
4	2	Long Axle Z/P
5	2	Short Axle Z/P
6	8	AXLE SHIM 2mm GALV
7	4	Axle Roller Bushed Z/P
8	4	Retainer Washer Bolt C/Sunk Head S/S 316
9	4	Cam Side Guide Roller Z/P
10	4	Guide Roller Bronze
11	4	Axle Cam Bolt S/S
12	14	Washer Flat S/S 316
13	14	Washer Spring S/S 316
14	4	Axle Cross Bolt S/S 316
15	4	Axle Cross Bolt Nut
16	4	Axle Bolt S/S 316
17	16	Seal Bolt S/S 316
18	16	Seal Bolt Washer S/S 316
19	16	Flap Seal Spacer
20	1	Mast Kit
21	1	Push Pipe Clevis Bolt
22	4	Axle Shim 8mm Galv
23	4	Axle Retaining Washer
24	1	Arch Head
25	4	Arch Head Bolt Assembly Galv
26	4	Arch Head Spring Washer

Channel Gate Size Dependent Parts		
Item	Qty	Description
27	2	Bottom Lock Bolt S/S 316
28	1	Top Lock Cam Pin Z/P
29	1	Top Lock Cam Disc Z/P
30	2	Top Lock Cam Bolt Assembly Galv
31	3	Top & Bottom Lock Roller
32	1	Bottom Lock Shim 4mm Galv
33	2	Bottom Lock Shim 2mm Galv
34	1	Bottom Lock Welded
35	1	Bottom Lock Pin
36	2	Circlip Bottom Lock Roller

Hydraulic Option		
Item	Qty	Description
37	1	Hydraulic Cylinder
38	1	Hydraulic Mast Pipe Outer
39	1	Hydraulic Push Pipe Inner

CHANNEL GATES

10 METRE MAST KIT

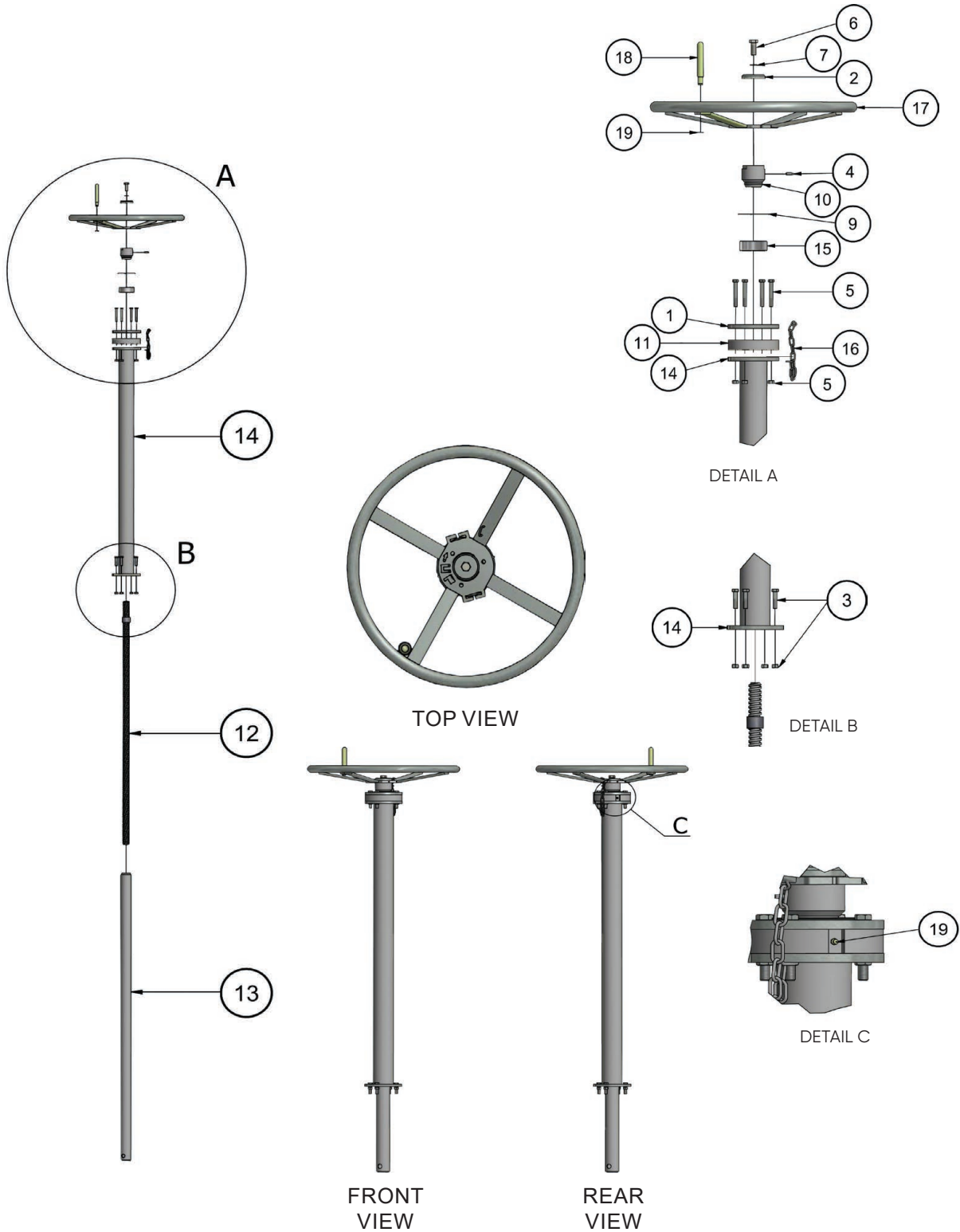

CHANNEL GATES

10 METRE HYDRAULIC OPTION

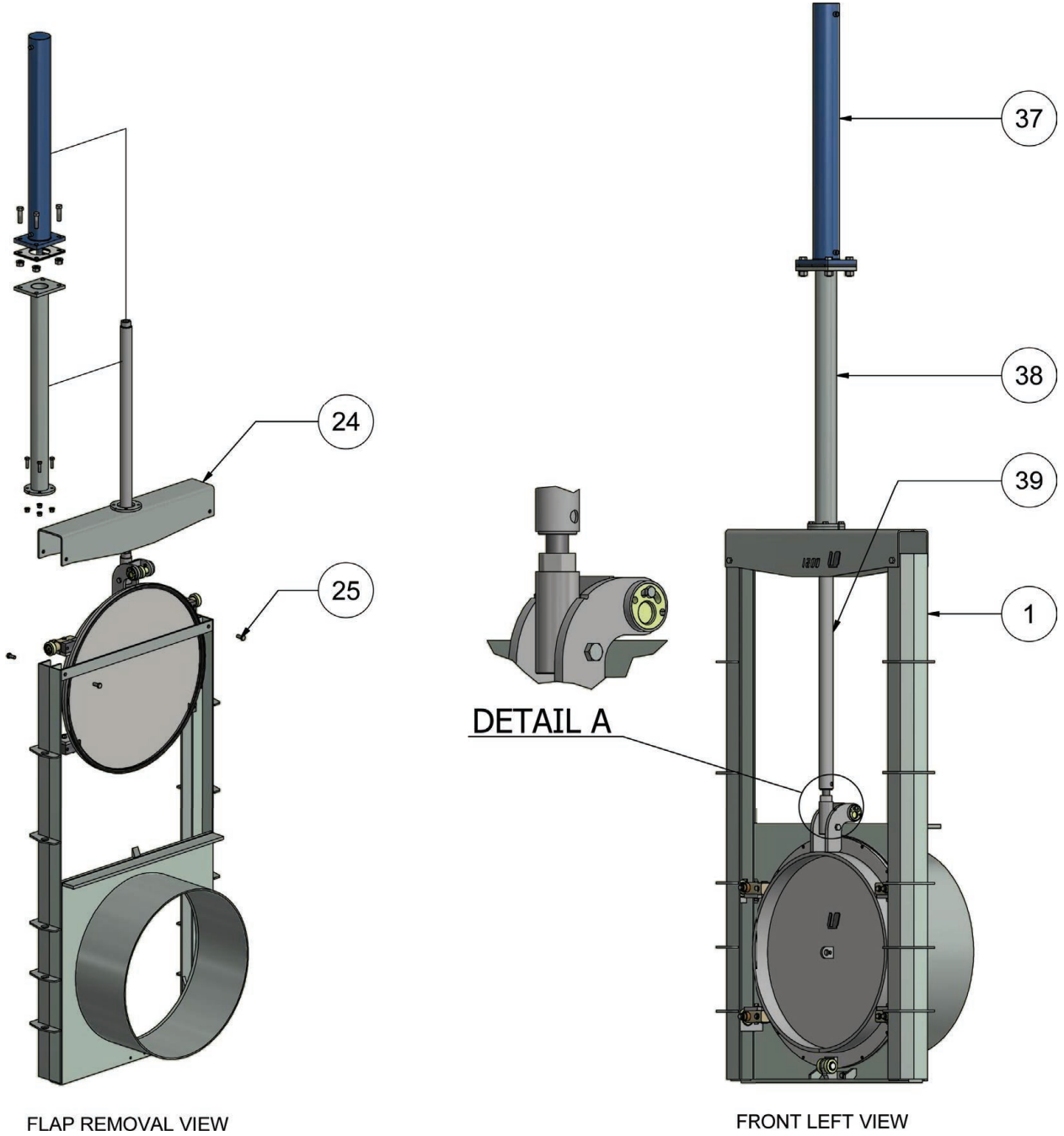

FLAP REMOVAL VIEW

FRONT LEFT VIEW

CHANNEL GATES

10 METRE HYDRAULIC MAST OPTION

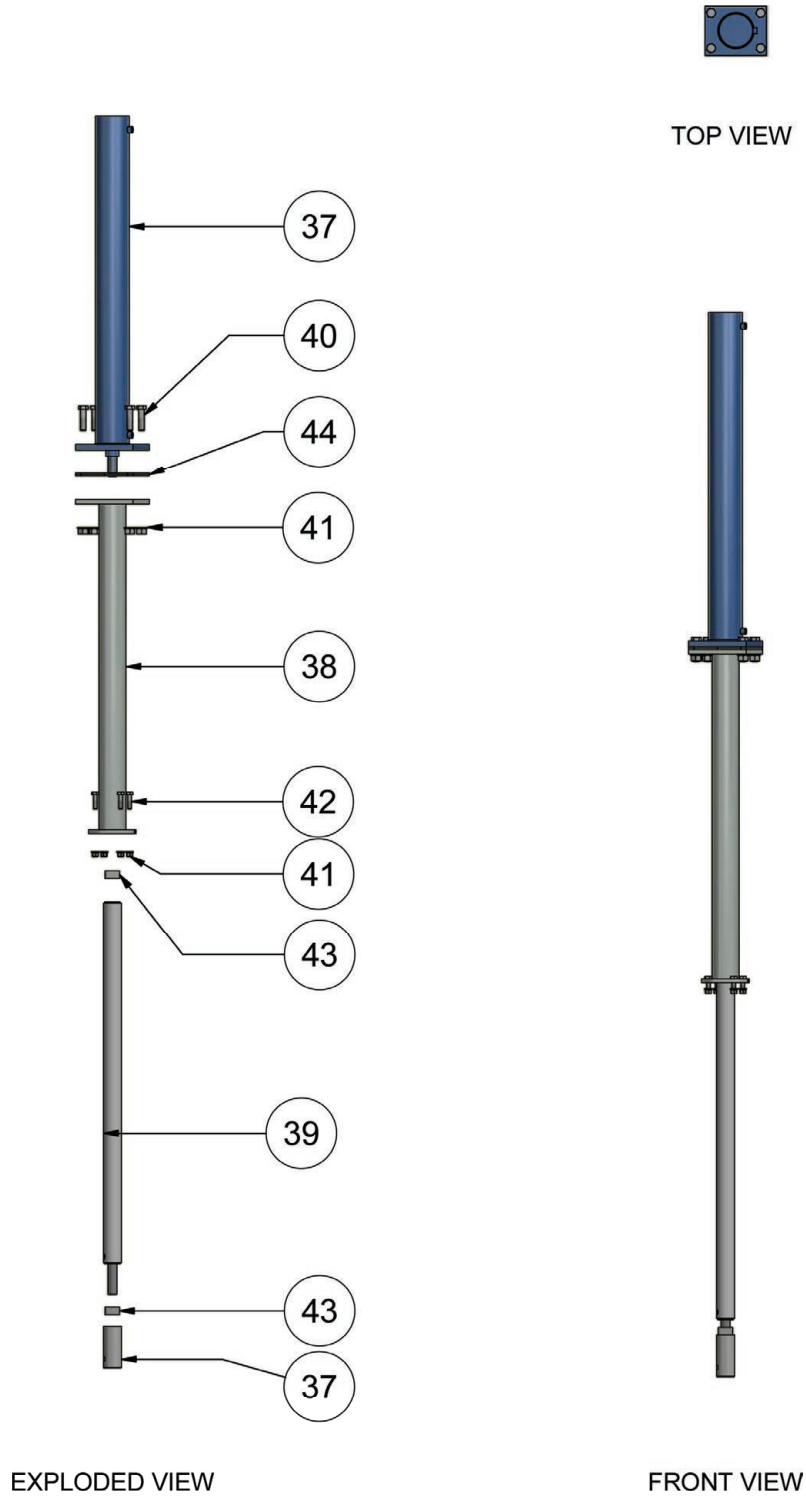

CHANNEL GATES

10 METRE GEAR REDUCTION MAST OPTION

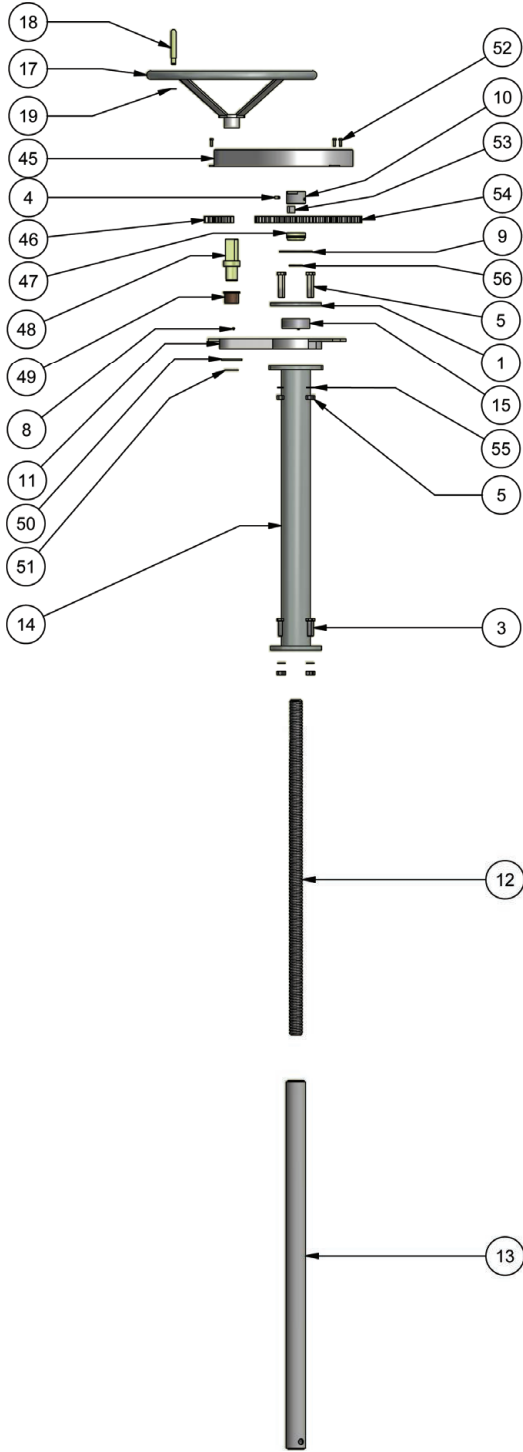

FRONT VIEW

Item	Qty	Description
1	1	Bearing Retainer Flange Gal
2	1	Hand Wheel Washer Gal
3	4	Mast Pipe Bolts
4	1	Lock Screw
5	4	Bearing Housing Bolt & Nut Assy
6	1	Hand Wheel Bolt
7	1	Hand Wheel Bolt Washer
8	1	Grease Nipple
9	1	Poly Seal Ring
10	1	Lock Nut Hand Wheel
11	1	Bearing Housing
12	1	Threaded Shaft
13	1	Mast Push Pipe Inner
14	1	Mast Pipe Outer
15	1	Mast Bearing
16	1	Keeper Chain
17	1	Hand Wheel
18	1	Hand Wheel Handle
19	1	Handle Circlip
37	1	Hydraulic Cylinder with Clevis
38	1	Hydraulic Mast Pipe Outer
39	1	Hydraulic Push Pipe Inner
40	4	Hydraulic Cylinder Bolt & Nut Assembly
41	4	Spring Washer
42	4	Hydraulic Mast Pipe Bolt & Nut Assembly
43	2	Clevis Lock Nut
44	4	Hydraulic Cylinder Packer 6mm Half Piece
45	1	Gearbox Cover
46	1	Small Gear to Suit Gearbox
47	1	Spacer
48	1	Pinion Shaft
49	1	Bush Sinterlite
50	1	Washer Flat Zinc Plated
51	1	Pinion Shaft Circlip
52	3	Gearbox Cover Set Screw
53	1	Threaded Shaft Lock Key
54	1	Large Gear to Suit Gearbox
55	4	Spring Washer
56	1	Circlip

CHANNEL GATES

INSTRUCTIONS

All parts of the Channel Gate and operating mechanisms must be installed and fitted together so that after final assembly there will be no interference through poor alignment or any stress/twisting of the Channel Gate or mast that would in any way effect its operation.

WELD ON SPIGOT

Weld joint to pipe work can be a Butt, Internal or External fit. Note: Do not Jack or Dog out-of-round Pipe Work or Channel Gate Spigot as the Seal behind the Spigot will become Distorted.

WELDING INTO TANKS

When welding into Tanks, attach the Channel Gate by the Spigot, not the Channel Gate Frame. Any movement in the Tank will cause Stress or Twisting of the Channel Gate and Frame Work.

On larger Channel Gates a single Bracket in the centre of the arch Head or Mast Stabilizer Brackets is all that is needed.

The same care needs to be taken as above in Weld On Spigot instruction No. 1. Do not Jack or Dog out-of-round pipe work.

GROUT ON OR GROUT IN SPIGOTS

Channel Gates fitted with grout on or grout in spigots can be supplied with Optional Mounting Brackets for attaching to head walls or other mounting structures.

Ensure when Fitting or Tightening Mounting Brackets that the Channel Gate is not Twisted or Distorted in any way.

MAST AND MAST EXTENSION:

When fitting Channel Gate Mast or Mast Extension it is important to secure the Mast parallel to the Channel Gate Frame, and ensure that the Inner Push Pipe is free to move through its full travel.

Mast Pipes must not be used to support Walkways and always use Mast Stabiliser Brackets that Bolt, not Weld on to Mast Pipes.

FIELD TEST

After final Installation, Assembly and First Service, the Channel Gate Door should be operated fully both Up and Down three or four times to demonstrate that the Channel Gate is in proper working order and free from any interference or alignment defects.

Now check contact between Door Rubber and Gate Body seal area, ensure there is a uniform impression and adjust to eliminate points of poor contact.

When door side guide rolls are fitted there should not be more than 2mm clearance from Side Rail to Roller per side while ensuring the Door is central to the Side Rails.



CHANNEL GATES

INSTRUCTIONS

OPERATION INSTRUCTIONS

- Channel Gates are operated Manually or with a Hydraulic Cylinder.
- Manual operation is by a Handwheel attached to a Right Hand Thread, Shaft or Nut.
- The word "UP" with an arrow is cut into Handwheel Mounting Flange, indicating direction of rotation to open the Channel Gate Door.
- If a four-to-one two-speed gear reduction has been fitted, the direction arrows are on the gear cover.
- Hydraulic Cylinder operation – refer to installer's instructions.
- In the event that the Handwheel is difficult to operate Do Not Use Force.
- Check for any obstructions that could be Jamming the Door, Axles, Mast Pipe, or Mast Thread or Nut.
- In the event that you are unable to overcome a particular problem, contact the distributor from whom you purchased the Channel Gate.

MAINTENANCE

It is Recommended that Once a Year your Channel Gate be Serviced and Inspected.

- Grease, Mast Bearing located under the Handwheel.
- Grease or Oil Mast Thread and Nut.
- Inspect and Tighten, all Bolts and Nuts.
- Inspect Seal for Cuts or Tears.
- Inspect all Parts for Wear. Axles, Rollers, Pins and So On.
- When the Channel Gate is not in Use or Dry, Open Gate Door to prevent Seal Bind.





Rodney Industries

RODNEY INDUSTRIES

19 Valente Close,
Chermside QLD 4032
Phone: +61 7 3624 0300



Connect with Us



Proudly a division of

Vinidex
by aliaxis