



Rodney Industries

APRIL 2024

IRRIGATORS, HOSES, GUNS & SPRINKLERS



TABLE OF CONTENTS

TABLE OF CONTENTS



RI Travelling Irrigators



Water Winch



Turbo Winch

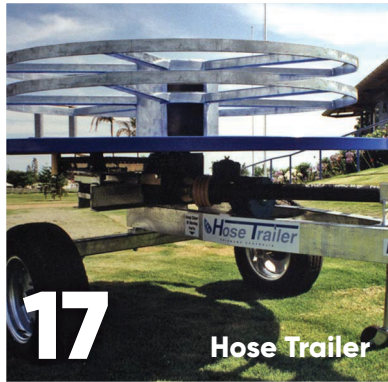

Hose Trailer



Marani Hard Hose Irrigators



Orma Hard Hose Irrigators



Rainspan Booms



Briggs Booms



Marani Spray Booms

TABLE OF CONTENTS

TABLE OF CONTENTS

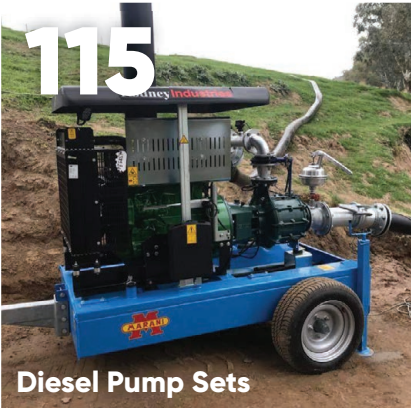

115
Diesel Pump Sets



Centrifugal Pumps
147



153
Digital Irrigation



165
Angus Irrigation Hose



Nelson Big Guns & Sprinklers
168

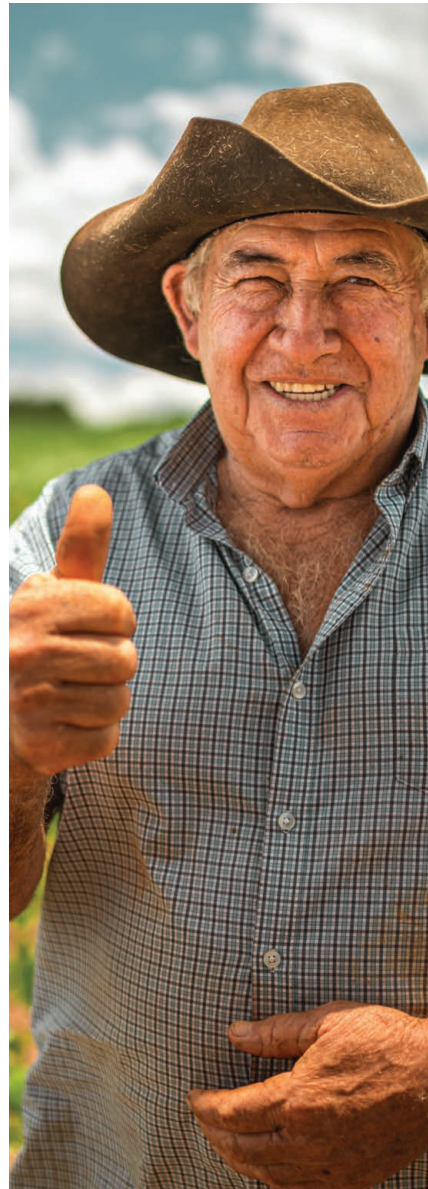

SIME Sprinklers & Guns
173



177
Komet Guns



Sprinkler Accessories
180

THE FULL SERVICE EXPERTS

Whether you purchase one of our Marani Hard Hose Irrigators, Turbine, Piston, Boom or Travelling Irrigators, we understand that it is a big investment and that is why we offer the complete service.

The sales team at Rodney Industries is with you and your dealer throughout the entire process, from finding the best irrigator to suit your requirements both financially and performance wise, right through to stocking all the accessories.

We have the fittings, hose, guns, sprinklers and diesel pump sets for your entire project.

Our trained staff not only complete a comprehensive pre delivery check on all our irrigators prior to despatch, but are also available to assist with the commissioning of your new machine. Once the machine is installed, we continue our service to you with ongoing support, spare parts and all of your after sales service needs.

It is this ongoing product evolution and guaranteed quality systems which drive our team to remain one of the leading suppliers to the irrigation market in Australia.

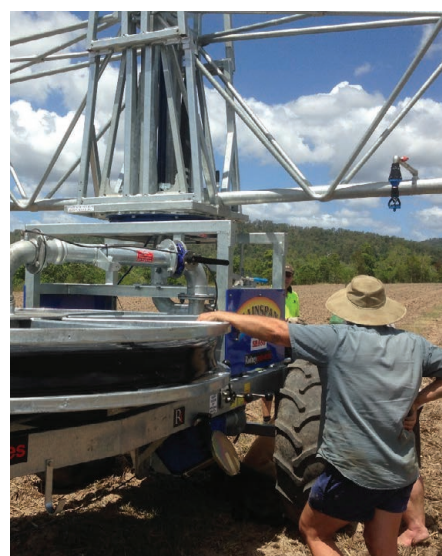
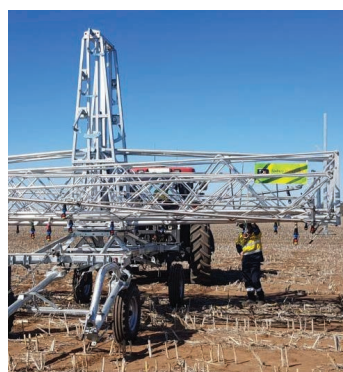

SPORTING FIELDS



Suitable Models

- **RI Range:** RI-10, RI-20, RI-30
- **Orma Hard Hose:** Leader 20, Leader 25, Leader 32, Leader 40, Leader 50, Leader 63
- **Marani Hard Hose:** F010B

PARKS & GARDENS



Suitable Models

- **RI Range:** RI-30
- **Water Winch:** RI-350P
- **Orma Hard Hose:** Leader 20, Leader 25, Leader 32, Leader 40, Leader 50, Leader 63
- **Marani Hard Hose:** F010B

DAIRY FARMS / SMALL CROPS



Suitable Models

- **Water Winch:** RI-350P
- **Turbo Winch:** RI-350T, RI-450T
- **Orma Hard Hose:** Leader 50, Leader 63
- **Marani Hard Hose:** F010B, GT015B

MEDIUM CROPS



Suitable Models

- **Water Winch:** RI-350P
- **Turbo Winch:** RI-350T, RI-450T
- **Marani Hard Hose:** Entire range
- **Rainspan Boom:** SB550
- **Briggs Boom:** R18, R24, R30, R40, R46

LARGE CROPS



Suitable Models

- **Marani Hard Hose:** GT050B, GT060B, GT070B, GTS080B, GTS090C, IT050B, IT060B, IT070B, ITS080B, ITS080C, ITS090C, IT100B
- **Rainspan Boom:** SB2000
- **Briggs Boom:** R40, R46, R50/2, R64/2, R76



**REAL PEOPLE
REAL PRODUCTS
REAL SOLUTIONS**

RI RANGE

TRAVELLING IRRIGATORS



THE SMALL BUT MIGHTY

Formally a part of the Southern Cross Range of irrigators, our RI Range consists of 3 smaller sized irrigators the RI 10, RI 20 and RI 30.

These Australian designed and manufactured irrigators boast hot dipped galvanizing to protect the machines from the harsh elements as well as increase their durability. They are simple to operate and have the power to handle all conditions.

Other features include:

- Self – propelled
- Auto stop
- Integral hose reel (RI-20/30 models)
- Adjustable speed
- Positive drive via winch cable & anchor

THE RANGE



RI 10



RI 20



RI 30

RI RANGE TRAVELLING IRRIGATORS

RI 10

MACHINE FEATURES

- Water-jet powered rotary driving arms acting through high quality worm reduction drive to cable winch.
- Heavy duty welded steel chassis all hot dip galvanized.



BASIC

BASIC IRRIGATOR	Code	Price
Without Hose Kit & Sprinkler	RI010	3,558.80

MACHINE DETAILS

Flow Rate:	0.73 to 1.4 litres per second
Operating Pressure Range:	275 to 345 kPa
Travel Distance Per Run:	100 metres
Wetted Width:	32 to 40 metres



COMPLETE

COMPLETE IRRIGATOR	Code	Price
1" x 55m Hose Kit	RI010K	4,437.70

Hose connection to irrigator end only

Nelson F70 Sprinkler with 5.6mm Nozzle

NOZZLE OPTIONS



Nozzle Size	Code	Price
5.6mm	7RN732	16.30
6.4mm	7RN14	16.30
7.2mm	7RN932	16.30
8.0mm	7RN516	16.30

SEAL KITS

DESCRIPTION	Code	Price
Seal Kit to Suit RI10 & RI20	TCAKIT	21.20

RI RANGE TRAVELLING IRRIGATORS

RI 20

MACHINE FEATURES

- Water-jet powered rotary driving arms acting through high quality worm reduction drive to cable winch.
- Heavy duty welded steel chassis all hot dip galvanized.
- Choice of skid or front wheels.

MACHINE DETAILS

Flow Rate:	1.73 to 7.12 litres per second
Operating Pressure Range:	345 to 483 kPa
Travel Distance Per Run:	126 metres
Wetted Width:	44 to 67 metres

BASIC



BASIC IRRIGATOR WITH WHEELS	Code	Price
Without Hose Kit & Sprinkler	RI020W	4,845.80

BASIC



BASIC IRRIGATOR WITH SKID	Code	Price
Without Hose Kit & Sprinkler	RI020S	4,690.30

COMPLETE

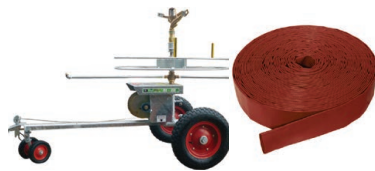

COMPLETE IRRIGATOR WITH WHEELS	Code	Price
11/2" x 67m Hose Kit	RI020KW	6,121.30
Hose connection to irrigator end only		
Nelson F80 Full Circle Sprinkler with 8.7mm Main Nozzle		

COMPLETE



COMPLETE IRRIGATOR WITH SKID	Code	Price
11/2" x 67m Hose Kit	RI020KS	5,953.00
Hose connection to irrigator end only		
Nelson F80 Full Circle Sprinkler with 8.7mm Main Nozzle		

NOZZLE OPTIONS



Nozzle Size	Code	Price
8.7mm	8DRN1132	40.80
9.5mm	8DRN38	43.70
11.1mm	8DRN716	43.70
11.9mm	8DRN1532	47.70
12.7mm	8DRN12	49.10
14.3mm	8DRN916	57.20
15.1mm	8DRN1932	58.50
15.9mm	8DRN58	58.50
17.5mm	8DRN1116	58.50

SEAL KITS

DESCRIPTION	Code	Price
Seal Kit to Suit RI10 & RI20	TCAKIT	21.20

RI RANGE TRAVELLING IRRIGATORS

RI 30

MACHINE FEATURES

- Powerful piston type water motor with lever action drive to large diameter cable winch.
- Heavy duty welded steel chassis all hot dip galvanized.
- Vertical type for easy layout and rewind.

MACHINE DETAILS

Flow Rate:	1.7 to 7.3 litres per second
Operating Pressure Range:	413 to 551 kPa
Travel Distance Per Run:	200 metres
Wetted Width:	46 to 70 metres

BASIC



BASIC IRRIGATOR	Code	Price
With Hose Reel	RI030B	12,072.30

COMPLETE



COMPLETE IRRIGATOR	Code	Price
100m x 2" Angus Hi-Flow Irrigator Hose	RI030X	16,143.80
2" Hose connection on irrigator end only		
Nelson P85 Part Circle Sprinkler with 8.7mm main nozzle		

NOZZLE OPTIONS



Nozzle Size	Code	Price
8.7mm	8DRN1132	40.80
9.5mm	8DRN38	43.70
10.3mm	8DRN1332	43.70
11.1mm	8DRN716	43.70
11.9mm	8DRN1532	47.70
12.7mm	8DRN12	49.10
13.5mm	8DRN1732	57.20
14.3mm	8DRN916	57.20
15.1mm	8DRN1932	58.50
15.9mm	8DRN58	58.50
17.5mm	8DRN1116	58.50



SEAL KITS

DESCRIPTION	Code	Price
Seal Kit to Suit RI30	PCCKIT	293.80

RI RANGE TRAVELLING IRRIGATORS

TYPICAL METHOD OF OPERATION

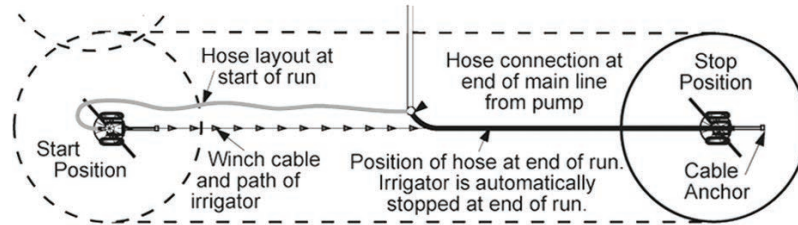

WEIGHTS AND DIMENSIONS

RI 10 ...Mass: 80 kg (including hose)

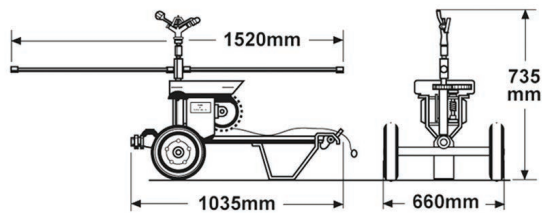

RI 20 ...Mass: 135 kg (including hose)

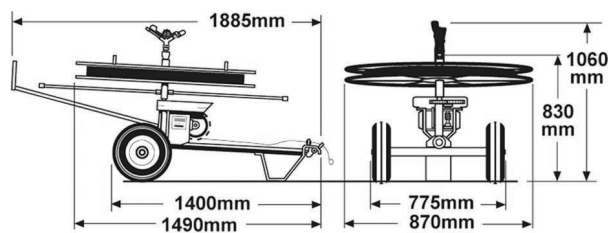

RI 30 ...Mass: 260 kg (including hose)

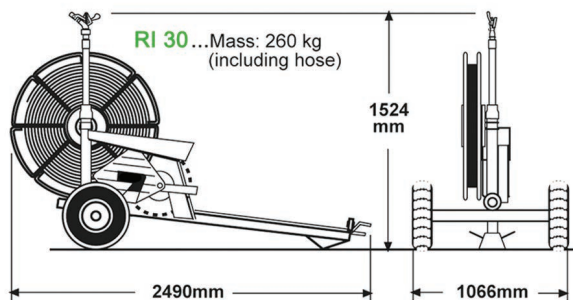

WATER WINCH

TRAVELLING IRRIGATORS



The Rodney Industries' Water Winch is the ideal machine for irrigating sporting fields right through to medium scale crops.

We understand that every irrigation project is different. With our range of Water Winch Travelling Irrigators, you can take our base model and add the options you need – purge kit etc.

There are many other features that allow our Water Winch Travelling Irrigators to stand out from the competitors, here are just a few:

- Australian designed and manufactured
- Piston type water motor
- Positive drive via winch
- Cable and anchor
- Hot dip galvanized
- Self – propelled
- Safe and easy operation
- Auto stop
- Heavy duty design
- P.T.O hose reel
- Adjustable speed
- Spare parts and backup service available

FEATURES

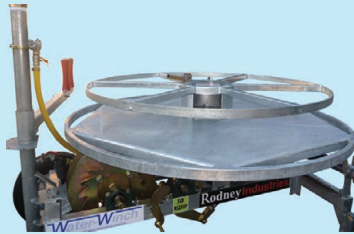

FULLY WELDED HOSE REEL

- Rigid galvanized hose reel.
- Protects drive train from the elements.

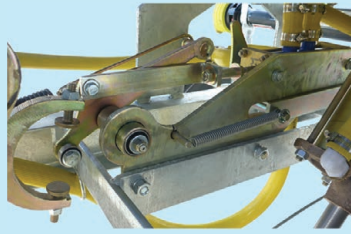

SIMPLE ACTUATING SYSTEM

- Easy adjustment.
- Robust design.
- Low maintenance.



POWERFUL WATER MOTOR

- Large bore double acting cylinder.
- Powerful operation for heavy soil conditions.



REAR WHEEL BRAKES

- Quick and easy to use



DUAL ROCKER ARMS

- Drive unit on top of chassis.
- Easy access for maintenance.



ROLLER BOX

- Telescopic.
- Polyurethane rollers.
- Limits wear on hose.



TOUGH TERRAINS?

The type of terrain is a key factor in determining which irrigator to purchase. Some terrains require a machine to have the extra stability from wider tyres. Perhaps you need to reduce rutting in your crop? Or even soil compaction? That's why with the Rodney Industries' Water Winch, Floatation tyres now come standard!



WHEN PERFORMANCE MATTERS

In the field of large-volume sprinklers, Nelson Big Guns® are recognized the world over as the leader in quality and performance. They are engineered and precision manufactured for heavy-duty reliability and long wear life with minimum maintenance required. Every Nelson Big Gun® is subjected to the toughest inspection testing and quality control standards in the industry.

WATER WINCH

RI 350P



MACHINE DETAILS

Sprinkler:	Nelson SR100 \ Nelson SR150 \ Nelson 200
Hose:	2.5" up to 200m 3" and 3.5" up to 200m 4" up to 150m
Flow Rate:	5.15 to 34.42 litres per second
Operating Pressure Range:	413 to 620 kPa
Travel Distance Per Run:	Up to 400 metres
Wetted Width:	69 to 132 metres
Driving Mechanism:	Double acting cylinder water motor and drive mechanism for reliable services in the heaviest soil conditions.
Construction:	Heavy duty welded steel chassis all hot dip galvanized.
Hose Reel:	Fully welded, galvanized hose reel.

MACHINE FEATURES

- Australian designed and manufactured
- Piston type water motor
- Positive drive via winch
- Cable and anchor
- Hot dip galvanized
- Self – propelled
- Safe and easy operation
- Auto stop
- Heavy duty design
- P.T.O hose reel
- Adjustable speed
- Spare parts and backup service available

Size	Code	Price
------	------	-------

BASE IRRIGATOR

- Hose reel with 410 m x 7 mm wire rope
- Flotation tyres
- Brake Kit
- PTO Shaft
- Galvanized Chassis

25011 28,797.70

Machine Options	Code	Price
-----------------	------	-------

Purge kit (Model MEC1000 Vacuum Pump) 76099A 4,362.00

Irrigation Gun Options	Code	Price
------------------------	------	-------

Nelson Big Gun SR150 Complete SR150K 4,974.40

Nelson Big Gun SR200 Complete SR200K 7,721.90

Connection Options	Code	Price
--------------------	------	-------

Ring Type Coupler 2½" x 4" 9996 163.60

Ring Type Coupler 3" x 4" 9992 193.40

Ring Type Coupler 3½" x 4" 9997 214.50

Ring Type Coupler 4" x 4" 9998 189.10

Seal Kits	Code	Price
-----------	------	-------

Seal Kit to suit Actuvative Valve 76621 65.10

Seal Kit to Ssuit Ram Water Winch 76719 39.60

Please note: Sprinkler and Hose is optional and is not included in the base kit.

WATER WINCH

WEIGHTS & DIMENSIONS

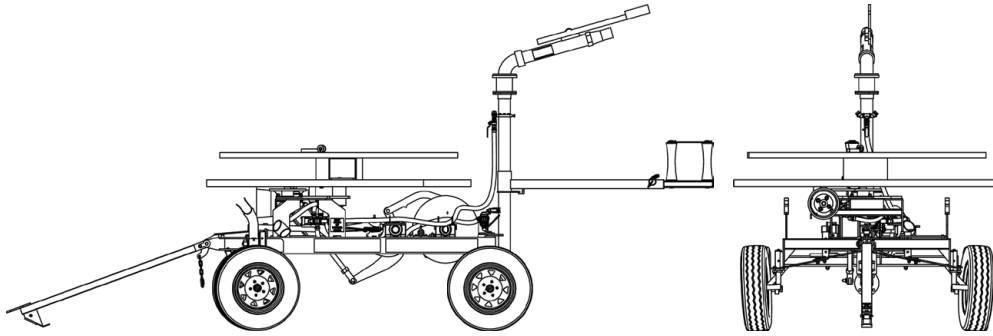

Ground Clearance (mm)	Length (mm)	Width (mm)	Height (mm)	Weight (kgs)
250	2450	1830	1800	875

Weight does not include gun or hose.

Please note weights and dimensions are to be used as a guide only. Contact Rodney Industries or your local distributor for more detailed specifications.



TURBO WINCH

TRAVELLING IRRIGATORS



The Rodney Industries' Turbo Winch is the ideal machine for irrigating sporting fields right through to medium scale crops.

There are many other features that allow our Turbo Winch Travelling Irrigators to stand out from the competitors, here are just a few:



- Australian designed and manufactured
- Radial inflow turbine
- Fully galvanized chassis
- Travel shut off mechanism
- Industrial type 4 speed gearbox
- Four wheel stance
- Safe and easy operation
- Robust construction
- Spare parts and backup service available

FEATURES

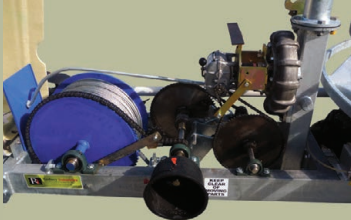

RADIAL INFLOW TURBINE

- Delivers high torque at low RPMs.
- Efficient when under load.
- Full power available when most needed - near end of run.



INDUSTRIAL TYPE 4-SPEED GEARBOX

- Speed of travel to suit any crop can be easily selected.
- Extremely flexible speed range.



HOSE REEL DRIVE RELEASE

- Manually disengage drive for easy hose layout.

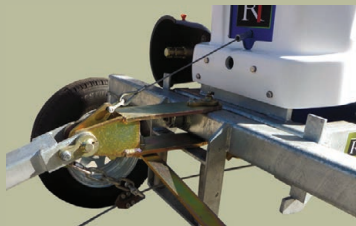

ROBUST CONSTRUCTION

- Easy to tow.
- No jack needed to support draw bar.
- Pivoting from axle adjusts to uneven terrain.



PURGE PUMP

- High quality, high volume.
- Robust purge for faster, trouble free purging.



P.T.O. CONNECTIONS AT FRONT

- Hose purge and hose wind-up operations are carried out from the towing position. This means machine anchorage and convenience of operation.



WHEN PERFORMANCE MATTERS

In the field of large-volume sprinklers, Nelson Big Guns® are recognized the world over as the leader in quality and performance. They are engineered and precision manufactured for heavy-duty reliability and long wear life with minimum maintenance required. Every Nelson Big Gun® is subjected to the toughest inspection testing and quality control standards in the industry.

TURBO WINCH

TURBO WINCH

RI 350T



MACHINE DETAILS

Sprinkler:	Nelson SR150 21° - Nelson SR200 21°
Hose:	3" to 3.5" Hose up to 200m 4" Hose up to 150m
Flow Rate:	12.43 to 39.50 litres per second
Operating Pressure Range:	482 to 620 kPa
Travel Distance Per Run:	Up to 400 metres
Wetted Width:	92 to 136 metres
Driving Mechanism:	Exclusive Radial Inflow Turbine. Specifically designed for travelling irrigator requirements. Delivers high torque at low RPMs; especially efficient when under load.
Construction:	Robust construction. Easily attaches to towing vehicle no jack needed to support draw bar.
Hose Reel:	Fully welded, galvanized hose reel.

MACHINE FEATURES

- Australian designed and manufactured
- Radial inflow turbine
- Fully galvanized chassis
- Travel shut off mechanism
- Industrial type 4 speed gearbox
- Four wheel stance
- Safe and easy operation
- Robust construction
- Spare parts and backup service available

Size	Code	Price
BASE IRRIGATOR		
• Hose reel with 410 m x 7 mm wire rope		
• Purge Kit (MEC1000 Vacuum Pump)		
• 175/75 x 14" Galvanized Steel rims & tyres	25006	39,080.80
• PTO Shaft		
• Fully galvanized chassis		
• Brake Kit		

Machine Options	Code	Price
Floation (Wide wheels)	76744UG	984.10

Irrigation Gun Options	Code	Price
Nelson Big Gun SR150 Complete	SR150K	4,974.40
Nelson Big Gun SR200 Complete	SR200K	7,721.90

Connection Options	Code	Price
3" x 4" Hose coupling with lock ring	9992	193.40
3½" x 4" Hose coupling with lock ring	9997	214.50
4" x 4" Hose coupling with lock ring	9994	392.80

Please note: Sprinkler and Hose is optional and is not included in the base kit.

TURBO WINCH

TURBO WINCH

RI 450T



MACHINE DETAILS

Sprinkler:	Nelson SR150 21° - Nelson SR200 21°
Hose:	4" to 4.5" Hose up to 200m
Flow Rate:	18.65 to 53.99 litres per second
Operating Pressure Range:	482 to 620 kPa
Up to 400 metres	Up to 400 metres
Wetted Width:	104 to 146 metres
Driving Mechanism:	Exclusive Radial Inflow Turbine. Specifically designed for travelling irrigator requirements. Delivers high torque at low RPMs; especially efficient when under load.
Construction:	Robust construction. Easily attaches to towing vehicle no jack needed to support draw bar.
Hose Reel:	Fully welded, galvanized hose reel.

MACHINE FEATURES

- Australian designed and manufactured
- Radial inflow turbine
- Fully galvanized chassis
- Travel shut off mechanism
- Industrial type 4 speed gearbox
- Four wheel stance
- Safe and easy operation
- Robust construction
- Spare parts and backup service available

Size	Code	Price
BASE IRRIGATOR		
• Hose reel with 410 m x 8 mm wire rope		
• Purge Kit (MEC1600 Vacuum Pump)		
• 225/65 x 15" Galvanized Steel rims & tyres	25007	42,175.20
• PTO Shaft		
• Fully galvanized chassis		
• Brake Kit		

Machine Options	Code	Price
Floatation (Wide wheels)	76745UG	1,015.10

Irrigation Gun Options	Code	Price
Nelson Big Gun SR150 Complete	SR150K	4,974.40
Nelson Big Gun SR200 Complete	SR200K	7,721.90

Connection Options	Code	Price
3½" x 4" Hose coupling with lock ring	9997	214.50
4" x 4" Hose coupling with lock ring	9994	392.80
4½" x 4" Hose coupling with lock ring	9999	254.10

Please note: Sprinkler is optional and is not included in the base kit.

TURBO WINCH

WEIGHTS & DIMENSIONS

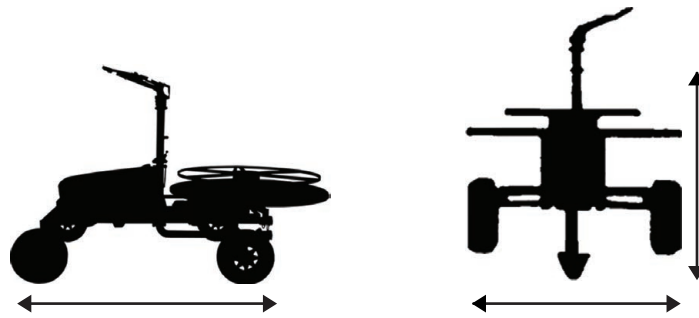

Model	Ground Clearance (mm)	Length (mm)	Width (mm)	Height (mm)	Weight (kgs)
RI 350T	250	4000	1830	2000	875
RI 450T	250	4500	1950	2000	1200

Weight does not include gun or hose.

Please note weights and dimensions are to be used as a guide only. Contact Rodney Industries or your local distributor for more detailed specifications.



HOSE TRAILERS

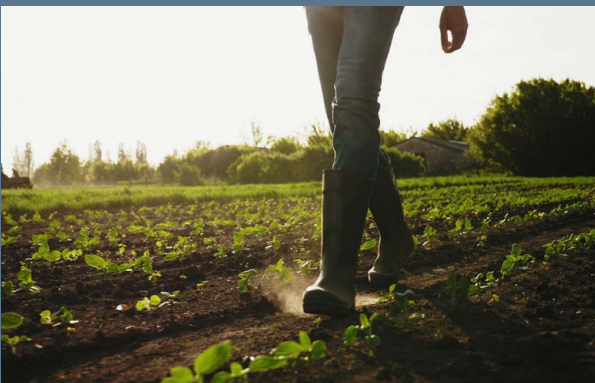

There are many other features that allow our Hose Trailers to stand out from the competitors, here are just a few:

Chassis

- Heavy Construction
- Fully galvanised
- High clearance

Pantograph Roller Arm

- Adjustable to allow the hose to be laid out either side of lane way.

Hose Reel Drive Release

- Manually disengage drive for easy hose layout.

Hose Reel

- Easy to operate
- Heavy tubular steel spool.
- Hose reel accepts the hose at a wide variety of angles. The flat base is for maximum hose protection to maximise hose life. An adjustable hose reel brake is fitted for better control on the hose layout operation.

P.T.O. Hose reel Rewind

- The P.T.O. is permanently fitted to allow hose retrieval to be carried out while in the towing position.

HOSE TRAILER

Ground Clearance (mm)	Length (mm)	Width (mm)	Height (approx. mm)	Weight (approx. kg)
400	3400	2000	1400	450

- Hose Sizes: 3.5" upto 4.5".
- Maximum Hose Length: Double reel - 2 x 200m.
- Please note that weight and height will vary depending upon model.



HT45/2 Single Reel Hose Trailer

Size	Code	Price
No purge kit fitted		
To suit up to 4½" x 300m Hose	25000	16,962.70
225/ 65 x 15" Galvanized steel rims & tyres		



HT45/4 Double Reel Hose Trailer

Size	Code	Price
No purge kit fitted		
To suit up to 4½" x 400m Hose	25002	19,811.70
- 2 x 200m hose combination		
225/65 x 15" Galvanized steel rims & tyres		

Optional Extras	Code	Price
Mec1000 Purge	76905	3,654.80
Mec1600 Purge	76923	3,441.10



MARANI

HARD HOSE IRRIGATORS



Marani has one of the largest specific ranges of poly reel irrigators available in all markets worldwide ranging from a 40mm to a 160mm machine.



Marani assemble and offers to their customers the fourth generation turbine system, providing excellent results even at very low pressures: 2-3 bar when using the spray boom and 5-6 bar when using the rain gun.

The choke-flow turbine with built in bypass and flanged directly to a gearbox represents a significant advance in hose reel irrigators drive system and makes the system very reliable for a performance point of view.

Every machine is complete with its manuals and instruction stickers, spare parts lists and performance sheets, everything the end user needs for running the machine easily.

WHY MARANI HARD HOSE IRRIGATORS?

FULLY GALVANIZED

- Corrosion resistance
- Extra durability

FOURTH GENERATION CHOKE FLOW

- Lower pressure loss over turbine
- More economical to run
- Gives a wider speed control range
- Direct coupled to gearbox

HDPE HOSE

- Manufactured to resist heavy drags
- Will work at high pressures

TACHOMETER

- Retraction speed can be instantly read out

DRUM SUPPORTS

- Drums are supported by large water proof bearings increasing drum life

Hose Guide System – Scroll Bar

- Guarantees a perfect layering of the PE hose
- Reduces hose wear to a minimum





MARANI HARD HOSE IRRIGATORS



FREQUENTLY ASKED QUESTIONS

Being Italian made, are there spare parts readily available?

We already have a huge range of spare parts not only for Marani machines but for some other well known brands which are readily available in Brisbane.

Will I get back up support?

Yes. Rodney Industries and Vinidex are embarking on establishing a solid back up team to the industry with having 3 people dedicated to irrigator sales and support through RI and a team of sales people in every state to help with your enquiries. This adds up to approximately 20 people nationally for support.

Will I save money compared to other hard hose gun options?

Yes. Due to the next generation turbine which is coupled to the gearbox and the HDPE pipe; it will work at a lower operating pressure to other machines on the market. This will mean that you can get lower energy bills, but also that you can get the higher flows required through smaller machines; saving on the capital outlay as well!

Why is it they use HDPE pipe?

HDPE is stronger and has the ability to have a larger internal bore creating less friction loss whilst being able to take increase flows of water. Being a stronger PE, the likelihood of seeing damages to the pipe and gaining an extended life.

Can I pump effluent?

Yes they can pump effluent; so long as it is fairly clean. They are pumping effluent in all parts of the world as many places around the globe only have effluent available to them for pumping in their agricultural markets.

I may want to put a boom attachment on at a later date; is it possible?

This is as easy as unbolting the flange of the gun trolley and re-bolting the boom onto it. Of course you will have to adjust your pump to work within the pressures and flows of the booms specifications. We offer the Briggs range of folding booms which is universally recognized as the best booms in the industry.

Are they strong and durable machines?

Marani is recognized globally as having one of the strongest built machines. They have been building machines since 1970 and have stood the test of time. They have a very solid chassis and use the best technology available throughout the entire machine. Their gearbox is super tough whilst having a very user friendly gearbox and turbine structure.

Are they stable when operating?

Yes. Marani have a very strong and over engineered frame design. They go to such lengths in creating a machine that won't move that even their smallest machines have a full chassis to operate from.

Will they maintain a consistent travelling speed?

Due to the full Marani range having a mechanical compensator which is adjustable, they maintain a very consistent travelling speed throughout the run. This can also be upgraded to a computer to have a more accurate timing of the run.

THE MARANI TURBINES

Turbine system for GT models

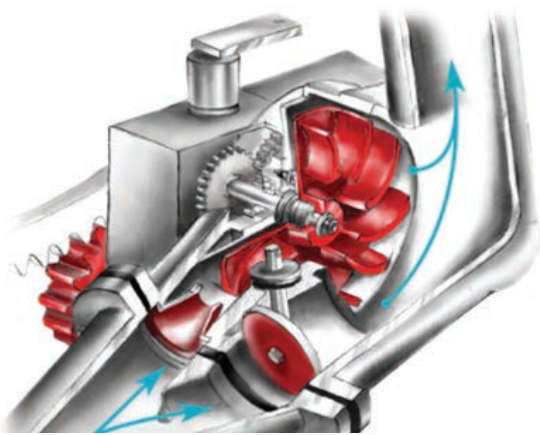

Marani Fourth Generation Turbine and Gearbox used on GT Machines are proven for Low Pressure applications and the Gearbox has been used for Both Gun Trolley Boom Irrigators for over 10 years.

The Choked-Flow Turbine with built in bypass is flanged directly to the Gearbox. This also eliminates a Transmission belt and external by pass. This makes the system reliable from a performance point of view Turbine is made with special Aluminium and machined using CNC machining Centre.

Turbine system for GTS and ITS models

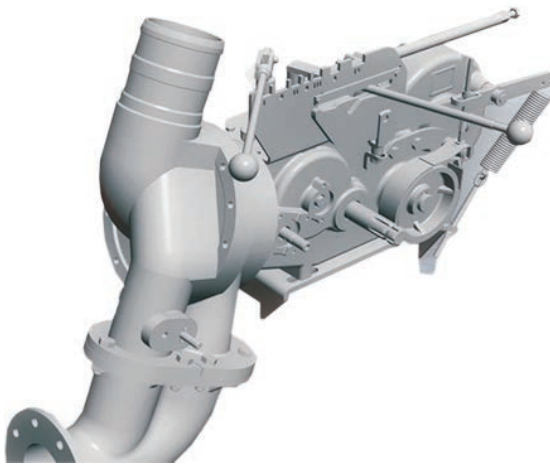

The Marani GTS and ITS Models use the most efficient turbine on the market and when direct coupled with the new Gearbox they are proven to require less water and pressure, allowing more to flow through to your gun.

You can also easily see what speed you are in with the top gear change: 1-2-3-4.

- With the Lower gear change when in the Left position: hose is ready to pull-out & PTO wind-up.
- Centre position: drum lock down for transport
- Right position: working position

If a Foreign Object jams up the impeller just reverse the impeller by turning the outlet shaft next to turbine.



MARANI HARD HOSE IRRIGATORS

CONTROLLER OPTIONS

MA RAIN 26



The MA-Rain 26 computer features the following programmable functions:

- Working speed in mt\h or ft\h.
- Delayed start (in minutes) before retraction starts.
- Delayed stop (in minutes) before opening or closing the discharge valve (optional) or the shut-off valve (optional).

The monitor then indicates:

- Remaining working time in hours and minutes.
- Working speed in mt\h or ft\h.
- Meters\feet of unwound hose.

MA RAIN 56



The MA-Rain 56 computer features the following:

- Compact case.
- 4" high contrast, colour display.
- Optical encoder, for a fast selection of settings.
- 2 x 4 keys for navigation with back lighting.
- Additional keys for alarm setting.
- I/O control module.
- On/Off key.
- Commands and features have an intuitive graphical user interface, to avoid keys in the lingo.
- Detailed alarm chart, with explicit reference to the components.
- Fast and easy parameters'/datas' settings.
- Software's update with USB key.

DIGITAL IRRIGATION 4.0



The Marani digital irrigation system analyses and conveys your irrigation scenario to the mobile device of your choice.

Location of the machines, lines to be travelled during the work phases and a volume of processed information that suggests how much water to distribute and where. As the weather and ground moisture conditions change, the software reworks the parameters and provides the new situation. Your intervention is as timely as using your fingers to press a button on the touch display.

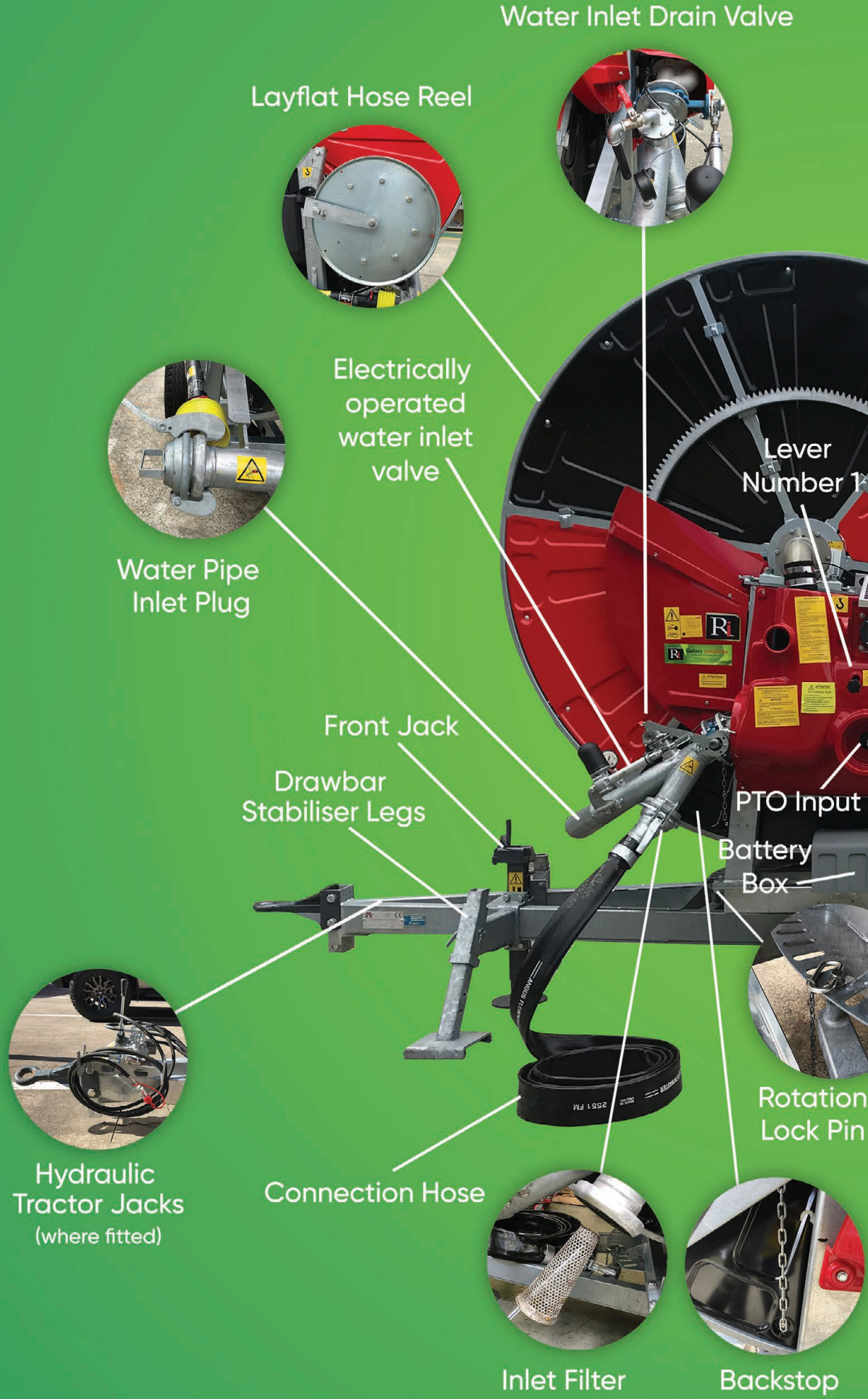

Water Inlet Drain Valve

Layflat Hose Reel

Electrically operated water inlet valve

Water Pipe Inlet Plug

Front Jack

Drawbar Stabiliser Legs

Hydraulic Tractor Jacks (where fitted)

Connection Hose

Inlet Filter

Backstop

Lever Number 1

PTO Input

Battery Box

Rotation Lock Pin

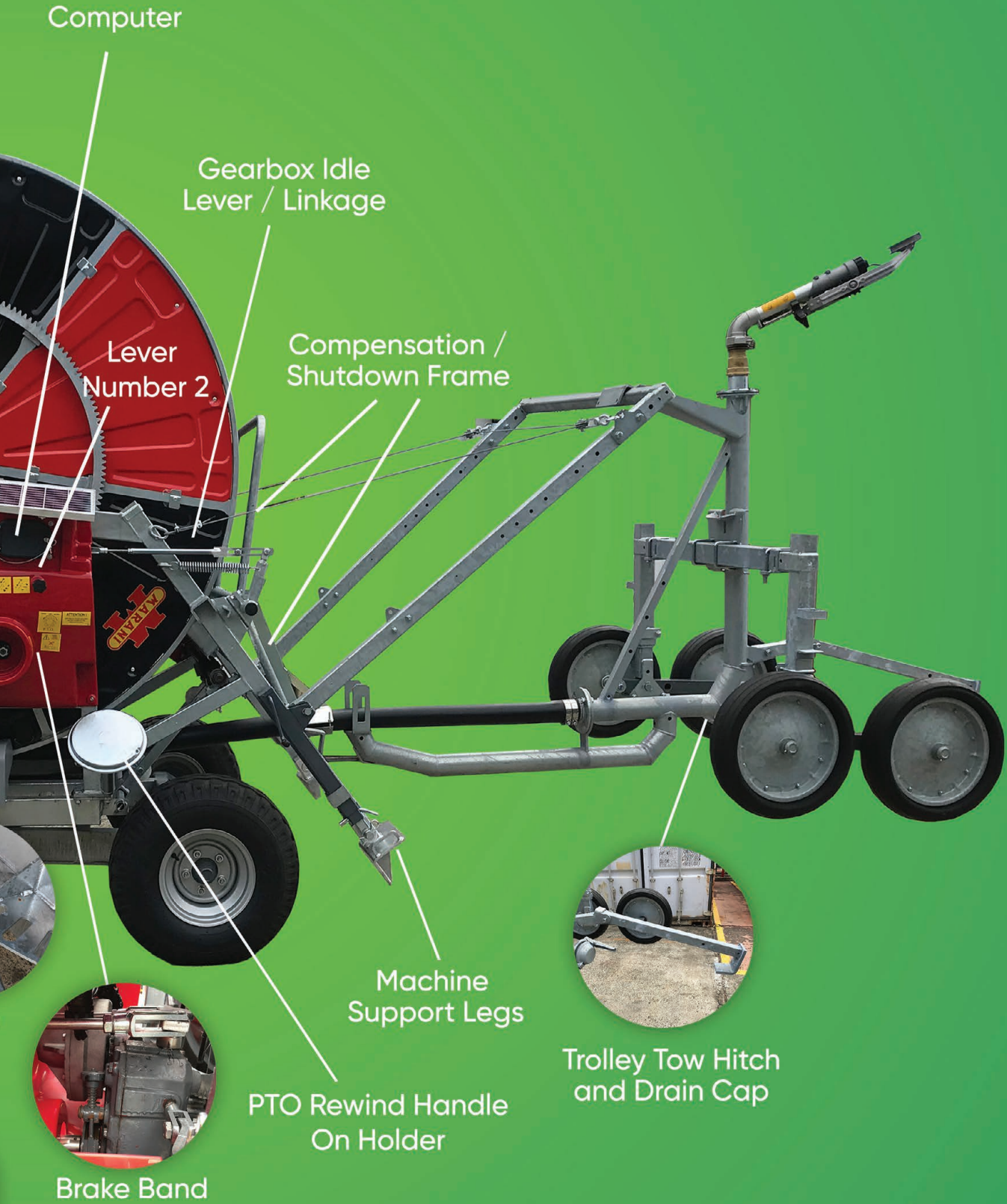

MARANI HARD HOSE IRRIGATORS



CUSTOMER ENQUIRY FORM

CONTACT INFORMATION

Company Name:

Contact Name:

Email:

Phone:

Job Name / Number:

HARD HOSE SELECTION

Hard hose Model (If already known):

Flow Rate: Ltr/Min

Pressure at Inlet: Bar

Run Length: Mtr

Hose Diameter: mm

Target Wetted Width: Mtr

Application Required: Irrigation Gun Boom Both None

Crop Row Spacing: Mtr

Crop Height: Mtr

Maximum Gradients: %

HARD HOSE OPTIONS

Gun Type (SIME as standard): SIME Nelson Komet Model:

Computer: MaRain 26 MaRain 56 None

Full Hydraulics: Yes No

Emptying Compressor: Yes No

Dump Valve (H/P Valve as Standard): Yes No

Engine Drive Retraction: Yes No

Engine Drive with pump / booster: Yes No

Irrigation 4.0 Cloud Device: Yes No

GSM - Remote Control / Alarms: Yes No Type:

Wireless Hose Measuring Device: Yes No

Hydrant Connection Fitting: Yes No

Rodney Industries Commissioning of Machine: Yes No

Transportation Required?: Yes No

Details Below:



FIELD LAYOUT

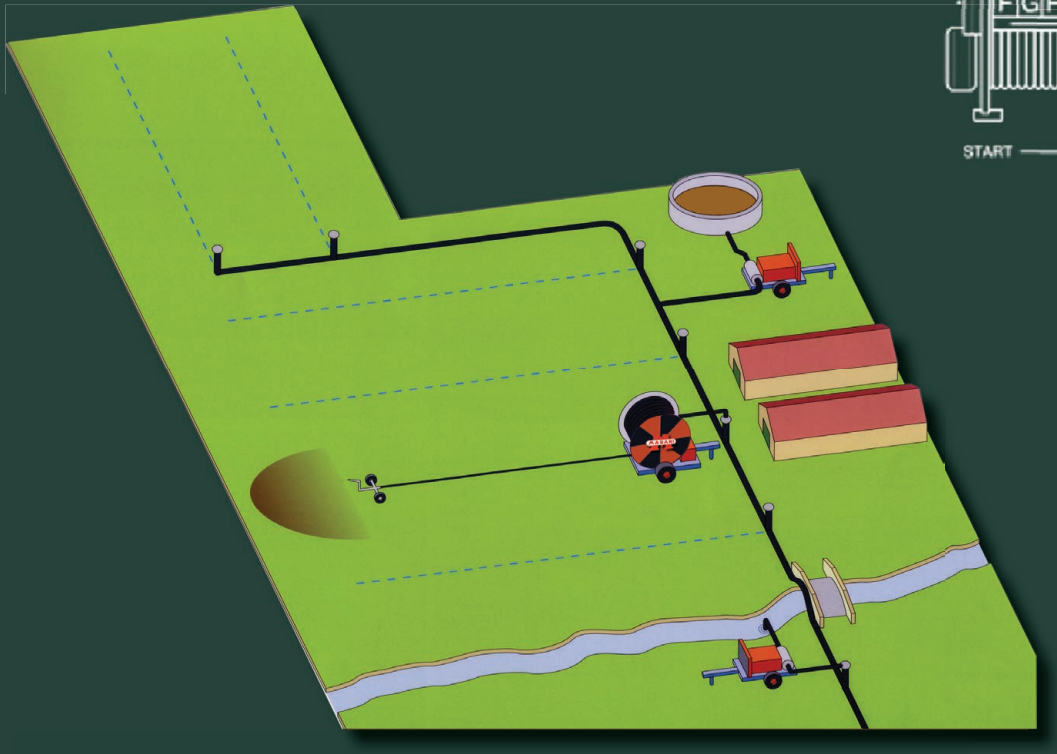

THE RANGE



F010B



GT015B



GT020B



GT022B



GT026B



GT030B/C



GT040C



GT050B



GT060B



GT070B



GTS080B/C



GTS090B/C



IT050B



IT060B



IT070B



ITS080B/C



ITS090C



IT100B



MARANI HARD HOSE IRRIGATORS

MARANI HARD HOSE IRRIGATORS

F010B 40mm x 130m

Item Code: F010B40130



STANDARD EQUIPMENT

- SIME K1 24° Part Circle Gun and nozzles
- Pressure gauge (glycerine bath)
- Mechanical feet
- Hot galvanized chassis and reel
- Single Gear Multi Speed gearbox
- Winding handle
- Water Inlet Shut-Off Valve
- Safety guards
- Flexible connection pipe 2" x 6m
- Galvanized raingun trolley
- Turbine flanged on the gearbox with external bypass
- Hose reel brake
- Water filter

TECHNICAL DATA

Pressure at Inlet (BAR)	Flow Rate (L/M)	Wetted Width at 80% (Mtr)
3.6 - 7.7	71 - 155	28 - 34

Model	Code	Price
F010B 40mm x 130m	F010B40130	18,419.00

Controller Options	Code	Price
Computer Ma-Rain 26 kit c/w solar panel and pressure switch	35462701KIT	2,765.30

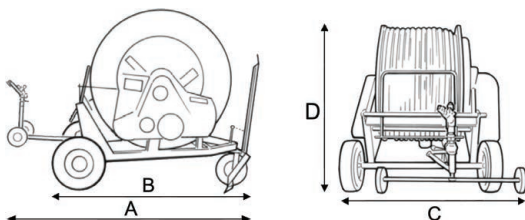

WEIGHTS AND DIMENSIONS

SIZE (cm)			
A	B	C	D
195	150	128	126

Dry Weight 320 kg

* Please note dimensions and weights are to be used as a guide only.

MARANI HARD HOSE IRRIGATORS



F010B

50mm x 170m

Item Code: F010B50170



STANDARD EQUIPMENT

- SIME Hidra Part Circle Gun and nozzles
- Pressure gauge (glycerine bath)
- Mechanical feet
- Hot galvanized chassis and reel
- Single Gear Multi Speed gearbox
- Winding handle
- Water Inlet Shut-Off Valve
- Safety guards
- Flexible connection pipe 2" x 6m
- Galvanized raingun trolley
- Turbine flanged on the gearbox with external bypass
- Hose reel brake
- Water filter

TECHNICAL DATA

Pressure at Inlet (BAR)	Flow Rate (L/M)	Wetted Width at 80% (Mtr)
3.1 – 8.8	88-277	29-46

Model	Code	Price
F010B 50mm x 170m	F010B50170	22,600.00

Controller Options	Code	Price
Computer Ma-Rain 26 kit c/w solar panel and pressure switch	35462701KIT	2,765.30

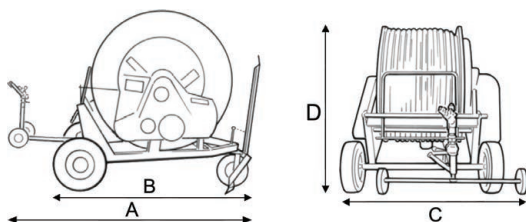

WEIGHTS AND DIMENSIONS

SIZE (cm)			
A	B	C	D
279	190	130	162

Dry Weight 450 kg

* Please note dimensions and weights are to be used as a guide only.

MARANI HARD HOSE IRRIGATORS



MARANI HARD HOSE IRRIGATORS

MARANI HARD HOSE IRRIGATORS

GT015B 58mm x 200m

Item Code: GT015B58200



STANDARD EQUIPMENT

- SIME Hidra Part Circle and nozzles
- Pressure gauge (glycerine bath)
- Mechanical feet
- Hot galvanized chassis and reel
- Single Gear Multi Speed gearbox
- Winding handle
- Water Inlet Shut-Off Valve
- Safety guards
- Flexible connection pipe 2" x 10m
- Galvanized raingun trolley
- Turbine flanged on the gearbox with external bypass
- Water filter

TECHNICAL DATA

Pressure at Inlet (BAR)	Flow Rate (L/M)	Wetted Width at 80% (Mtr)
3.3 - 8.0	152 - 351	32 - 48

Model	Code	Price
GT015B 58mm x 200m	GT015B58200	27,283.80

Controller Options	Code	Price
Computer Ma-Rain 26 kit c/w solar panel and pressure switch	35462701KIT	2,765.30

Sprinkler Upgrade Options	Code	Price
Nelson P85 Gun	RGUPHID-P85	916.90

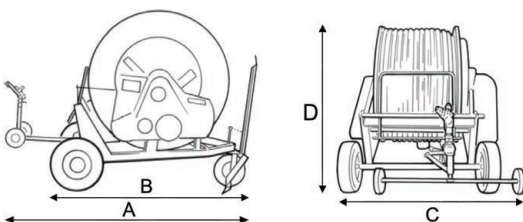

WEIGHTS AND DIMENSIONS

SIZE (cm)			
A	B	C	D
330	250	130	192

Dry Weight 653 kg

* Please note dimensions and weights are to be used as a guide only.

MARANI HARD HOSE IRRIGATORS



GT015B 63mm x 150m

Item Code: GT015B63150



STANDARD EQUIPMENT

- SIME Hidra Part Circle and nozzles
- Pressure gauge (glycerine bath)
- Mechanical feet
- Hot galvanized chassis and reel
- Single Gear Multi Speed gearbox
- Winding handle
- Water Inlet Shut-Off Valve
- Safety guards
- Flexible connection pipe 2" x 10m
- Galvanized raingun trolley
- Turbine flanged on the gearbox with external bypass
- Water filter

TECHNICAL DATA

Pressure at Inlet (BAR)	Flow Rate (L/M)	Wetted Width at 80% (Mtr)
3.0 - 9.7	174 - 560	41 - 70

Model	Code	Price
GT015B 63mm x 150m	GT015B63150	32,770.00

Controller Options	Code	Price
Computer Ma-Rain 26 kit c/w solar panel and pressure switch	35462701KIT	2,765.30

Sprinkler Upgrade Options	Code	Price
Nelson P85 Gun	RGUPHID-P85	916.90

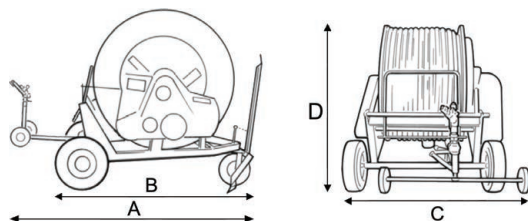

WEIGHTS AND DIMENSIONS

SIZE (cm)			
A	B	C	D
330	250	130	192

Dry Weight 635 kg

* Please note dimensions and weights are to be used as a guide only.



MARANI HARD HOSE IRRIGATORS

MARANI HARD HOSE IRRIGATORS

GT020B 63mm x 200m

Item Code: GT020B63200



STANDARD EQUIPMENT

- Ma-Rain 26 Kit c/w solar panel and pressure switch
- SIME Hidra Part Circle and nozzles
- Mechanical lifting device trolley
- Hot galvanized chassis and reel
- Telescopic mechanical feet
- Winding handle
- Single speed gearbox
- Safety guards
- Galvanized raingun trolley mounted on variable track wheels
- P.T.O.
- Flexible connection pipe 2" x 10m
- Pressure gauge (glycerine bath)
- Turbine flanged on the gearbox with external by-pass
- Water inlet shut off
- Pressure switch
- Water filter

TECHNICAL DATA

Pressure at Inlet (BAR)	Flow Rate (L/M)	Wetted Width at 80% (Mtr)
3.9 - 7.4	195 - 532	34 - 51

Model	Code	Price
GT020B 63mm x 200m	GT020B63200	36,838.00

Sprinkler Upgrade Options	Code	Price
Nelson P85 Gun	RGUPHID-P85	916.90
Wireless Measuring System for Ma-Rain 56 computer	35400350SKIT	1,803.50

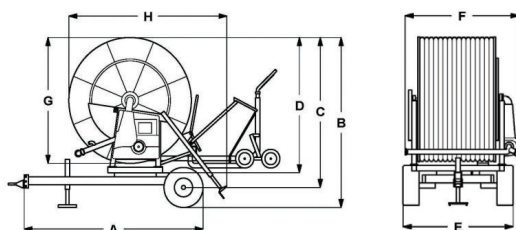

WEIGHTS AND DIMENSIONS

SIZE (cm)							
A	B	C	D	E	F	G	H
240	218	192	200	166	135	158	175

Dry Weight 856 kg

* Please note dimensions and weights are to be used as a guide only.

MARANI HARD HOSE IRRIGATORS



GT022B

63mm x 250m

Item Code: GT022B63250



STANDARD EQUIPMENT

- Ma-Rain 26 Kit c/w solar panel and pressure switch
- SIME Hidra Part Circle and nozzles
- Mechanical lifting device of trolley
- Flexible connection pipe with storage reel
- Telescopic mechanical feet
- Pressure gauge (glycerine bath)
- 3 Speed gearbox
- PTO
- Hot galvanized chassis and reel
- Winding handle
- Water Inlet Shut-Off Valve
- Safety guards
- Turbine mounted on the gearbox with built-in bypass
- Galvanized raingun trolley mounted on variable track hard rubber wheels
- Water filter

TECHNICAL DATA

Pressure at Inlet (BAR)	Flow Rate (L/M)	Wetted Width at 80% (Mtr)
4.0 - 10.1	230 - 520	40 - 54

Model	Code	Price
GT022B 63mm x 250m	GT022B63250	48,477.00

Controller Options	Code	Price
No on board Computer	DED35462703KIT	POA
Ma-Rain 56 Kit	35510120SKIT	7,391.80
Digital 4.0 Router option for Ma-Rain 56	35400262	10,426.50
Wireless Measuring System for Ma-Rain 56 computer	35400350SKIT	1,803.50

Sprinkler Upgrade Options	Code	Price
Nelson P85 Gun	RGUPHID-P85	916.90

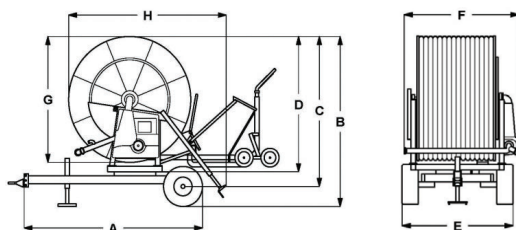

WEIGHTS AND DIMENSIONS

SIZE (cm)							
A	B	C	D	E	F	G	H
290	230	200	180	175	170	169	225

Dry Weight 1047 kg

* Please note dimensions and weights are to be used as a guide only.



MARANI HARD HOSE IRRIGATORS

MARANI HARD HOSE IRRIGATORS

GT022B

75mm x 250m

Item Code: GT022B75250



STANDARD EQUIPMENT

- Ma-Rain 26 Kit c/w solar panel and pressure switch
- SIME Royal and nozzles
- Mechanical lifting device of trolley
- Flexible connection pipe with storage reel
- Telescopic mechanical feet
- Pressure gauge (glycerine bath)
- 3 Speed gearbox
- PTO
- Hot galvanized chassis and reel
- Winding handle
- Water Inlet Shut-Off Valve
- Safety guards
- Turbine mounted on the gearbox with built-in bypass
- Galvanized raingun trolley mounted on variable track hard rubber wheels
- Water filter

TECHNICAL DATA

Pressure at Inlet (BAR)	Flow Rate (L/M)	Wetted Width at 80% (Mtr)
4.4 - 10.8	276 - 708	51 - 75

Model	Code	Price
GT022B 75mm x 250m	GT022B75250	50,285.00

Controller Options	Code	Price
No on board Computer	DED35462703KIT	POA
Ma-Rain 56 Kit	35510120SKIT	7,391.80
Digital 4.0 Router option for Ma-Rain 56	35400262	10,426.50
Wireless Measuring System for Ma-Rain 56 computer	35400350SKIT	1,803.50

Sprinkler Upgrade Options	Code	Price
Nelson SR100 Gun	RGUPROY-SR100K	1,650.40
Komet 101 Ultra Kit	RGUPROY-K101U	102.80

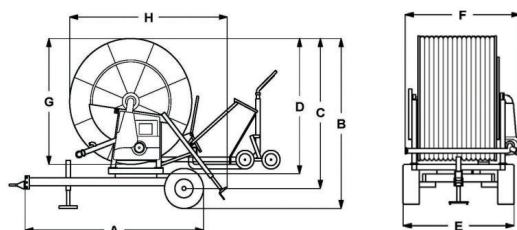

WEIGHTS AND DIMENSIONS

SIZE (cm)							
A	B	C	D	E	F	G	H
290	230	200	180	175	170	169	225

Dry Weight 1047 kg

* Please note dimensions and weights are to be used as a guide only.

MARANI HARD HOSE IRRIGATORS



GT026B

75mm x 300m

Item Code: GT026B75300



STANDARD EQUIPMENT

- Ma-Rain 26 Kit c/w solar panel and pressure switch
- SIME Royal and nozzles
- Mechanical lifting device of trolley
- Pressure gauge (glycerine bath)
- Telescopic mechanical feet
- 3 Speed gearbox
- Hot galvanized chassis and reel
- PTO
- Water Inlet Shut-Off Valve
- Galvanized raingun trolley mounted on variable track hard rubber wheels
- Turbine mounted on the gearbox with built-in bypass
- Winding handle
- Safety guards
- Flexible connection pipe with storage reel
- Water filter

TECHNICAL DATA

Pressure at Inlet (BAR)	Flow Rate (L/M)	Wetted Width at 80% (Mtr)
3.0 – 10.4	174 – 586	40 – 72

Model	Code	Price
GT026B 75mm x 300m	GT026B75300	58,534.00

Machine Options	Code	Price
Full Hydraulics	80420300	4,400.30

Controller Options	Code	Price
No on board Computer	DED35462703KIT	POA
Ma-Rain 56 Kit	35510120SKIT	7,391.80
Digital 4.0 Router option for Ma-Rain 56	35400262	10,426.50
Wireless Measuring System for Ma-Rain 56 computer	35400350SKIT	1,803.50

Sprinkler Upgrade Options	Code	Price
Nelson SR100 Gun	RGUPROY-SR100K	1,650.40
Komet 101 Ultra Kit	RGUPROY-K101U	102.80

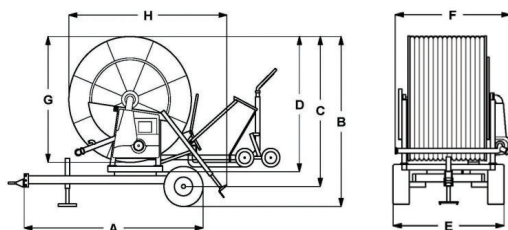

WEIGHTS AND DIMENSIONS

SIZE (cm)							
A	B	C	D	E	F	G	H
325	265	235	225	195	193	199	255

Dry Weight 1300 kg

* Please note dimensions and weights are to be used as a guide only.

MARANI HARD HOSE IRRIGATORS



MARANI HARD HOSE IRRIGATORS

MARANI HARD HOSE IRRIGATORS

GT026B 90mm x 250m

Item Code: GT026B90250



STANDARD EQUIPMENT

- Ma-Rain 26 Kit c/w solar panel and pressure switch
- SIME Reflex and nozzles
- Mechanical lifting device of trolley
- Pressure gauge (glycerine bath)
- Telescopic mechanical feet
- 3 Speed gearbox
- Hot galvanized chassis and reel
- PTO
- Water Inlet Shut-Off Valve
- Galvanized raingun trolley mounted on variable track hard rubber wheels
- Turbine mounted on the gearbox with built-in bypass
- Winding handle
- Safety guards
- Flexible connection pipe with storage reel
- Water filter

TECHNICAL DATA

Pressure at Inlet (BAR)	Flow Rate (L/M)	Wetted Width at 80% (Mtr)
4.6 – 10.9	522 – 1149	59 – 86

Model	Code	Price
GT026B 90mm x 250m	GT026B90250	65,427.00

Machine Options	Code	Price
Full Hydraulics	80420300	4,400.30

Controller Options	Code	Price
No on board Computer	DED35462703KIT	POA
Ma-Rain 56 Kit	35510120SKIT	7,391.80
Digital 4.0 Router option for Ma-Rain 56	35400262	10,426.50
Wireless Measuring System for Ma-Rain 56 computer	35400350SKIT	1,803.50

Sprinkler Upgrade Options	Code	Price
Nelson SR150 Gun	RGUPREF-SR150K	2,976.50
Komet 101 Ultra Kit	RGUPROY-K101U	102.80

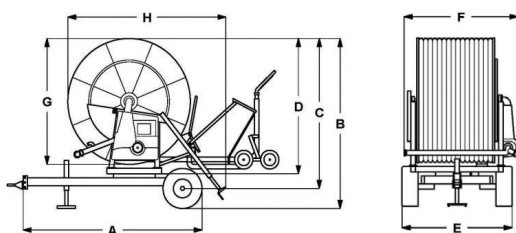

WEIGHTS AND DIMENSIONS

SIZE (cm)							
A	B	C	D	E	F	G	H
325	265	235	225	195	193	199	255

Dry Weight 1300 kg

* Please note dimensions and weights are to be used as a guide only.

MARANI HARD HOSE IRRIGATORS



GT030B

75mm x 350m

Item Code: GT030B75350



STANDARD EQUIPMENT

- Ma-Rain 26 Kit c/w solar panel and pressure switch
- SIME Royal and nozzles
- Mechanical lifting device of trolley
- Hot galvanized chassis and reel
- Telescopic mechanical feet
- Pressure gauge (glycerine bath)
- 6 Speed gearbox
- PTO
- Flexible connection pipe with storage reel
- Turbine mounted on the gearbox with built-in bypass
- Galvanized raingun trolley mounted on variable track hard rubber wheels
- Safety guards
- Water Inlet Shut-Off Valve
- Winding handle
- Water filter

TECHNICAL DATA

Pressure at Inlet (BAR)	Flow Rate (L/M)	Wetted Width at 80% (Mtr)
3.0 – 10.8	174 – 586	40 – 72

Model	Code	Price
GT030B 75mm x 350m	GT030B75350	58,415.40

Machine Options	Code	Price
Full Hydraulics	80430300	4,400.30
Emptying Compressor	80590000SKIT	6,771.40

Controller Options	Code	Price
No on board Computer	DED35462700KIT	POA
Ma-Rain 56 Kit	35510120SKIT	7,391.80
Digital 4.0 Router option for Ma-Rain 56	35400262	10,426.50
Wireless Measuring System for Ma-Rain 56 computer	35400350SKIT	1,803.50

Sprinkler Upgrade Options	Code	Price
Nelson SR100 Gun	RGUPROY-SR100K	1,650.40
Komet 101 Ultra Kit	RGUPROY-K101U	102.80

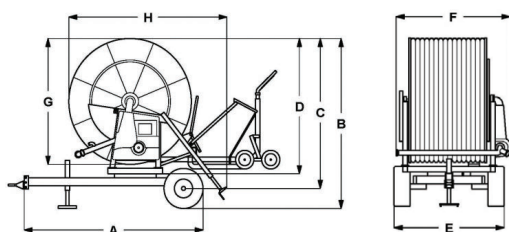

WEIGHTS AND DIMENSIONS

SIZE (cm)							
A	B	C	D	E	F	G	H
330	296	265	245	205	225	224	280

Dry Weight 1907 kg

* Please note dimensions and weights are to be used as a guide only.



MARANI HARD HOSE IRRIGATORS

MARANI HARD HOSE IRRIGATORS

GT030B

90mm x 300m

Item Code: GT030B90300



STANDARD EQUIPMENT

- Ma-Rain 26 Kit c/w solar panel and pressure switch
- SIME Reflex and nozzles
- Mechanical lifting device of trolley
- Hot galvanized chassis and reel
- Telescopic mechanical feet
- Pressure gauge (glycerine bath)
- 6 Speed gearbox
- PTO
- Flexible connection pipe with storage reel
- Turbine mounted on the gearbox with built-in bypass
- Galvanized raingun trolley mounted on variable track hard rubber wheels
- Safety guards
- Water Inlet Shut-Off Valve
- Winding handle
- Water filter

TECHNICAL DATA

Pressure at Inlet (BAR)	Flow Rate (L/M)	Wetted Width at 80% (Mtr)
4.8 – 10.8	522 – 1096	59 – 83

Model	Code	Price
GT030B 90mm x 300m	GT030B90300	61,811.00

Machine Options	Code	Price
Full Hydraulics	80430300	4,400.30
Emptying Compressor	80590000SKIT	6,771.40

Controller Options	Code	Price
No on board Computer	DED35462700KIT	POA
Ma-Rain 56 Kit	35510120SKIT	7,391.80
Digital 4.0 Router option for Ma-Rain 56	35400262	10,426.50
Wireless Measuring System for Ma-Rain 56 computer	35400350SKIT	1,803.50

Sprinkler Upgrade Options	Code	Price
Nelson SR150 Gun	RGUPREF-SR150K	2,976.50
Komet 101 Ultra Kit	RGUPREF-K101U	-189.70

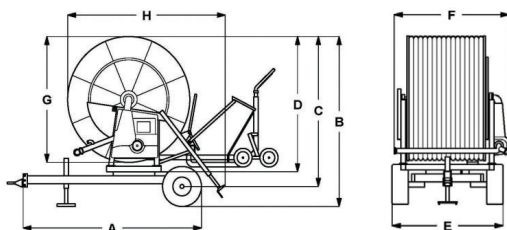

WEIGHTS AND DIMENSIONS

SIZE (cm)							
A	B	C	D	E	F	G	H
330	296	265	245	205	225	224	280

Dry Weight 1907 kg

* Please note dimensions and weights are to be used as a guide only.

MARANI HARD HOSE IRRIGATORS



GT030B

90mm x 350m

Item Code: GT030B90350

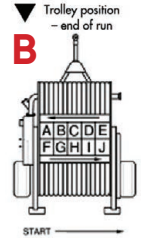

STANDARD EQUIPMENT

- Ma-Rain 26 Kit c/w solar panel and pressure switch
- SIME Reflex and nozzles
- Mechanical lifting device of trolley
- Hot galvanized chassis and reel
- Telescopic mechanical feet
- Pressure gauge (glycerine bath)
- 6 Speed gearbox
- PTO
- Flexible connection pipe with storage reel
- Turbine mounted on the gearbox with built-in bypass
- Galvanized raingun trolley mounted on variable track hard rubber wheels
- Safety guards
- Water Inlet Shut-Off Valve
- Winding handle
- Water filter

TECHNICAL DATA

Pressure at Inlet (BAR)	Flow Rate (L/M)	Wetted Width at 80% (Mtr)
5.1 - 10.8	522 - 1040	59 - 80

Model	Code	Price
GT030B 90mm x 350m	GT030B90350	62,291.30

Machine Options	Code	Price
Full Hydraulics	80430300	4,400.30
Emptying Compressor	80590000SKIT	6,771.40

Controller Options	Code	Price
No on board Computer	DED35462700KIT	POA
Ma-Rain 56 Kit	35510120SKIT	7,391.80
Digital 4.0 Router option for Ma-Rain 56	35400262	10,426.50
Wireless Measuring System for Ma-Rain 56 computer	35400350SKIT	1,803.50

Sprinkler Upgrade Options	Code	Price
Nelson SR150 Gun	RGUPREF-SR150K	2,976.50
Komet 101 Ultra Kit	RGUPREF-K101U	-189.70

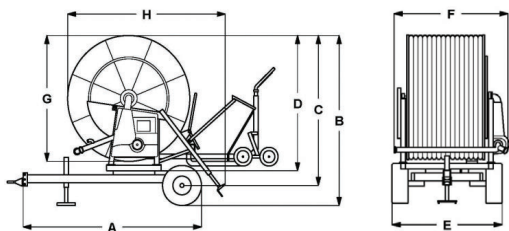

WEIGHTS AND DIMENSIONS

SIZE (cm)							
A	B	C	D	E	F	G	H
330	296	265	245	205	225	224	280

Dry Weight 1907 kg

* Please note dimensions and weights are to be used as a guide only.



MARANI HARD HOSE IRRIGATORS

MARANI HARD HOSE IRRIGATORS

GT030C 110mm x 250m

Item Code: GT030C110250



STANDARD EQUIPMENT

- Ma-Rain 26 Kit c/w solar panel and pressure switch
- SIME Reflex and nozzles
- Mechanical lifting device of trolley
- Hot galvanized chassis and reel
- Telescopic mechanical feet
- Pressure gauge (glycerine bath)
- Safety guards
- 6 Speed gearbox
- Water Inlet Shut-Off Valve
- PTO
- Flexible connection pipe with storage reel
- Winding handle
- Turbine mounted on the gearbox with built-in bypass
- Galvanized raingun trolley mounted on variable track hard rubber wheels
- Water filter

TECHNICAL DATA

Pressure at Inlet (BAR)	Flow Rate (L/M)	Wetted Width at 80% (Mtr)
3.7 - 9.9	522 - 1570	59 - 94

Description	Code	Price
GT030C 110mm x 250m	GT030C110250	71,529.00

Machine Options	Code	Price
Full Hydraulics	80430300	4,400.30
Emptying Compressor	80590000SKIT	6,771.40

Controller Options	Code	Price
No on board Computer	DED35462700KIT	POA
Ma-Rain 56 Kit	35510120SKIT	7,391.80
Digital 4.0 Router option for Ma-Rain 56	35400262	10,426.50
Wireless Measuring System for Ma-Rain 56 computer	35400350SKIT	1,803.50

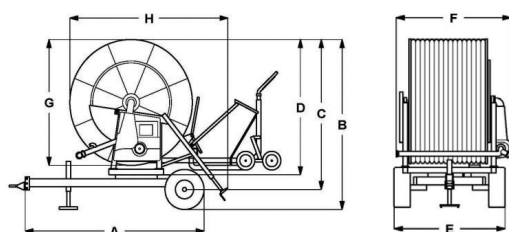

WEIGHTS AND DIMENSIONS

SIZE (cm)							
A	B	C	D	E	F	G	H
330	296	265	245	205	225	224	280

Dry Weight 1907 kg

* Please note dimensions and weights are to be used as a guide only.

MARANI HARD HOSE IRRIGATORS



GT040C

110mm x 300m

Item Code: GT040C110300



STANDARD EQUIPMENT

- Ma-Rain 26 Kit c/w solar panel and pressure switch
- SIME Reflex and nozzles
- Telescopic hydraulic feet
- Pressure gauge (glycerine bath)
- 6 Speed gearbox
- Winding handle
- Hot galvanized chassis and reel
- Safety guards
- Water Inlet Shut-Off Valve
- PTO
- Flexible connection pipe with storage reel
- Turbine mounted on the gearbox with built-in bypass
- Galvanized raingun trolley mounted on variable track hard rubber wheels
- 5 wheel trolley
- Water filter
- Hydraulic lifting of trolley
- Hydraulic rotation of turntable
- Hydraulic lifting of drawbar

TECHNICAL DATA

Pressure at Inlet (BAR)	Flow Rate (L/M)	Wetted Width at 80% (Mtr)
4.4 – 10.5	732 – 1570	66 – 94

Description	Code	Price
GT040C 110mm x 300m	GT040C110300	90,739.00

Machine Options	Code	Price
Emptying Compressor	75430550	4,250.90

Controller Options	Code	Price
Ma-Rain 56 Kit	35510120SKIT	7,391.80
No Computer	DED35462700KIT	POA
Digital 4.0 Router option for Ma-Rain 56	35400262	10,426.50
Wireless Measuring System for Ma-Rain 56 computer	35400350SKIT	1,803.50

Sprinkler Upgrade Options	Code	Price
SIME Mariner Big Gun	RGUPREF-MAR	412.30
SIME Mariner 2 Speed	RGUPREF-MAR2S	679.50
Nelson SR150 Gun	RGUPREF-SR150K	2,976.50
Komet 160 Ultra Kit	RGUPREF-K160U	213.10

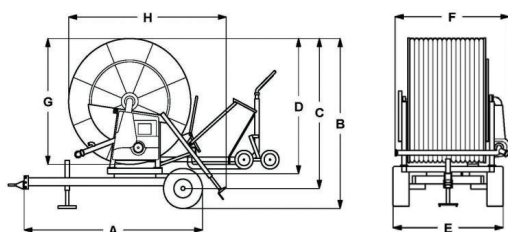

WEIGHTS AND DIMENSIONS

SIZE (cm)							
A	B	C	D	E	F	G	H
340	324	296	270	210	225	246	295

Dry Weight 2470 kg

* Please note dimensions and weights are to be used as a guide only.



MARANI HARD HOSE IRRIGATORS

MARANI HARD HOSE IRRIGATORS

GT050B

110mm x 350m

Item Code: GT050B110350



STANDARD EQUIPMENT

- Ma-Rain 26 Kit c/w solar panel and pressure switch
- SIME Reflex and nozzles
- Telescopic hydraulic feet
- Pressure gauge (glycerine bath)
- 4 Speed gearbox
- Winding handle
- Hot galvanized chassis and reel
- Safety guards
- Water Inlet Shut-Off Valve
- PTO
- Flexible connection pipe with storage reel
- Galvanized raingun trolley mounted on variable track hard rubber wheels
- Turbine mounted on the gearbox with built-in bypass
- 5 wheel trolley
- Water filter
- Hydraulic lifting of trolley
- Hydraulic rotation of turntable
- Hydraulic lifting of drawbar

TECHNICAL DATA

Pressure at Inlet (BAR)	Flow Rate (L/M)	Wetted Width at 80% (Mtr)
4.3 – 11.2	623 – 1570	62 – 94

Description	Code	Price
GT050B 110mm x 350m	GT050B110350	94,355.00

Machine Options	Code	Price
Emptying Compressor	75430550	4,250.90

Controller Options	Code	Price
Ma-Rain 56 Kit	35510120SKIT	7,391.80
No Computer	DED35462700KIT	POA
Digital 4.0 Router option for Ma-Rain 56	35400262	10,426.50
Wireless Measuring System for Ma-Rain 56 computer	35400350SKIT	1,803.50

Sprinkler Upgrade Options	Code	Price
SIME Mariner Big Gun	RGUPREF-MAR	412.30
SIME Mariner 2 Speed	RGUPREF-MAR2S	679.50
Nelson SR150 Gun	RGUPREF-SR150K	2,976.50
Komet 160 Ultra Kit	RGUPREF-K160U	213.10

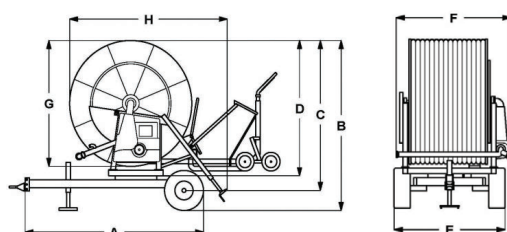

WEIGHTS AND DIMENSIONS

SIZE (cm)							
A	B	C	D	E	F	G	H
420	353	318	286	228	240	268	350

Dry Weight 2795 kg

* Please note dimensions and weights are to be used as a guide only.



**REAL PEOPLE
REAL PRODUCTS
REAL SOLUTIONS**



MARANI HARD HOSE IRRIGATORS

GT060B

110mm x 420m

Item Code: GT060B110420



STANDARD EQUIPMENT

- Ma-Rain 26 Kit c/w solar panel and pressure switch
- SIME Reflex and nozzles
- Telescopic hydraulic feet
- Pressure gauge (glycerine bath)
- 4 Speed gearbox
- Winding handle
- Hot galvanized chassis and reel
- Safety guards
- Water Inlet Shut-Off Valve
- PTO
- Flexible connection pipe with storage reel
- Galvanized raingun trolley mounted on variable track hard rubber wheels
- Turbine mounted on the gearbox with built-in bypass
- 5 wheel trolley
- Water filter
- Hydraulic lifting of trolley
- Hydraulic rotation of turntable
- Hydraulic lifting of drawbar

TECHNICAL DATA

Pressure at Inlet (BAR)	Flow Rate (L/M)	Wetted Width at 80% (Mtr)
4.6 - 10.6	623 - 1320	62 - 90

Description	Code	Price
GT060B 110mm x 420m	GT060B110420	110,966.00

Machine Options	Code	Price
Emptying Compressor	75430550	4,250.90

Controller Options	Code	Price
Ma-Rain 56 Kit	35510120SKIT	7,391.80
No Computer	DED35462700KIT	POA
Digital 4.0 Router option for Ma-Rain 56	35400262	10,426.50
Wireless Measuring System for Ma-Rain 56 computer	35400350SKIT	1,803.50

Sprinkler Upgrade Options	Code	Price
SIME Mariner Big Gun	RGUPREF-MAR	412.30
SIME Mariner 2 Speed	RGUPREF-MAR2S	679.50
Nelson SR150 Gun	RGUPREF-SR150K	2,976.50
Komet 160 Ultra Kit	RGUPREF-K160U	213.10

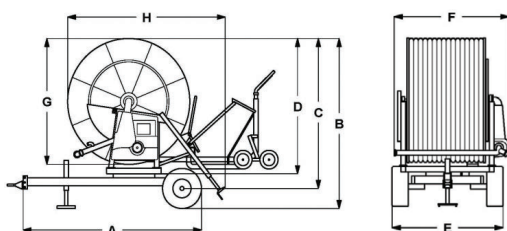

WEIGHTS AND DIMENSIONS

SIZE (cm)							
A	B	C	D	E	F	G	H
375	360	320	303	240	233	280	335

Dry Weight 3699 kg

* Please note dimensions and weights are to be used as a guide only.

MARANI HARD HOSE IRRIGATORS

MARANI HARD HOSE IRRIGATORS



GT060B

110mm x 450m

Item Code: GT060B110450



STANDARD EQUIPMENT

- Ma-Rain 26 Kit c/w solar panel and pressure switch
- SIME Reflex and nozzles
- Telescopic hydraulic feet
- Pressure gauge (glycerine bath)
- 4 Speed gearbox
- Winding handle
- Hot galvanized chassis and reel
- Safety guards
- Water Inlet Shut-Off Valve
- PTO
- Flexible connection pipe with storage reel
- Galvanized raingun trolley mounted on variable track hard rubber wheels
- Turbine mounted on the gearbox with built-in bypass
- 5 wheel trolley
- Water filter
- Hydraulic lifting of trolley
- Hydraulic rotation of turntable
- Hydraulic lifting of drawbar

TECHNICAL DATA

Pressure at Inlet (BAR)	Flow Rate (L/M)	Wetted Width at 80% (Mtr)
4.4 – 11.9	522 – 1501	59 – 91

Description	Code	Price
GT060B 110mm x 450m	GT060B110450	112,209.00

Machine Options	Code	Price
Emptying Compressor	75430550	4,250.90

Controller Options	Code	Price
Ma-Rain 56 Kit	35510120SKIT	7,391.80
No Computer	DED35462700KIT	POA
Digital 4.0 Router option for Ma-Rain 56	35400262	10,426.50
Wireless Measuring System for Ma-Rain 56 computer	35400350SKIT	1,803.50

Sprinkler Upgrade Options	Code	Price
SIME Mariner Big Gun	RGUPREF-MAR	412.30
SIME Mariner 2 Speed	RGUPREF-MAR2S	679.50
Nelson SR150 Gun	RGUPREF-SR150K	2,976.50
Komet 160 Ultra Kit	RGUPREF-K160U	213.10

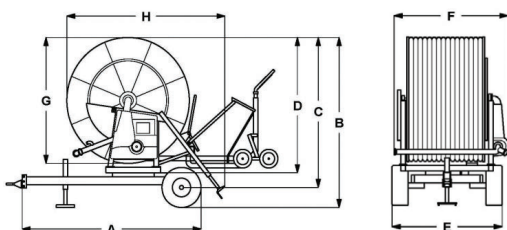

WEIGHTS AND DIMENSIONS

SIZE (cm)							
A	B	C	D	E	F	G	H
375	360	320	303	240	233	280	335

Dry Weight 3699 kg

* Please note dimensions and weights are to be used as a guide only.



MARANI HARD HOSE IRRIGATORS

MARANI HARD HOSE IRRIGATORS

GT060B 125mm x 350m

Item Code: GT060B125350



STANDARD EQUIPMENT

- Ma-Rain 26 Kit c/w solar panel and pressure switch
- SIME Explorer Big Gun and nozzles
- Telescopic hydraulic feet
- Pressure gauge (glycerine bath)
- 4 Speed gearbox
- Winding handle
- Hot galvanized chassis and reel
- Safety guards
- Water Inlet Shut-Off Valve
- PTO
- Flexible connection pipe with storage reel
- Galvanized raingun trolley mounted on variable track hard rubber wheels
- Turbine mounted on the gearbox with built-in bypass
- 5 wheel trolley
- Water filter
- Hydraulic lifting of trolley
- Hydraulic rotation of turntable
- Hydraulic lifting of drawbar

TECHNICAL DATA

Pressure at Inlet (BAR)	Flow Rate (L/M)	Wetted Width at 80% (Mtr)
4.3 – 11.2	848 – 1913	70 – 109

Description	Code	Price
GT060B 125mm x 350m	GT060B125350	106,785.00

Machine Options	Code	Price
Emptying Compressor	75430550	4,250.90

Controller Options	Code	Price
Ma-Rain 56 Kit	35510120SKIT	7,391.80
No Computer	DED35462700KIT	POA
Digital 4.0 Router option for Ma-Rain 56	35400262	10,426.50
Wireless Measuring System for Ma-Rain 56 computer	35400350SKIT	1,803.50

Sprinkler Upgrade Options	Code	Price
SIME Gemini 25° 2 Speed	RGUPEXP-GEM2S	720.80
Nelson SR150 Gun	RGUPEXP-SR200K	5,706.00
Komet 160 Ultra Kit	RGUPEXP-K160U	-30.80

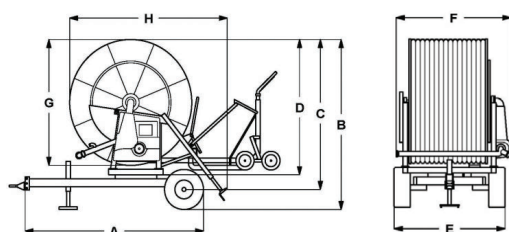

WEIGHTS AND DIMENSIONS

SIZE (cm)							
A	B	C	D	E	F	G	H
375	360	320	303	240	233	280	335

Dry Weight 3699 kg

* Please note dimensions and weights are to be used as a guide only.

MARANI HARD HOSE IRRIGATORS



GT070B

110mm x 500m

Item Code: GT070B110500



STANDARD EQUIPMENT

- Ma-Rain 26 Kit c/w solar panel and pressure switch
- SIME Reflex^o and nozzles
- Telescopic hydraulic feet
- Pressure gauge (glycerine bath)
- 4 Speed gearbox
- Winding handle
- Hot galvanized chassis and reel
- Safety guards
- Water Inlet Shut-Off Valve
- PTO
- Flexible connection pipe with storage reel
- Galvanized raingun trolley mounted on variable track hard rubber wheels
- Turbine mounted on the gearbox with built-in bypass
- 2 Large flotation wheels
- 5 Wheel trolley
- Water filter
- Hydraulic lifting of trolley
- Hydraulic rotation of turntable
- Hydraulic lifting of drawbar

TECHNICAL DATA

Pressure at Inlet (BAR)	Flow Rate (L/M)	Wetted Width at 80% (Mtr)
4.5 – 11.5	522 – 1202	59 – 88

Description	Code	Price
GT070B 110mm x 500m	GT070B110500	123,509.00

Machine Options	Code	Price
Emptying Compressor	75430550	4,250.90

Controller Options	Code	Price
Ma-Rain 56 Kit	35510120SKIT	7,391.80
No Computer	DED35462700KIT	POA
Digital 4.0 Router option for Ma-Rain 56	35400262	10,426.50
Wireless Measuring System for Ma-Rain 56 computer	35400350SKIT	1,803.50

Sprinkler Upgrade Options	Code	Price
SIME Mariner 2 Speed	RGUPREF-MAR2S	679.50
Nelson SR150 Gun	RGUPREF-SR150K	2,976.50
Komet 160 Ultra Kit	RGUPREF-K160U	213.10

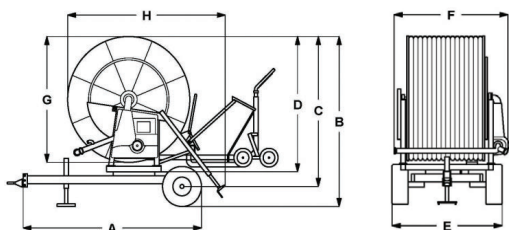

WEIGHTS AND DIMENSIONS

SIZE (cm)							
A	B	C	D	E	F	G	H
375	385	345	325	243	235	309	360

Dry Weight 3650 kg

* Please note dimensions and weights are to be used as a guide only.

MARANI HARD HOSE IRRIGATORS



MARANI HARD HOSE IRRIGATORS

MARANI HARD HOSE IRRIGATORS

GT070B 125mm x 400m

Item Code: GT070B125400



STANDARD EQUIPMENT

- Ma-Rain 26 Kit c/w solar panel and pressure switch
- SIME Explorer Big Gun 25° and nozzles
- Telescopic hydraulic feet
- Pressure gauge (glycerine bath)
- 4 Speed gearbox
- Winding handle
- Hot galvanized chassis and reel
- Safety guards
- Water Inlet Shut-Off Valve
- PTO
- Flexible connection pipe with storage reel
- Galvanized raingun trolley mounted on variable track hard rubber wheels
- Turbine mounted on the gearbox with built-in bypass
- 2 Large flotation wheels
- 5 Wheel trolley
- Water filter
- Hydraulic lifting of trolley
- Hydraulic rotation of turntable
- Hydraulic lifting of drawbar

TECHNICAL DATA

Pressure at Inlet (BAR)	Flow Rate (L/M)	Wetted Width at 80% (Mtr)
4.4 – 10.9	848 – 1988	70 – 106

Description	Code	Price
GT070B 125mm x 400m	GT070B125400	121,701.00

Machine Options	Code	Price
Emptying Compressor	75430550	4,250.90

Controller Options	Code	Price
Ma-Rain 56 Kit	35510120SKIT	7,391.80
No Computer	DED35462700KIT	POA
Digital 4.0 Router option for Ma-Rain 56	35400262	10,426.50
Wireless Measuring System for Ma-Rain 56 computer	35400350SKIT	1,803.50

Sprinkler Upgrade Options	Code	Price
SIME Gemini 25° 2 Speed	RGUPEXP-GEM2S	720.80
Nelson SR200 Gun	RGUPEXP-SR200K	5,706.00
Komet 160 Ultra Kit	RGUPEXP-K160U	-30.80

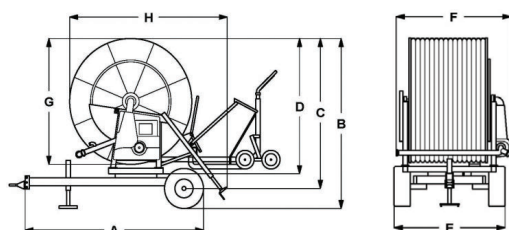

WEIGHTS AND DIMENSIONS

SIZE (cm)							
A	B	C	D	E	F	G	H
375	385	345	325	243	235	309	360

Dry Weight 3650 kg

* Please note dimensions and weights are to be used as a guide only.

MARANI HARD HOSE IRRIGATORS



GTS080B

125mm x 450m

Item Code: GTS080B125450

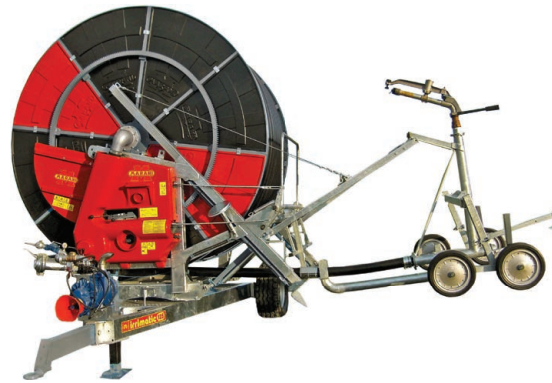

STANDARD EQUIPMENT

- Ma-Rain 26 Kit c/w solar panel and pressure switch
- SIME Explorer Big Gun 25° and nozzles
- Telescopic hydraulic feet
- Pressure gauge (glycerine bath)
- Stabilizers on drawbar
- Winding handle
- Hot galvanized chassis and reel
- Safety guards
- Water Inlet Shut-Off Valve
- PTO
- Flexible connection pipe with storage reel
- Galvanized raingun trolley mounted on variable track hard rubber wheels
- Turbine mounted on the gearbox with built-in bypass
- 4 Speed gearbox with synchronised speeds
- 4 Wheel chassis
- 5 Wheel trolley
- Water filter
- Hydraulic lifting of trolley
- Hydraulic rotation of turntable
- Hydraulic lifting of drawbar

TECHNICAL DATA

Pressure at Inlet (BAR)	Flow Rate (L/M)	Wetted Width at 80% (Mtr)
4.6 – 11.0	848 – 1901	70 – 102

Description	Code	Price
GTS080B 125mm x 450m	GTS080B125450	122,085.20

Machine Options	Code	Price
Emptying Compressor	75430550	4,250.90

Controller Options	Code	Price
Ma-Rain 56 Kit	35510120SKIT	7,391.80
No Computer	DED35462700KIT	POA
Digital 4.0 Router option for Ma-Rain 56	35400262	10,426.50
Wireless Measuring System for Ma-Rain 56 computer	35400350SKIT	1,803.50

Sprinkler Upgrade Options	Code	Price
SIME Gemini 25° 2 Speed	RGUPEXP-GEM2S	720.80
Nelson SR200 Gun	RGUPEXP-SR200K	5,706.00
Komet 202 Ultra	RGUPEXP-K202U	205.60

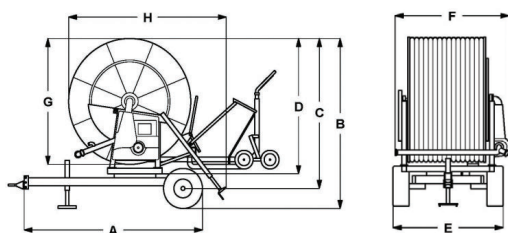

WEIGHTS AND DIMENSIONS

SIZE (cm)							
A	B	C	D	E	F	G	H
364	400	358	340	235	243	309	350

Dry Weight 4775 kg

* Please note dimensions and weights are to be used as a guide only.

MARANI HARD HOSE IRRIGATORS



MARANI HARD HOSE IRRIGATORS

MARANI HARD HOSE IRRIGATORS

GTS080B

125mm x 500m

Item Code: GTS080B125500

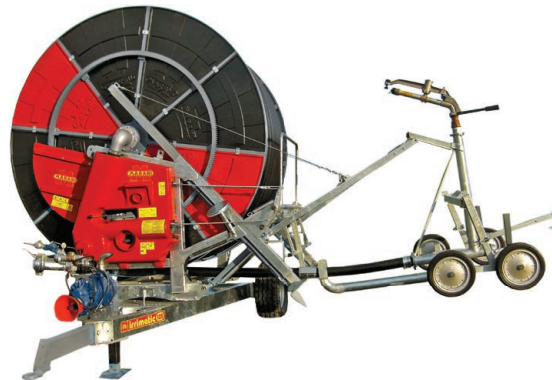

STANDARD EQUIPMENT

- Ma-Rain 26 Kit c/w solar panel and pressure switch
- SIME Explorer Big Gun 25° and nozzles
- Telescopic hydraulic feet
- Pressure gauge (glycerine bath)
- Stabilizers on drawbar
- Winding handle
- Hot galvanized chassis and reel
- Safety guards
- Water Inlet Shut-Off Valve
- PTO
- Flexible connection pipe with storage reel
- Galvanized raingun trolley mounted on variable track hard rubber wheels
- Turbine mounted on the gearbox with built-in bypass
- 4 Speed gearbox with synchronised speeds
- 4 Wheel chassis
- 5 Wheel trolley
- Water filter
- Hydraulic lifting of trolley
- Hydraulic rotation of turntable
- Hydraulic lifting of drawbar

TECHNICAL DATA

Pressure at Inlet (BAR)	Flow Rate (L/M)	Wetted Width at 80% (Mtr)
4.7 – 11.4	848 – 1774	70 – 102

Description	Code	Price
GTS080B 125mm x 500m	GTS080B125500	124,034.50

Machine Options	Code	Price
Emptying Compressor	75430550	4,250.90

Controller Options	Code	Price
Ma-Rain 56 Kit	35510120SKIT	7,391.80
No Computer	DED35462700KIT	POA
Digital 4.0 Router option for Ma-Rain 56	35400262	10,426.50
Wireless Measuring System for Ma-Rain 56 computer	35400350SKIT	1,803.50

Sprinkler Upgrade Options	Code	Price
SIME Gemini 25° 2 Speed	RGUPEXP-GEM2S	720.80
Nelson SR200 Gun	RGUPEXP-SR200K	5,706.00
Komet 202 Ultra	RGUPEXP-K202U	205.60

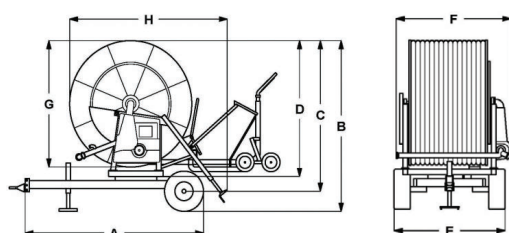

WEIGHTS AND DIMENSIONS

SIZE (cm)							
A	B	C	D	E	F	G	H
364	400	358	340	235	243	309	350

Dry Weight 4775 kg

* Please note dimensions and weights are to be used as a guide only.

MARANI HARD HOSE IRRIGATORS



GTS080B

140mm x 380m

Item Code: GTS080B140380



STANDARD EQUIPMENT

- Ma-Rain 26 Kit c/w solar panel and pressure switch
- SIME Explorer Big Gun 25° and nozzles
- Telescopic hydraulic feet
- Pressure gauge (glycerine bath)
- Stabilizers on drawbar
- Winding handle
- Hot galvanized chassis and reel
- Safety guards
- Water Inlet Shut-Off Valve
- PTO
- Flexible connection pipe with storage reel
- Galvanized raingun trolley mounted on variable track hard rubber wheels
- Turbine mounted on the gearbox with built-in bypass
- 4 Speed gearbox with synchronised speeds
- 4 Wheel chassis
- 5 Wheel trolley
- Water filter
- Hydraulic lifting of trolley
- Hydraulic rotation of turntable
- Hydraulic lifting of drawbar

TECHNICAL DATA

Pressure at Inlet (BAR)	Flow Rate (L/M)	Wetted Width at 80% (Mtr)
4.1 – 11.2	974 – 2648	77 – 117

Description	Code	Price
GTS080B 140mm x 380m	GTS080B140380	155,940.00

Machine Options	Code	Price
Emptying Compressor	75430550	4,250.90

Controller Options	Code	Price
Ma-Rain 56 Kit	35510120SKIT	7,391.80
No Computer	DED35462700KIT	POA
Digital 4.0 Router option for Ma-Rain 56	35400262	10,426.50
Wireless Measuring System for Ma-Rain 56 computer	35400350SKIT	1,803.50

Sprinkler Upgrade Options	Code	Price
SIME Gemini 25° 2 Speed	RGUPEXP-GEM2S	720.80
Nelson SR200 Gun	RGUPEXP-SR200K	5,706.00
Komet 202 Ultra	RGUPEXP-K202U	205.60

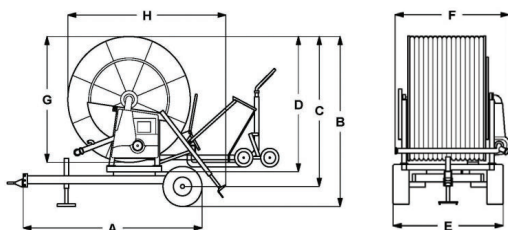

WEIGHTS AND DIMENSIONS

SIZE (cm)							
A	B	C	D	E	F	G	H
364	400	358	340	235	243	309	350

Dry Weight 4775 kg

* Please note dimensions and weights are to be used as a guide only.



MARANI HARD HOSE IRRIGATORS

MARANI HARD HOSE IRRIGATORS

GTS080C

140mm x 400m

Item Code: GTS080C140400



STANDARD EQUIPMENT

- Ma-Rain 26 Kit c/w solar panel and pressure switch
- SIME Explorer Big Gun 25° and nozzles
- Telescopic hydraulic feet
- Pressure gauge (glycerine bath)
- Stabilizers on drawbar
- Winding handle
- Hot galvanized chassis and reel
- Safety guards
- Water Inlet Shut-Off Valve
- PTO
- Flexible connection pipe with storage reel
- Galvanized raingun trolley mounted on variable track hard rubber wheels
- Turbine mounted on the gearbox with built-in bypass
- 4 Speed gearbox with synchronised speeds
- 4 Wheel chassis
- 5 Wheel trolley
- Water filter
- Hydraulic lifting of trolley
- Hydraulic rotation of turntable
- Hydraulic lifting of drawbar

TECHNICAL DATA

Pressure at Inlet (BAR)	Flow Rate (L/M)	Wetted Width at 80% (Mtr)
4.2 - 12.0	974 - 2648	77 - 117

Description	Code	Price
GTS080C 140mm x 400m	GTS080C140400	131,012.20

Machine Options	Code	Price
Emptying Compressor	75430550	4,250.90

Controller Options	Code	Price
No on board computer	DED35462700KIT	POA
Ma-Rain 56 Kit	35510120SKIT	7,391.80
Digital 4.0 Router option for Ma-Rain 56	35400262	10,426.50
Wireless Measuring System for Ma-Rain 56 computer	35400350SKIT	1,803.50

Sprinkler Upgrade Options	Code	Price
SIME Gemini 25° 2 Speed	RGUPEXP-GEM2S	720.80
Nelson SR200 Gun	RGUPEXP-SR200K	5,706.00
Komet 202 Ultra	RGUPEXP-K202U	205.60

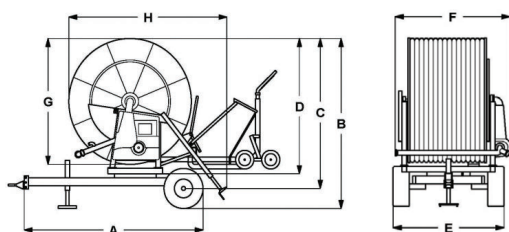

WEIGHTS AND DIMENSIONS

SIZE (cm)							
A	B	C	D	E	F	G	H
364	400	358	340	235	243	309	350

Dry Weight 4775 kg

* Please note dimensions and weights are to be used as a guide only.

MARANI HARD HOSE IRRIGATORS



GTS080C

140mm x 450m

Item Code: GTS080C140450

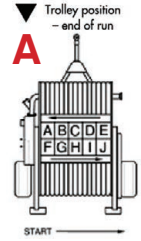
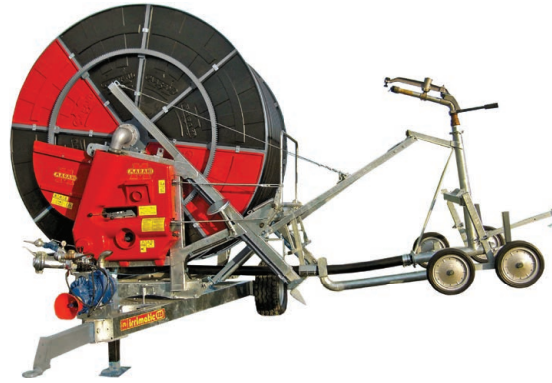

STANDARD EQUIPMENT

- Ma-Rain 26 Kit c/w solar panel and pressure switch
- SIME Explorer Big Gun 25° and nozzles
- Telescopic hydraulic feet
- Pressure gauge (glycerine bath)
- Stabilizers on drawbar
- Winding handle
- Hot galvanized chassis and reel
- Safety guards
- Water Inlet Shut-Off Valve
- PTO
- Flexible connection pipe with storage reel
- Galvanized raingun trolley mounted on variable track hard rubber wheels
- Turbine mounted on the gearbox with built-in bypass
- 4 Speed gearbox with synchronised speeds
- 4 Wheel chassis
- 5 Wheel trolley
- Water filter
- Hydraulic lifting of trolley
- Hydraulic rotation of turntable
- Hydraulic lifting of drawbar

TECHNICAL DATA

Pressure at Inlet (BAR)	Flow Rate (L/M)	Wetted Width at 80% (Mtr)
4.3 - 10.9	874 - 2455	77 - 110

Description	Code	Price
GTS080C 140mm x 450m	GTS080C140450	132,803.30

Machine Options	Code	Price
Emptying Compressor	75430550	4,250.90

Controller Options	Code	Price
No on board computer	DED35462700KIT	POA
Ma-Rain 56 Kit	35510120SKIT	7,391.80
Digital 4.0 Router option for Ma-Rain 56	35400262	10,426.50
Wireless Measuring System for Ma-Rain 56 computer	35400350SKIT	1,803.50

Sprinkler Upgrade Options	Code	Price
SIME Gemini 25° 2 Speed	RGUPEXP-GEM2S	720.80
Nelson SR200 Gun	RGUPEXP-SR200K	5,706.00
Komet 202 Ultra	RGUPEXP-K202U	205.60

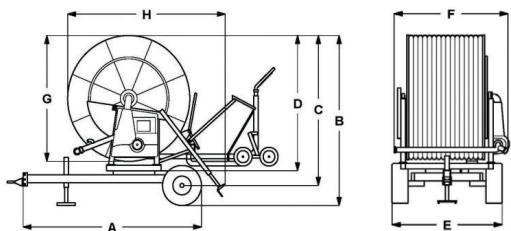

WEIGHTS AND DIMENSIONS

SIZE (cm)							
A	B	C	D	E	F	G	H
364	400	358	340	235	243	309	350

Dry Weight 4775 kg

* Please note dimensions and weights are to be used as a guide only.

MARANI HARD HOSE IRRIGATORS



MARANI HARD HOSE IRRIGATORS

GTS090C

140mm x 500m

Item Code: GTS090C140500

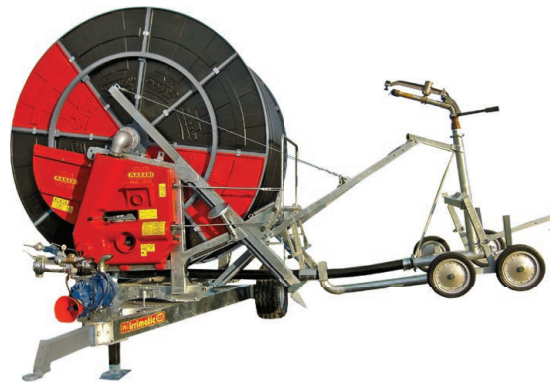

STANDARD EQUIPMENT

- Ma-Rain 56 Kit c/w solar panel and pressure switch
- SIME Explorer Big Gun 25° and nozzles
- 4 wheel chassis
- Flexible connection pipe
- Computer Ma-Rain 56
- Hydraulic lifting device of trolley
- PTO
- Hose retraction by double chain
- Hydraulic rotation of turntable
- Water Inlet Shut-Off valve
- Hot galvanized chassis and reel
- Hydraulic system by rapid couplings to tractor with storage reel
- 5 Wheel trolley with variable track hard rubber wheels
- Turbine mounted on the gearbox with built-in bypass
- Telescopic hydraulic feet
- Pressure gauge (glycerine bath)
- Winding handle
- Hydraulic lifting of drawbar
- Safety guards made of steel swaged galvanised and painted
- 4 Speed gearbox with synchronised speeds
- Electric shut off valve
- Pressure Switch
- Emptying Compressor
- Water filter

TECHNICAL DATA

Pressure at Inlet (BAR)	Flow Rate (L/M)	Wetted Width at 80% (Mtr)
4.4 – 11.5	974 – 2455	77 – 110

Description	Code	Price
GTS090C 140mm x 500m	GTS090C140500	166,827.50

Controller Options	Code	Price
Digital 4.0 Router option for Ma-Rain 56	35400262	10,426.50
Wireless Measuring System for Ma-Rain 56 computer	35400350SKIT	1,803.50

Sprinkler Upgrade Options	Code	Price
SIME Gemini 25° 2 Speed	RGUPEXP-GEM2S	720.80
Nelson SR200 Gun	RGUPEXP-SR200K	5,706.00
Komet 202 Ultra	RGUPEXP-K202U	205.60

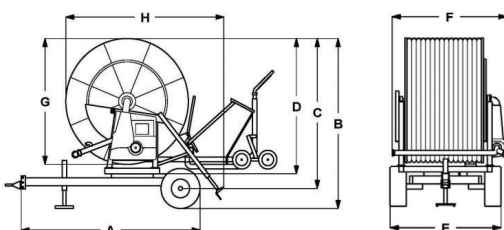

WEIGHTS AND DIMENSIONS

SIZE (cm)							
A	B	C	D	E	F	G	H
440	451	416	376	255	243	334	440

Dry Weight 6179 kg

* Please note dimensions and weights are to be used as a guide only.

MARANI HARD HOSE IRRIGATORS



Rodney Industries

Proud to be your

PARTNER IN IRRIGATION



With a range that expands over 40 machines from 40mm to 140mm, you are sure to find the Marani Hard Hose to suit your requirements. Talk to us today!

RODNEY INDUSTRIES

Phone: 07 3624 0300
Email: sales@rodneyind.com.au
Web: www.rodneyind.com.au





MARANI HARD HOSE IRRIGATORS

MARANI HARD HOSE IRRIGATORS

IT050B

110mm x 300m

Item Code: IT050B110300



STANDARD EQUIPMENT

- Ma-Rain 26 Kit c/w solar panel and pressure switch
- SIME Reflex gun and nozzles
- Hydraulic lifting device of trolley
- 4 Speed gearbox
- Water Inlet Shut-Off Valve
- Hydraulic rotation of turntable
- PTO
- Pressure gauge (glycerine bath)
- Hydraulic feet
- Flexible connection pipe
- Hydraulic lift of drawbar
- Hot galvanized chassis and reel
- Speed equalizer
- Winding handle
- Safety guards
- 5 Wheel trolley
- Hydraulic system by rapid couplings to tractor with storage reel
- Galvanized 5 wheel raingun trolley mounted on variable track hard rubber wheels
- Turbine mounted on the gearbox with built-in bypass
- Water filter

TECHNICAL DATA

Pressure at Inlet (BAR)	Flow Rate (L/M)	Wetted Width at 80% (Mtr)
4.4 – 10.5	732 – 1570	66 – 94

Description	Code	Price
IT050B 110mm x 300m	IT050B110300	98,875.00

Machine Options	Code	Price
Emptying Compressor	75430550	4,250.90

Controller Options	Code	Price
No on board computer	DED35462700KIT	POA
Ma-Rain 56 Kit	35510120SKIT	7,391.80
Digital 4.0 Router option for Ma-Rain 56	35400262	10,426.50
Wireless Measuring System for Ma-Rain 56 computer	35400350SKIT	1,803.50

Sprinkler Upgrade Options	Code	Price
SIME Mariner 25° 2 Speed	RGUPREF-MAR2S	679.50
Nelson SR150 Gun	RGUPREF-SR150K	2,976.50
Komet 160 Ultra Kit	RGUPREF-K160U	213.10

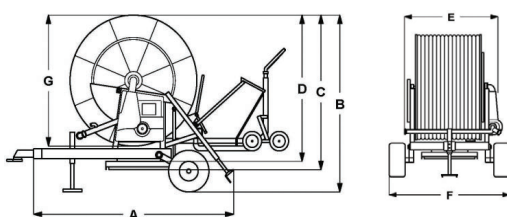

WEIGHTS AND DIMENSIONS

SIZE (cm)						
A	B	C	D	E	F	G
338	338	310	290	220	255	268

Dry Weight 2895 kg

* Please note dimensions and weights are to be used as a guide only.

MARANI HARD HOSE IRRIGATORS



MARANI HARD HOSE IRRIGATORS

IT050B

110mm x 350m

Item Code: IT050B110350



STANDARD EQUIPMENT

- Ma-Rain 26 Kit c/w solar panel and pressure switch
- SIME Reflex gun and nozzles
- Hydraulic lifting device of trolley
- 4 Speed gearbox
- Water Inlet Shut-Off Valve
- Hydraulic rotation of turntable
- PTO
- Pressure gauge (glycerine bath)
- Hydraulic feet
- Flexible connection pipe
- Hydraulic lift of drawbar
- Hot galvanized chassis and reel
- Speed equalizer
- Winding handle
- Safety guards
- 5 Wheel trolley
- Hydraulic system by rapid couplings to tractor with storage reel
- Galvanized 5 wheel raingun trolley mounted on variable track hard rubber wheels
- Turbine mounted on the gearbox with built-in bypass
- Water filter

TECHNICAL DATA

Pressure at Inlet (BAR)	Flow Rate (L/M)	Wetted Width at 80% (Mtr)
4.3 – 11.2	623 – 1570	62 – 94

Description	Code	Price
IT050B 110mm x 350m	IT050B110350	87,704.90

Machine Options	Code	Price
Emptying Compressor	75430550	4,250.90

Controller Options	Code	Price
No on board computer	DED35462700KIT	POA
Ma-Rain 56 Kit	35510120SKIT	7,391.80
Digital 4.0 Router option for Ma-Rain 56	35400262	10,426.50
Wireless Measuring System for Ma-Rain 56 computer	35400350SKIT	1,803.50

Sprinkler Upgrade Options	Code	Price
SIME Mariner 25° 2 Speed	RGUPREF-MAR2S	679.50
Nelson SR150 Gun	RGUPREF-SR150K	2,976.50
Komet 160 Ultra Kit	RGUPREF-K160U	213.10

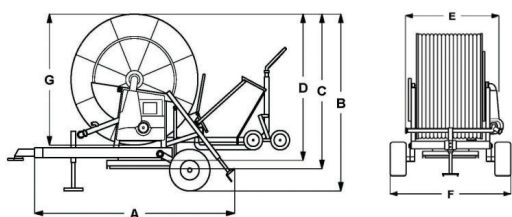

WEIGHTS AND DIMENSIONS

SIZE (cm)						
A	B	C	D	E	F	G
338	338	310	290	220	255	268

Dry Weight 2895 kg

* Please note dimensions and weights are to be used as a guide only.



MARANI HARD HOSE IRRIGATORS

MARANI HARD HOSE IRRIGATORS

IT060B

110mm x 420m

Item Code: IT060B110400

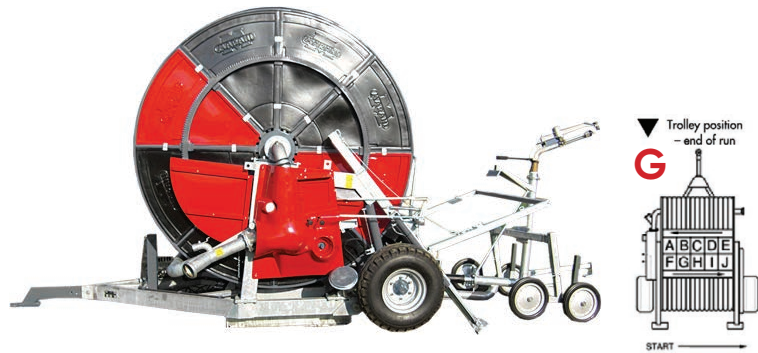

STANDARD EQUIPMENT

- Ma-Rain 26 Kit c/w solar panel and pressure switch
- SIME Reflex gun and nozzles
- Hydraulic lifting device of trolley
- 4 Speed gearbox
- Water Inlet Shut-Off Valve
- Hydraulic rotation of turntable
- PTO
- Pressure gauge (glycerine bath)
- Hydraulic feet
- Flexible connection pipe
- Hydraulic lift of drawbar
- Hot galvanized chassis and reel
- Winding handle
- Safety guards
- 5 Wheel trolley
- Hydraulic system by rapid couplings to tractor with storage reel
- Galvanized 5 wheel raingun trolley mounted on variable track hard rubber wheels
- Turbine mounted on the gearbox with built-in bypass
- Water filter

TECHNICAL DATA

Pressure at Inlet (BAR)	Flow Rate (L/M)	Wetted Width at 80% (Mtr)
4.5 – 11.3	623 – 1501	62 – 92

Description	Code	Price
IT060B 110mm x 420m	IT060B110420	103,795.80

Machine Options	Code	Price
Emptying Compressor	75430550	4,250.90

Controller Options	Code	Price
No on board computer	DED35462700KIT	POA
Ma-Rain 56 Kit	35510120SKIT	7,391.80
Digital 4.0 Router option for Ma-Rain 56	35400262	10,426.50
Wireless Measuring System for Ma-Rain 56 computer	35400350SKIT	1,803.50

Sprinkler Upgrade Options	Code	Price
SIME Mariner Big Gun	RGUPREF-MAR	412.30
SIME Mariner 2 Speed	RGUPREF-MAR2S	679.50
Nelson SR150 Gun	RGUPREF-SR150K	2,976.50
Komet 160 Ultra Kit	RGUPREF-K160U	213.10

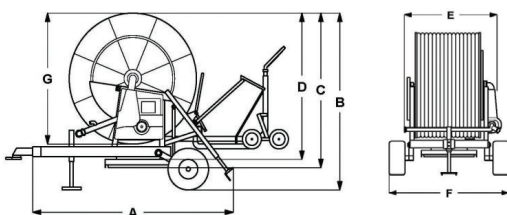

WEIGHTS AND DIMENSIONS

SIZE (cm)						
A	B	C	D	E	F	G
400	336	330	303	252	283	280

Dry Weight 3350 kg

* Please note dimensions and weights are to be used as a guide only.

MARANI HARD HOSE IRRIGATORS



MARANI HARD HOSE IRRIGATORS

IT060B

110mm x 450m

Item Code: IT060B110450



STANDARD EQUIPMENT

- Ma-Rain 26 Kit c/w solar panel and pressure switch
- SIME Reflex gun and nozzles
- Hydraulic lifting device of trolley
- 4 Speed gearbox
- Water Inlet Shut-Off Valve
- Hydraulic rotation of turntable
- PTO
- Pressure gauge (glycerine bath)
- Hydraulic feet
- Flexible connection pipe
- Hydraulic lift of drawbar
- Hot galvanized chassis and reel
- Winding handle
- Safety guards
- 5 Wheel trolley
- Hydraulic system by rapid couplings to tractor with storage reel
- Galvanized 5 wheel raingun trolley mounted on variable track hard rubber wheels
- Turbine mounted on the gearbox with built-in bypass
- Water filter

TECHNICAL DATA

Pressure at Inlet (BAR)	Flow Rate (L/M)	Wetted Width at 80% (Mtr)
4.5 – 11.3	623 – 1501	62 – 92

Description	Code	Price
IT060B 110mm x 450m	IT060B110450	97,298.60

Machine Options	Code	Price
Emptying Compressor	75430550	4,250.90

Controller Options	Code	Price
No on board computer	DED35462700KIT	POA
Ma-Rain 56 Kit	35510120SKIT	7,391.80
Digital 4.0 Router option for Ma-Rain 56	35400262	10,426.50
Wireless Measuring System for Ma-Rain 56 computer	35400350SKIT	1,803.50

Sprinkler Upgrade Options	Code	Price
SIME Mariner Big Gun	RGUPREF-MAR	412.30
SIME Mariner 2 Speed	RGUPREF-MAR2S	679.50
Nelson SR150 Gun	RGUPREF-SR150K	2,976.50
Komet 160 Ultra Kit	RGUPREF-K160U	213.10

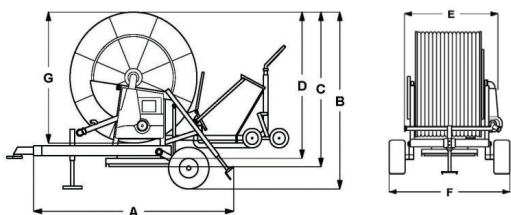

WEIGHTS AND DIMENSIONS

SIZE (cm)						
A	B	C	D	E	F	G
400	336	330	303	252	283	280

Dry Weight 3350 kg

* Please note dimensions and weights are to be used as a guide only.



MARANI HARD HOSE IRRIGATORS

MARANI HARD HOSE IRRIGATORS

IT060B

125mm x 300m

Item Code: IT060B125300



STANDARD EQUIPMENT

- Ma-Rain 26 Kit c/w solar panel and pressure switch
- SIME Explorer and nozzles
- Hydraulic lifting device of trolley
- 4 Speed gearbox
- Water Inlet Shut-Off Valve
- Hydraulic rotation of turntable
- PTO
- Pressure gauge (glycerine bath)
- Hydraulic feet
- Flexible connection pipe
- Hydraulic lift of drawbar
- Hot galvanized chassis and reel
- Winding handle
- Safety guards
- 5 Wheel trolley
- Hydraulic system by rapid couplings to tractor with storage reel
- Galvanized 5 wheel raingun trolley mounted on variable track hard rubber wheels
- Turbine mounted on the gearbox with built-in bypass
- Water filter

TECHNICAL DATA

Pressure at Inlet (BAR)	Flow Rate (L/M)	Wetted Width at 80% (Mtr)
4.1 – 11.3	848 – 2144	70 – 112

Description	Code	Price
IT060B 125mm x 300m	IT060B125300	112,435.00

Machine Options	Code	Price
Emptying Compressor	75430550	4,250.90

Controller Options	Code	Price
No on board computer	DED35462700KIT	POA
Ma-Rain 56 Kit	35510120SKIT	7,391.80
Digital 4.0 Router option for Ma-Rain 56	35400262	10,426.50
Wireless Measuring System for Ma-Rain 56 computer	35400350SKIT	1,803.50

Sprinkler Upgrade Options	Code	Price
SIME Gemini 25° 2 Speed	RGUPEXP-GEM2S	720.80
Nelson SR200 Gun	RGUPEXP-SR200K	5,706.00
Komet 202 Ultra	RGUPEXP-K202U	205.60

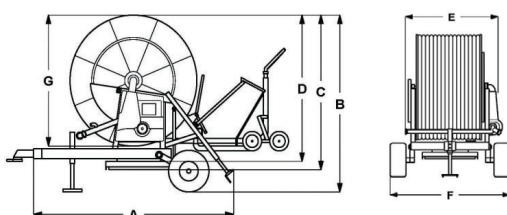

WEIGHTS AND DIMENSIONS

SIZE (cm)						
A	B	C	D	E	F	G
400	336	330	303	252	283	280

Dry Weight 3350 kg

* Please note dimensions and weights are to be used as a guide only.

MARANI HARD HOSE IRRIGATORS



MARANI HARD HOSE IRRIGATORS

IT060B

125mm x 350m

Item Code: IT060B125350



STANDARD EQUIPMENT

- Ma-Rain 26 Kit c/w solar panel and pressure switch
- SIME Explorer and nozzles
- Hydraulic lifting device of trolley
- 4 Speed gearbox
- Water Inlet Shut-Off Valve
- Hydraulic rotation of turntable
- PTO
- Pressure gauge (glycerine bath)
- Hydraulic feet
- Flexible connection pipe
- Hydraulic lift of drawbar
- Hot galvanized chassis and reel
- Winding handle
- Safety guards
- 5 Wheel trolley
- Hydraulic system by rapid couplings to tractor with storage reel
- Galvanized 5 wheel raingun trolley mounted on variable track hard rubber wheels
- Turbine mounted on the gearbox with built-in bypass
- Water filter

TECHNICAL DATA

Pressure at Inlet (BAR)	Flow Rate (L/M)	Wetted Width at 80% (Mtr)
4.3 – 11.2	848 – 1913	70 – 109

Description	Code	Price
IT060B 125mm x 350m	IT060B125350	98,739.40

Machine Options	Code	Price
Emptying Compressor	75430550	4,250.90

Controller Options	Code	Price
No on board computer	DED35462700KIT	POA
Ma-Rain 56 Kit	35510120SKIT	7,391.80
Digital 4.0 Router option for Ma-Rain 56	35400262	10,426.50
Wireless Measuring System for Ma-Rain 56 computer	35400350SKIT	1,803.50

Sprinkler Upgrade Options	Code	Price
SIME Gemini 25° 2 Speed	RGUPEXP-GEM2S	720.80
Nelson SR200 Gun	RGUPEXP-SR200K	5,706.00
Komet 202 Ultra	RGUPEXP-K202U	205.60

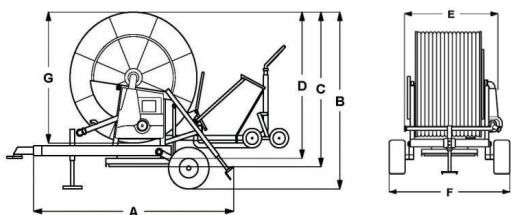

WEIGHTS AND DIMENSIONS

SIZE (cm)						
A	B	C	D	E	F	G
400	336	330	303	252	283	280

Dry Weight 3350 kg

* Please note dimensions and weights are to be used as a guide only.



MARANI HARD HOSE IRRIGATORS

MARANI HARD HOSE IRRIGATORS

IT070B

125mm x 400m

Item Code: IT070B125400-4W



STANDARD EQUIPMENT

- Ma-Rain 26 Kit c/w solar panel and pressure switch
- SIME Explorer and nozzles
- 4 Wheel chassis upgrade
- Hydraulic lifting device of trolley
- PTO
- Winding handle
- Hydraulic rotation of turntable
- Hot galvanized chassis and reel
- Pressure gauge (glycerine bath)
- Hydraulic feet
- Safety guards
- Water Inlet Shut-Off Valve
- Hydraulic lift of drawbar
- Hydraulic system by rapid couplings to tractor
- Turbine mounted on the gearbox with built-in bypass
- Flexible connection pipe with storage reel
- 4 Speed gearbox
- Galvanized 5 wheel raingun trolley mounted on variable hard rubber wheels
- 4 wheel chassis kit
- Water filter

TECHNICAL DATA

Pressure at Inlet (BAR)	Flow Rate (L/M)	Wetted Width at 80% (Mtr)
4.4 – 10.9	848 – 1988	70 – 106

Description	Code	Price
IT070B 125mm x 400m	IT070B125400-4W	121,500.60

Machine Options	Code	Price
Emptying Compressor	75430550	4,250.90

Controller Options	Code	Price
No on board computer	DED35462700KIT	POA
Ma-Rain 56 Kit	35510120SKIT	7,391.80
Digital 4.0 Router option for Ma-Rain 56	35400262	10,426.50
Wireless Measuring System for Ma-Rain 56 computer	35400350SKIT	1,803.50

Sprinkler Upgrade Options	Code	Price
SIME Gemini 25° 2 Speed	RGUPEXP-GEM2S	720.80
Nelson SR200 Gun	RGUPEXP-SR200K	5,706.00
Komet 202 Ultra Kit	RGUPEXP-K202U	205.60

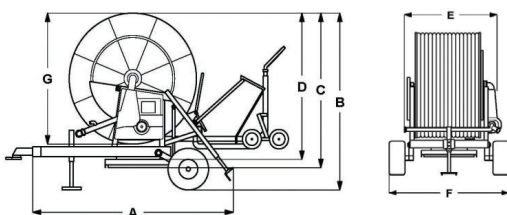

WEIGHTS AND DIMENSIONS

SIZE (cm)						
A	B	C	D	E	F	G
400	383	355	330	240	274	309

Dry Weight 3850 kg

* Please note dimensions and weights are to be used as a guide only.

MARANI HARD HOSE IRRIGATORS



MARANI HARD HOSE IRRIGATORS

ITS080B

110mm x 600m

Item Code: ITS080B110600

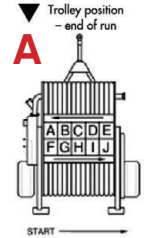

STANDARD EQUIPMENT

- Ma-Rain 26 Kit c/w solar panel and pressure switch
- SIME Reflex gun and nozzles
- Hydraulic lifting device of trolley
- PTO
- Winding handle
- Hydraulic rotation of turntable
- Hot galvanized chassis and reel
- Pressure gauge (glycerine bath)
- Hydraulic feet
- Safety guards
- Water Inlet Shut-Off Valve
- Hydraulic lift of drawbar
- Hydraulic system by rapid couplings to tractor
- Turbine mounted on the gearbox with built-in bypass
- Flexible connection pipe with storage reel
- 4 Speed gearbox
- Galvanized 5 wheel raingun trolley mounted on variable hard rubber wheels
- Four wheel chassis kit as standard
- Water filter

TECHNICAL DATA

Pressure at Inlet (BAR)	Flow Rate (L/M)	Wetted Width at 80% (Mtr)
4.8 – 11.5	522 – 1149	59 – 86

Description	Code	Price
ITS080B 110mm x 600m	ITS080B110600	155,375.00

Machine Options	Code	Price
Emptying Compressor	81670000	4,606.10

Controller Options	Code	Price
No on board computer	DED35462700KIT	POA
Ma-Rain 56 Kit	35510120SKIT	7,391.80
Digital 4.0 Router option for Ma-Rain 56	35400262	10,426.50
Wireless Measuring System for Ma-Rain 56 computer	35400350SKIT	1,803.50

Sprinkler Upgrade Options	Code	Price
SIME Mariner 25° 2 Speed	RGUPREF-MAR2S	679.50
Nelson SR150 Gun	RGUPREF-SR150K	2,976.50
Komet 160 Ultra Kit	RGUPREF-K160U	213.10

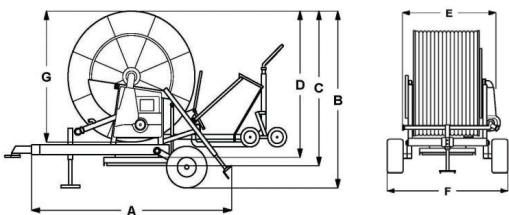

WEIGHTS AND DIMENSIONS

SIZE (cm)						
A	B	C	D	E	F	G
410	395	365	348	249	282	309

Dry Weight 5349 kg

* Please note dimensions and weights are to be used as a guide only.



MARANI HARD HOSE IRRIGATORS

MARANI HARD HOSE IRRIGATORS

ITS080B

125mm x 450m

Item Code: ITS080B125450



STANDARD EQUIPMENT

- Ma-Rain 26 Kit c/w solar panel and pressure switch
- SIME Explorer gun and nozzles
- Hydraulic lifting device of trolley
- PTO
- Winding handle
- Hydraulic rotation of turntable
- Hot galvanized chassis and reel
- Pressure gauge (glycerine bath)
- Hydraulic feet
- Safety guards
- Water Inlet Shut-Off Valve
- Hydraulic lift of drawbar
- Hydraulic system by rapid couplings to tractor
- Turbine mounted on the gearbox with built-in bypass
- Flexible connection pipe with storage reel
- 4 Speed gearbox
- Galvanized 5 wheel raingun trolley mounted on variable hard rubber wheels
- Four wheel chassis kit as standard
- Water filter

TECHNICAL DATA

Pressure at Inlet (BAR)	Flow Rate (L/M)	Wetted Width at 80% (Mtr)
4.6 – 11.0	848 – 1901	70 – 102

Description	Code	Price
ITS080B 125mm x 450m	ITS080B125450	133,526.50

Machine Options	Code	Price
Emptying Compressor	81670000	4,606.10

Controller Options	Code	Price
No on board computer	DED35462700KIT	POA
Ma-Rain 56 Kit	35510120SKIT	7,391.80
Digital 4.0 Router option for Ma-Rain 56	35400262	10,426.50
Wireless Measuring System for Ma-Rain 56 computer	35400350SKIT	1,803.50

Sprinkler Upgrade Options	Code	Price
SIME Gemini 25° 2 Speed	RGUPEXP-GEM2S	720.80
Nelson SR200 Gun	RGUPEXP-SR200K	5,706.00
Komet 202 Ultra Kit	RGUPEXP-K202U	205.60

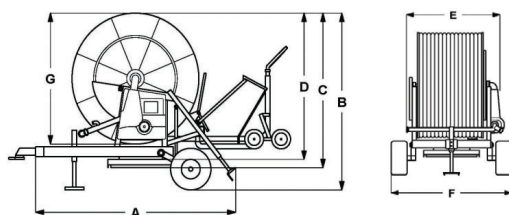

WEIGHTS AND DIMENSIONS

SIZE (cm)						
A	B	C	D	E	F	G
410	395	365	348	249	282	309

Dry Weight 5349 kg

* Please note dimensions and weights are to be used as a guide only.

MARANI HARD HOSE IRRIGATORS



MARANI HARD HOSE IRRIGATORS

ITS080B

125mm x 500m

Item Code: ITS080B125500



STANDARD EQUIPMENT

- Ma-Rain 26 Kit c/w solar panel and pressure switch
- SIME Explorer gun and nozzles
- Hydraulic lifting device of trolley
- PTO
- Winding handle
- Hydraulic rotation of turntable
- Hot galvanized chassis and reel
- Pressure gauge (glycerine bath)
- Hydraulic feet
- Safety guards
- Water Inlet Shut-Off Valve
- Hydraulic lift of drawbar
- Hydraulic system by rapid couplings to tractor
- Turbine mounted on the gearbox with built-in bypass
- Flexible connection pipe with storage reel
- 4 Speed gearbox
- Galvanized 5 wheel raingun trolley mounted on variable hard rubber wheels
- Four wheel chassis kit as standard
- Water filter

TECHNICAL DATA

Pressure at Inlet (BAR)	Flow Rate (L/M)	Wetted Width at 80% (Mtr)
4.7 – 11.4	848 – 1774	70 – 102

Description	Code	Price
ITS080B 125mm x 500m	ITS080B125500	160,460.00

Machine Options	Code	Price
Emptying Compressor	81670000	4,606.10

Controller Options	Code	Price
No on board computer	DED35462700KIT	POA
Ma-Rain 56 Kit	35510120SKIT	7,391.80
Digital 4.0 Router option for Ma-Rain 56	35400262	10,426.50
Wireless Measuring System for Ma-Rain 56 computer	35400350SKIT	1,803.50

Sprinkler Upgrade Options	Code	Price
SIME Gemini 25° 2 Speed	RGUPEXP-GEM2S	720.80
Nelson SR200 Gun	RGUPEXP-SR200K	5,706.00
Komet 202 Ultra Kit	RGUPEXP-K202U	205.60

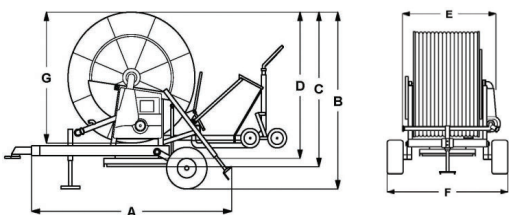

WEIGHTS AND DIMENSIONS

SIZE (cm)						
A	B	C	D	E	F	G
410	395	365	348	249	282	309

Dry Weight 5349 kg

* Please note dimensions and weights are to be used as a guide only.



MARANI HARD HOSE IRRIGATORS

MARANI HARD HOSE IRRIGATORS

ITS080C

140mm x 410m

Item Code: ITS080C140410



STANDARD EQUIPMENT

- Ma-Rain 26 Kit c/w solar panel and pressure switch
- SIME Explorer and nozzles
- Hydraulic lifting device of trolley
- PTO
- Winding handle
- Hydraulic rotation of turntable
- Hot galvanized chassis and reel
- Pressure gauge (glycerine bath)
- Hydraulic feet
- Safety guards
- Water Inlet Shut-Off Valve
- Hydraulic lift of drawbar
- Hydraulic system by rapid couplings to tractor
- Turbine mounted on the gearbox with built-in bypass
- Flexible connection pipe with storage reel
- 4 Speed gearbox
- Galvanized 5 wheel raingun trolley mounted on variable hard rubber wheels
- Four wheel chassis kit as standard
- Water filter

TECHNICAL DATA

Pressure at Inlet (BAR)	Flow Rate (L/M)	Wetted Width at 80% (Mtr)
4.3 - 10.9	974 - 2455	77 - 110

Description	Code	Price
ITS080C 140mm x 410m	ITS080C140410	168,935.00

Machine Options	Code	Price
Emptying Compressor	81670000	4,606.10

Controller Options	Code	Price
No on board computer	DED35462700KIT	POA
Ma-Rain 56 Kit	35510120SKIT	7,391.80
Digital 4.0 Router option for Ma-Rain 56	35400262	10,426.50
Wireless Measuring System for Ma-Rain 56 computer	35400350SKIT	1,803.50

Sprinkler Upgrade Options	Code	Price
SIME Gemini 25° 2 Speed	RGUPEXP-GEM2S	720.80
Nelson SR200 Gun	RGUPEXP-SR200K	5,706.00
Komet 202 Ultra Kit	RGUPEXP-K202U	205.60

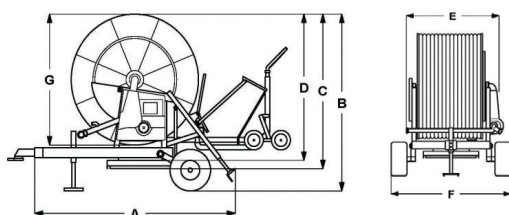

WEIGHTS AND DIMENSIONS

SIZE (cm)						
A	B	C	D	E	F	G
410	395	365	348	249	282	309

Dry Weight 5349 kg

* Please note dimensions and weights are to be used as a guide only.

MARANI HARD HOSE IRRIGATORS



MARANI HARD HOSE IRRIGATORS

ITS080C

140mm x 450m

Item Code: ITS080C140450



STANDARD EQUIPMENT

- Ma-Rain 26 Kit c/w solar panel and pressure switch
- SIME Explorer and nozzles
- Hydraulic lifting device of trolley
- PTO
- Winding handle
- Hydraulic rotation of turntable
- Hot galvanized chassis and reel
- Pressure gauge (glycerine bath)
- Hydraulic feet
- Safety guards
- Water Inlet Shut-Off Valve
- Hydraulic lift of drawbar
- Hydraulic system by rapid couplings to tractor
- Turbine mounted on the gearbox with built-in bypass
- Flexible connection pipe with storage reel
- 4 Speed gearbox
- Galvanized 5 wheel raingun trolley mounted on variable hard rubber wheels
- Four wheel chassis kit as standard
- Water filter

TECHNICAL DATA

Pressure at Inlet (BAR)	Flow Rate (L/M)	Wetted Width at 80% (Mtr)
4.3 - 10.9	974 - 2455	77 - 110

Description	Code	Price
ITS080C 140mm x 450m	ITS080C140450	157,448.50

Machine Options	Code	Price
Emptying Compressor	81670000	4,606.10

Controller Options	Code	Price
No on board computer	DED35462700KIT	POA
Ma-Rain 56 Kit	35510120SKIT	7,391.80
Digital 4.0 Router option for Ma-Rain 56	35400262	10,426.50
Wireless Measuring System for Ma-Rain 56 computer	35400350SKIT	1,803.50

Sprinkler Upgrade Options	Code	Price
SIME Gemini 25° 2 Speed	RGUPEXP-GEM2S	720.80
Nelson SR200 Gun	RGUPEXP-SR200K	5,706.00
Komet 202 Ultra Kit	RGUPEXP-K202U	205.60

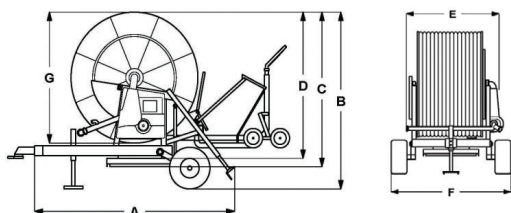

WEIGHTS AND DIMENSIONS

SIZE (cm)						
A	B	C	D	E	F	G
410	395	365	348	249	282	309

Dry Weight 5349 kg

* Please note dimensions and weights are to be used as a guide only.



MARANI HARD HOSE IRRIGATORS

ITS090C

140mm x 500m

Item Code: ITS090C140500



STANDARD EQUIPMENT

- Ma-Rain 56 Computer c/w solar panel and pressure switch
- SIME Explorer and nozzles
- Hydraulic lifting device of trolley
- PTO
- Winding handle
- Hydraulic rotation of turntable
- Hot galvanized chassis and reel
- Pressure gauge (glycerine bath)
- Hydraulic feet
- Safety guards
- Electric Water Inlet Shut-Off Valve
- Hydraulic lift of drawbar
- 4 Speed gearbox
- Hydraulic system by rapid couplings to tractor
- Turbine mounted on the gearbox with double built-in bypass
- Flexible connection pipe with storage reel
- Galvanized 5 wheel raingun trolley mounted on variable hard rubber wheels
- Four wheel chassis kit as standard
- Emptying compressor
- Water filter

TECHNICAL DATA

Pressure at Inlet (BAR)	Flow Rate (L/M)	Wetted Width at 80% (Mtr)
4.4 – 11.5	974 – 2455	77 – 110

Description	Code	Price
ITS090C 140mm x 500m	ITS090C140500	161,991.10

Controller Options	Code	Price
Digital 4.0 Router option for Ma-Rain 56	35400262	10,426.50
Wireless Measuring System for Ma-Rain 56 computer	35400350SKIT	1,803.50

Sprinkler Upgrade Options	Code	Price
SIME Gemini 25° 2 Speed	RGUPEXP-GEM2S	720.80
Nelson SR200 Gun	RGUPEXP-SR200K	5,706.00
Komet 202 Ultra Kit	RGUPEXP-K202U	205.60

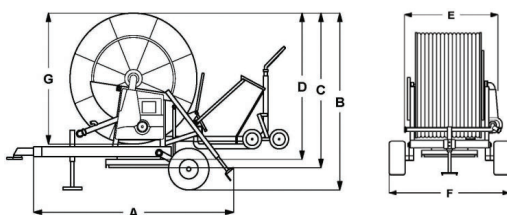

WEIGHTS AND DIMENSIONS

SIZE (cm)						
A	B	C	D	E	F	G
446	418	386	363	250	305	334

Dry Weight 8200 kg

* Please note dimensions and weights are to be used as a guide only.

MARANI HARD HOSE IRRIGATORS



MARANI HARD HOSE IRRIGATORS

IT100B

140mm x 550m

Item Code: IT100B140550



STANDARD EQUIPMENT

- Ma-Rain 56 Computer c/w solar panel and pressure switch
- SIME Explorer and nozzles
- Hydraulic lifting device of trolley
- PTO
- Winding handle
- Hydraulic rotation of turntable
- Hot galvanized chassis and reel
- Pressure gauge (glycerine bath)
- Hydraulic feet
- Safety guards
- Electric Water Inlet Shut-Off Valve
- Hydraulic lift of drawbar
- 4 Speed gearbox
- Hydraulic system by rapid couplings to tractor
- Turbine mounted on the gearbox with double built-in bypass
- Flexible connection pipe with storage reel
- Galvanized 5 wheel raingun trolley mounted on variable hard rubber wheels
- Four wheel chassis kit as standard
- Emptying compressor
- Water filter

TECHNICAL DATA

Pressure at Inlet (BAR)	Flow Rate (L/M)	Wetted Width at 80% (Mtr)
4.6 – 12.6	974 – 2455	77 – 110

Description	Code	Price
IT100B 140mm x 550m	ITS100B140550	283,856.00

Controller Options	Code	Price
Digital 4.0 Router option for Ma-Rain 56	35400262	10,426.50
Wireless Measuring System for Ma-Rain 56 computer	35400350SKIT	1,803.50

Sprinkler Upgrade Options	Code	Price
SIME Gemini 25° 2 Speed	RGUPEXP-GEM2S	720.80
Nelson SR200 Gun	RGUPEXP-SR200K	5,706.00
Komet 202 Ultra Kit	RGUPEXP-K202U	205.60

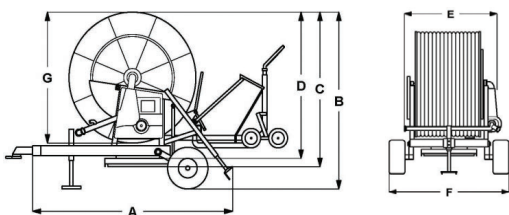

WEIGHTS AND DIMENSIONS

SIZE (cm)						
A	B	C	D	E	F	G
498	450	420	396	265	312	363

Dry Weight 7250 kg

* Please note dimensions and weights are to be used as a guide only.



MARANI HARD HOSE IRRIGATORS

MARANI HARD HOSE IRRIGATORS

IT100B

140mm x 600m

Item Code: IT100B140600



STANDARD EQUIPMENT

- Ma-Rain 56 Computer c/w solar panel and pressure switch
- SIME Explorer and nozzles
- Hydraulic lifting device of trolley
- PTO
- Winding handle
- Hydraulic rotation of turntable
- Hot galvanized chassis and reel
- Pressure gauge (glycerine bath)
- Hydraulic feet
- Safety guards
- Electric Water Inlet Shut-Off Valve
- Hydraulic lift of drawbar
- 4 Speed gearbox
- Hydraulic system by rapid couplings to tractor
- Turbine mounted on the gearbox with double built-in bypass
- Flexible connection pipe with storage reel
- Galvanized 5 wheel raingun trolley mounted on variable hard rubber wheels
- Four wheel chassis kit as standard
- Emptying compressor
- Water filter

TECHNICAL DATA

Pressure at Inlet (BAR)	Flow Rate (L/M)	Wetted Width at 80% (Mtr)
4.7 – 13.1	974 – 2455	77 – 110

Description	Code	Price
IT100B 140mm x 600m	ITS100B140600	223,796.50

Controller Options	Code	Price
Digital 4.0 Router option for Ma-Rain 56	35400262	10,426.50
Wireless Measuring System for Ma-Rain 56 computer	35400350SKIT	1,803.50

Sprinkler Upgrade Options	Code	Price
SIME Gemini 25° 2 Speed	RGUPEXP-GEM2S	720.80
Nelson SR200 Gun	RGUPEXP-SR200K	5,706.00
Komet 202 Ultra Kit	RGUPEXP-K202U	205.60

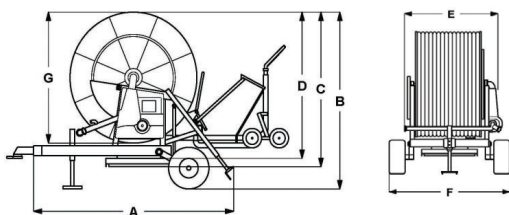

WEIGTHS AND DIMENSIONS

SIZE (cm)						
A	B	C	D	E	F	G
498	450	420	396	265	312	363

Dry Weight 7250 kg

* Please note dimensions and weights are to be used as a guide only.

MARANI HARD HOSE IRRIGATORS



MARANI HARD HOSE IRRIGATORS

IT100B

140mm x 700m

Item Code: IT100B140700



STANDARD EQUIPMENT

- Ma-Rain 56 Computer c/w solar panel and pressure switch
- SIME Explorer and nozzles
- Hydraulic lifting device of trolley
- PTO
- Winding handle
- Hydraulic rotation of turntable
- Hot galvanized chassis and reel
- Pressure gauge (glycerine bath)
- Hydraulic feet
- Safety guards
- Electric Water Inlet Shut-Off Valve
- Hydraulic lift of drawbar
- 4 Speed gearbox
- Hydraulic system by rapid couplings to tractor
- Turbine mounted on the gearbox with double built-in bypass
- Flexible connection pipe with storage reel
- Galvanized 5 wheel raingun trolley mounted on variable hard rubber wheels
- Four wheel chassis kit as standard
- Emptying compressor
- Water filter

TECHNICAL DATA

Pressure at Inlet (BAR)	Flow Rate (L/M)	Wetted Width at 80% (Mtr)
4.4 – 11.0	974 – 2455	77 – 110

Description	Code	Price
IT100B 140mm x 700m	ITS100B140700	288,602.00

Controller Options	Code	Price
Digital 4.0 Router option for Ma-Rain 56	35400262	10,426.50
Wireless Measuring System for Ma-Rain 56 computer	35400350SKIT	1,803.50

Sprinkler Upgrade Options	Code	Price
SIME Gemini 25° 2 Speed	RGUPEXP-GEM2S	720.80
Nelson SR200 Gun	RGUPEXP-SR200K	5,706.00
Komet 202 Ultra Kit	RGUPEXP-K202U	205.60

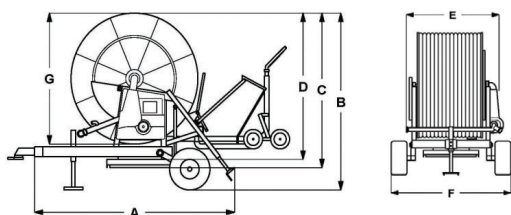

WEIGHTS AND DIMENSIONS

SIZE (cm)						
A	B	C	D	E	F	G
498	450	420	396	265	312	363

Dry Weight 7250 kg

* Please note dimensions and weights are to be used as a guide only.



ORMA

HARD HOSE IRRIGATORS



The elegant, safe and simple irrigators for gardening, horticulture, sports and agriculture.

The innovative high performance ORMA turbine drive allows the utilisation with various water qualities, including recycled and the possibility to add fertilizers.

Their range of irrigators are the result of the ongoing innovation and experience since the 1970s.

The ORMA irrigation machines are characterized by careful attention to details, robustness and ease of use.

Applications for the range include:

Turf Watering

playing fields, parks, gardens, lawn planting, golf courses, race courses.

Agriculture

Small crops, nurseries, turf farms.



THE RANGE



LEADER 20



LEADER 25



LEADER 32



LEADER 40



ORMA HARD HOSE IRRIGATORS

LEADER 20



SIZES AVAILABLE

- 20mm x 40m

Description	Code	Price
Leader 20 Turbine 20mm x 40m	GC2040	2,239.00

STANDARD EQUIPMENT

- Automatic hose rewind through the turbine water drive with low absorption
- Adjustable Sprinkler density
- SIME Part Circle Junior sprinkler c/w 4mm nozzle
- Stopping device at end of irrigation
- Handle
- Sprinkler trolley on wheels
- 5 mtr flexible connection hose

TECHNICAL DATA

Model	Pressure at Inlet (BAR)	Flow Rate (L/M)	Wetted Width at 85% (Mtr)
20/40	2 - 4	10.8 - 15	17 - 21

Model	Dimensions		Weight
	cm	inch	kg
Leader 20	40 x 80 x 45	16 x 32 x 18	33



ORMA HARD HOSE IRRIGATORS

LEADER 25

ORMA HARD HOSES



SIZES AVAILABLE

- 25mm x 50m

Description	Code	Price
Leader 25 Turbine 25mm x 50m	GC2550	5,110.10

STANDARD EQUIPMENT

- Automatic hose rewind through the turbine water drive with low absorption
- Adjustable Sprinkler density
- SIME Part Circle Silver sprinkler c/w 5mm, 6mm and 7mm nozzles
- Stopping device at end of irrigation
- Sprinkler trolley on wheels
- Automatic sprinkler trolley lifting
- Water Filter
- 3 mtr flexible connection hose

TECHNICAL DATA

Model	Pressure at Inlet (BAR)	Flow Rate (L/M)	Wetted Width at 85% (Mtr)
25/50	2.3 - 4	20 - 52	20 - 27

Model	Dimensions		Weight
	cm	inch	kg
Leader 25	60 x 76 x 85	24 x 30 x 34	60



ORMA HARD HOSE IRRIGATORS

LEADER 32



SIZES AVAILABLE

- 32mm x 70m
- 32mm x 120m

Description	Code	Price
Leader 32 Turbine 32mm x 70m	GC3270P	7,659.80
Leader 32 Turbine 32mm x 120m	GC32120A	10,330.50

STANDARD EQUIPMENT

- Automatic hose rewind through the turbine water drive with low absorption
- Adjustable Sprinkler density
- SIME Part Circle Funny sprinkler c/w 6mm, 7mm and 8mm nozzles
- Stopping device at end of irrigation
- Sprinkler trolley on wheels
- Automatic sprinkler trolley lifting
- Water Filter
- 3 mtr of flexible connection hose

TECHNICAL DATA

Model	Pressure at Inlet (BAR)	Flow Rate (L/M)	Wetted Width at 85% (Mtr)
32/70	3 - 6	32 - 80	25 - 35
32/120	4.2 - 6	39 - 80	28 - 35



ORMA HARD HOSE IRRIGATORS

LEADER 40

ORMA HARD HOSES



SIZES AVAILABLE

- 40mm x 120m

Description	Code	Price
Leader 40 Turbine 40mm x 120m	GC40120A	11,086.90

STANDARD EQUIPMENT

- Aluminium Turbine with sprinkler trolley
- SIME Part Circle K1 sprinkler c/w 8mm, 9mm and 10mm nozzles
- Adjustable flow rate and irrigation speed
- Automatic stop and water stopping at end irrigation
- Sprinkler trolley lifting
- Water Filter
- 3 mtr of flexible connection hose

TECHNICAL DATA

Model	Pressure at Inlet (BAR)	Flow Rate (L/M)	Wetted Width at 85% (Mtr)
40/120	3.9 - 6.0	57 - 124	29 - 32

Model	Dimensions		Weight
	cm	inch	kg
Leader 40	145 x 103 x 140	57 x 41 x 55	210

ORMA HARD HOSE IRRIGATORS

The elegant, safe and simple irrigators
for gardening, horticulture, sports and agriculture.







RAINSPAN

BOOM IRRIGATORS



The Rainspan Boom Irrigator Range has evolved into the most reliable, strongest, efficient and user friendly machine.

The range has a unique turbine technology to provide the most efficient, lowest pressure, economical travelling boom in the industry. Other features of the Rainspan Range include:

- On Board Hose Reel Perma-coupled hose makes it easy to lay out hose and cable in the one operation
- Gearbox for smooth safe operation specifically designed for Irrigators
- New Generation Turbines that are the best in the industry
- Reliable High volume Purge Pump
- Boom lengths from 54m (64m wetted width) to 99m (119m wetted width)
- Runs up to 600m
- Auto stop



Why Rainspan Soft Hose Booms?

SAVE WATER!

A high degree of uniformity, (85% or better in the SB2000 machines), in water application along with the fact that the water is applied directly where it's required ensures a minimum of waste. Little water can be lost by evaporation or wind drift. In fact, it is rare that conditions would be too windy to irrigate with the SB Boom Irrigator.

SAVE TIME!

The Rodney Industries SB Boom Irrigator is easily moved and operated by one person and requires minimal maintenance due to its outstanding simplicity and reliability. Larger volumes of water can be applied in shorter periods of time and there is no laborious shifting of spray lines etc. The boom can be slewed hydraulically allowing easy manoeuvring from the tractor while in transit.





RAINSPAN BOOM IRRIGATORS

FAQs

Will I save water?

Yes. As you are putting water where you want it, you don't have to put as much on and the overlap is a lot less than a typical gun operation. You can expect to save as much as 40% to a typical big gun application.

Is the uniformity good?

The uniformity is excellent in the SB2000's! With the inclusion of a compensator as standard on these machines you can expect to get at least 85% uniformity over the pass (even in windy conditions). It has been reported as much as 96% uniformity in some trials.

Can I operate when the wind is up?

The wind can not stop a Rainspan. With the Nelson R3000 rotator sprinklers or the Seninger X I Wob, and the design of the boom, we will still operate efficiently even when the wind is up. We have booms operating in the windiest of conditions such as seen in North Queensland and New Zealand where our booms excel.

What is the overlap that you recommend?

The overlap for all booms, (including end guns) is 2 metres of wetted width.

It looks difficult to manoeuvre around; is it?

Many people have the perception that booms are really difficult to manoeuvre. This is not the case! It is really user friendly to manoeuvre and can be done as a 1 man operation. As the boom can be slewed from the tractor, you can get around the farm easily with care. This can generally be done in approx 30 minutes.

I hear some booms tip over easily; are Rainspan's the same?

The Rainspan Boom is designed for strength and stability. They do not tip over and operate in conditions that other booms just won't operate. We have had an instance where 3 pivots went over, whilst the 80mtr boom escaped unscathed.

I'm having trouble getting to all the corners of my block with my pivot; will this help?

As the boom walks laterally you can cover 100% of your blocks and irrigate every square inch required. A lot of our booms that are sold go hand in hand with pivots and are used in the areas where the pivot can't get to.

Can I pump effluent with it?

The turbine on the SB2000 range are designed to take effluent without any problems. We currently have machines pumping effluent that have been going for many years now and do not look like failing.

How strong is it?

Rodney Industries is known for the quality of the metals range and the core value of the business is "products that last". This is certainly true for the Rainspan Booms that are that strong you can drive over the pipes that are used to build the boom out of. The Rainspan Boom has stood the test of time and as they are hot dipped galvanised, they will last and last.



WHAT'S IN A TURBINE?

Rainspan's state-of-the-art Axial Water Turbine is a very simple and powerful motor at the heart of the SB2000.

Requiring no fuel, batteries or electricity and very little maintenance, it is an excellent alternative to combustion engines.

The quality and simplicity of both design and componentry make Rainspan's Turbine unique and superior to all others.

All components are abrasion and corrosion resistant and are machined and assembled to very high standards making it very reliable for many years.

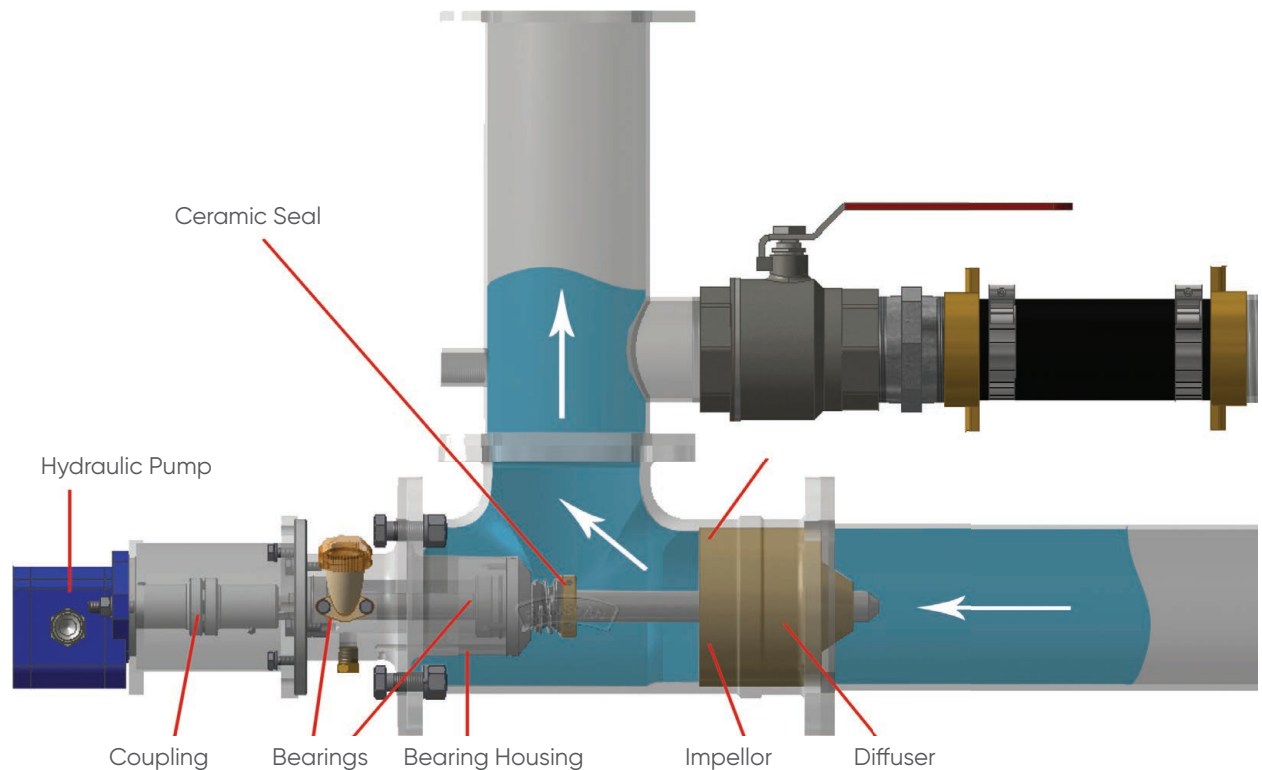



RAINSPAN BOOM IRRIGATORS

BOOM LAYOUT

Plan View

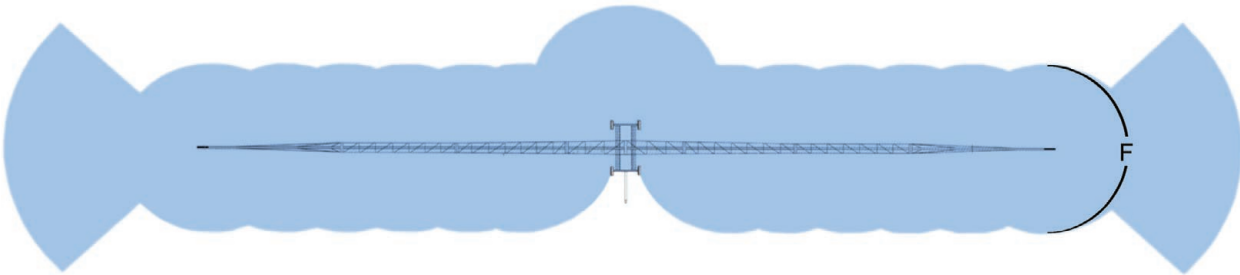

Side View

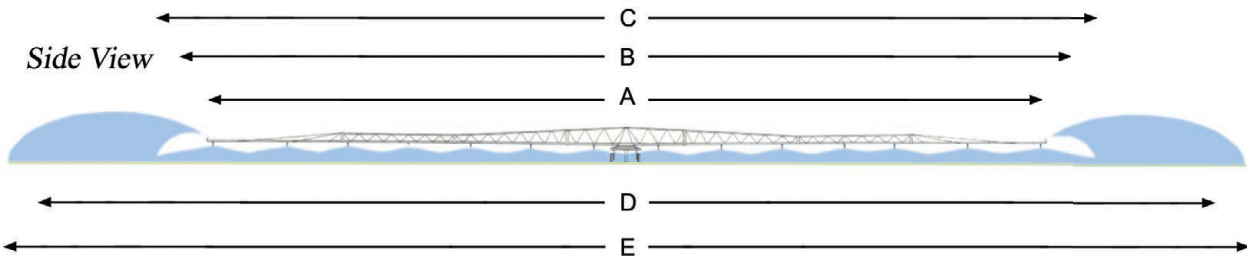

- The overlap for all booms, (including end guns) is 2m of wetted width
 - To calculate the overlap. Nelson PCR3000 Relative Throw Distance 7m to 12m
 - To calculate the overlap with End Guns. Sime K1 Teso 8° Relative Throw Distance 12m. (eg Width of boom 41m + Throw 24m = 65m – overlap 4m = 61m wetted width overlap each side 2m.)
- A. Boom length
 - B. Wetted Width with 5m each end
 - C. Overlap is wetted width with 2m each end
 - D. Wetted width with End Guns add 10m each end
 - E. Overlap with end guns
 - F. Sprinkler Diameter 15m





SETTING SPEED CONTROL

- Set speed by (SB2000 have Hydrostatic flow divider) (SB550 have multiple speed gearboxes and water bypass leaver.
- Measuring speed on base model by simply measuring mm / min the Irrigator is walking. The wetted width is 51m, length of run 400m, flow is 10 LPS and the water application is 25mm the machine has to be walking at 470.59mm per min.

Without Computer Controller

Wetted Width		51 Mtrs	Run Length 400Mtrs									
Flow Range			mm Applied									
GPH	LPS		10	15	20	25	30	40	50	75	100	
7930	10	Speed (mm / min)	1176.47	784.314	588.235	470.588	392.157	294.118	235.294	156.863	117.647	
		Run Time (Hr)	5.7	8.5	11.3	14.2	17.0	22.7	28.3	42.5	56.7	

- Measuring speed with controllers by simply reading the display m / hr the Irrigator is walking. The wetted width is 51m, length of run 400m, flow is 10 LPS and the water application is 25mm the machine has to be walking at 14.2m per hour.

With Computer Controller

Wetted Width		51 Mtrs	Run Length 400Mtrs									
Flow Range			mm Applied									
GPH	LPS		8	10	15	20	25	30	40	50	75	100
7930	10	Speed (m / hr)	88.24	70.59	47.06	35.29	28.24	23.53	17.65	14.12	9.41	7.06
		Run Time (Hr)	4.53333	5.7	8.5	11.3	14.2	17.0	22.7	28.3	42.5	56.7

Completion of Run

- Once the Irrigator has completed run disconnect irrigator from anchor.
- Remove hose from Hydrant.
- Using 3 point tow hitch in figure A connect to caster. Lift front wheel a little off the ground.
- Purge Hose using PTO supplied connected to Purge and Tractor.
- Wind on hose by changing from Purge to Hose reel drive.
- Once hose is re wound irrigator is ready to shift again.

Each Model is a little different so correct procedure will need to be checked it the appropriate user Manual.



RAINSPAN BOOM IRRIGATORS

LAYING HOSE AND CABLE



Photo 1:

Connect hose to layout bar and cable to tractor pull



Photo 2:

Wrap hose around rear roller



Photo 3:

Begin laying hose

- Unhitch irrigator from tractor and slide layout bar into three-point tow hitch.
- Position hose guide arm on the same side of the lane as the hydrant and lock in place. This will be the side to lay the hose.
- Pull hose through the roller guides and around the rear layout roller on guide arm (Photo # 2) Connect hose coupling to layout bar with supplied chains (Photo # 1).
- Release the cable drum.
- Connect winch cable to tractor pull (Photo # 1).
- With the tractor, slowly pull the hose and winch cable from the irrigator (Photo # 3) until reaching the hydrant. Remove hose from layout bar and connect to hydrant.
- Drive on to the point where you want the irrigator to stop watering and apply parking brakes to tractor or connect to anchor and check stop plate.
- Return to irrigator unwind remaining surplus hose from the reel.
- Re-engage the cable drum gearbox drive.
- Make sure water flow tap is open.
- Start pump and check pressures.



TRANSPORTING THE IRRIGATOR

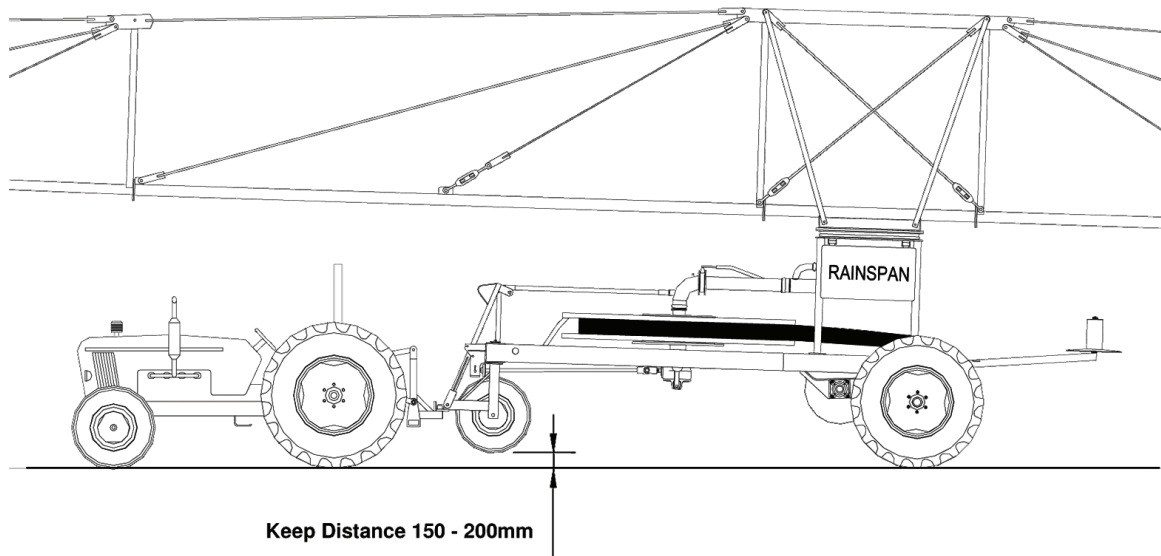

- Three Wheeled chassis makes towing very simple by lifting the front wheel off the ground. With the supplied Tractor Hitch it can be lifted or lowered to avoid obstacles going through gullies, over contours, towing from field to field across roads, between sheds, houses and around other Irrigators like Center Pivots. Easy as towing a trailer (figure A)
- Simply Disengage slew gear lock
- Connect hydraulic hoses to tractor remotes ready to slew. (Standard SB2000. Option SB550)
- Hydraulics are operated from Tractor seat
- Slew boom until tips are in-line with direction of travel
- Proceed at walking pace to the start of Run



THE OPTIONS



800 SERIES CONTROL VALVE

- Used for high pressure shutdown at pump.
- High-flow capacity with low friction loss.
- Special natural rubber sleeve diaphragm which is resilient under high pressure, resistant to common irrigation chemicals, and flexible to assure leak-proof shutoff.



DISCHARGE VALVE

- Used for low pressure shutdown at pump.
- Polymeric coating, UV and corrosion resistant.
- Unique design creating low losses at high flow rates.



PURGE

- Quick, efficient and reliable way to purge water from hose.

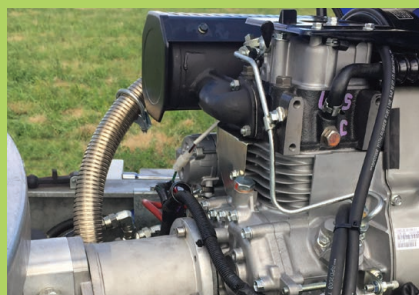

DIESEL DRIVE

- For assistance with low pressure applications.
- Enables faster retraction speeds.
- Suitable for heavy load applications - ie. hill climbs and heavy black soil.



THE OPTIONS



MECHANICAL COMPENSATOR

- The Mechanical speed Compensator controller is designed to reduce the speed of the cable drum to allow for the build up of cable on the drum.
- For every rotation of the drum there is effectively more cable wound on the drum. This will then in turn keep a consistent speed.



COMPUTER

Functions include:

- Current date and time
- Measurement of the unwound and rewind hose
- Setup of work start time
- Work speed adjustment
- Display of the irrigation time and work end time
- Closing of the irrigation cycle at the programmed distance
- Automatic stop for energy saving



BOOM SLEW FROM TRACTOR AND IRRIGATOR

- Used to manoeuvre boom around farm from tractor.



BRIGGS BOOM

- We offer a range of Briggs Booms that suit our range of Rainspan Irrigators.
- Available in both Galvanized and Stainless Steel.



BRIGGS BOOM - HIGH LIFT

- Essential for tall crops such as maize. Hydraulic lift systems are available in two versions. The first is a 'low lift' model that allows the operator to open the boom at a lower, more manageable height and then hydraulically lift the boom by 600 millimetres to give greater crop clearance of 1.9m.
- The second 'high lift' system has three lift heights – 1.9m, 2.4m and 3.1m. This is essential for tall crops such as maize.





RAINSPAN BOOM IRRIGATORS

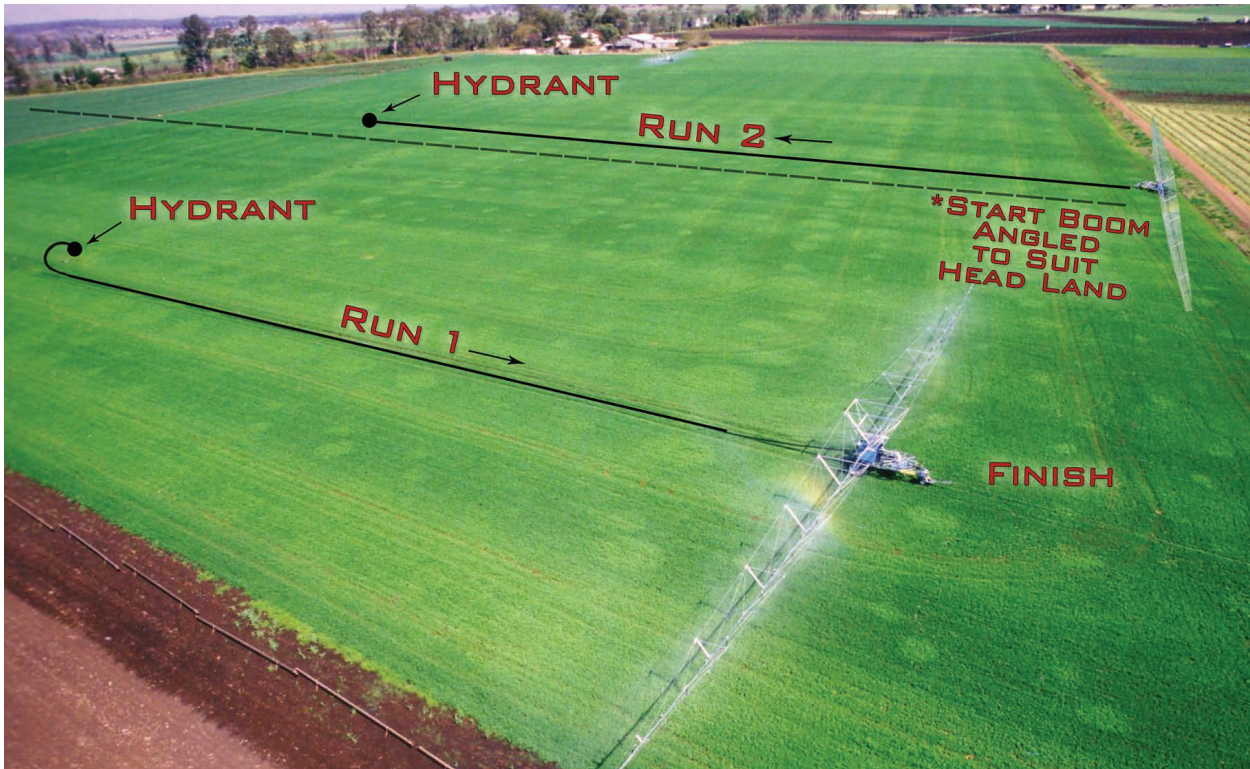

FIELD LAYOUT

- Field layout for the irrigator will depend on boom width and field dimensions as shown by the example given above
- Lanes are recommended to be kept straight level grassed mowed and free from trash
- Width of run is at least 1m wider than machine width (see specifications)
- Hydrants are located halfway and to the side of each run (Take half the width of the machine shown in specifications for model and add 1.5m)
- Each dealer will determine how much over laps is needed to suit the crop requirements, field arrangement and wind conditions in their particular area. A standard 2m overlap is recommended





RAINSPAN BOOM IRRIGATORS

RAINSPAN ENQUIRY FORM

Farm Details

Dimensions: Area: Acres or Ha

Run Length: Metres Run Widths: Metres

Hydrant Spacings: Metres Slopes:

Towing Lanes: Yes /No Width of Lanes Metres

Water Supply Source: River / Dam / Bore / Well / Flooding / Channel / Other:

Details of Water Quality:

Flow Rate: GPH / LPH / LPM / M³H Supply Pressure: Bar/PSI

Soil Type: Crops Grown:

Required Watering Rate/s:

Drawing of Field Layout

Irrigator Details

Model: SB550 / SB2000 Tower: 2.1 / 2.4 / 3.0 / 3.5 Tower Extn: Yes / No Height: mm

Boom: 54 60 67 73 80 86 93 99 Galv / Stainless Steel

Cable: Galv Size: mm x Metres

Hose Brand: Angus / Snap-Tite / Gollmer Hose Size: mm x Metres

Other:

Notes

.....

.....

.....

.....



THE RANGE



SB550



SB2000



RAINSPAN BOOM IRRIGATORS

RAINSPAN BOOMS



SB550

SB 550 Base Irrigator	Code	Price
Radial Flow Turbine Drive		
4 Speed Gearbox		
2.2m Tower		
9mm Ø x 520m Cable		
4" Hose Reel		
Purge Pump	R550	73,341.40
PTO Shaft		
10.5 x 16.5" front tyre (tractor) 14.9 x 24" rear tyres (tractor).		
Flow range between 11LPS to 25LPS		
*Does not include Hose / Boom		
SB 550 Folding Boom Base Irrigator	Code	Price
As above with folding boom capability R550	R550FB	73,341.40
*Does not include Hose / Boom		
SB 550 No Hose Reel	Code	Price
Radial Flow Turbine Drive		
2.2m Tower		
9mm Ø x 520m Cable		
14.9 x 24" rear (tractor) tyres.	R550NHR	51,208.60
Flow range between 11LPS to 25LPS		
*Does not include Hose / Boom		
SB 550 Diesel Drive	Code	Price
Diesel Drive		
2.2m Tower		
9mm Ø x 520m Cable		
4" Hose Reel		
Purge Pump	R550D	85,176.30
PTO Shaft		
14.9 x 24" rear (tractor) tyres.		
Flow range between 11LPS to 25LPS		
*Does not include Hose / Boom		



RAINSPAN BOOM IRRIGATORS



RAINSPAN BOOMS



SB550

Boom (H/D Galvanized)

Includes Nelson R3000 Rotating Sprinklers on every (2nd)* Second outlet, or at ** every outlet to accommodate higher flow rates.

Each R3000 sprinkler includes a (galv) gooseneck and 300mm Dropper.

Options available - Please contact Sales Office for pricing

In-line Filter	POA
High Pressure Shutdown Valve	POA
Tyre Sizes and Patterns (other than standard rear 14.9 x 24")	POA
2 x end guns K1 8°	POA
Hydraulic Slew	POA
2 x R55 Nelson End Guns	POA
SB550 Startec 130 Assy	POA
SB550 Startec 260 Assy	POA

Boom Options				
Boom Width	No. of Sprinklers	Flow Rates	Code	Price
54	*14	(13,755 gph/17 lps max flow)	R55054	POA
67	*18	(17,680 gph/22 lps max flow)	R55067	POA
74	*20	(19,650 gph/25 lps max flow)	R55074	POA

* Minimum sprinkler outlets are set at 4.3m centres, (ie. every 2nd outlet)

** Maximum sprinkler outlets are set at 2.15m centres, (ie. every outlet)



Briggs Boom Options			
Size		Code	Price
R50/2	Please refer to Briggs Irrigation chapter for detailed specifications	HH7525KIT	POA
R64/2	Please refer to Briggs Irrigation chapter for detailed specifications	HH7530KIT	POA



RAINSPAN BOOM IRRIGATORS



SB2000

SB 2000 Standard	Code	Price
Axial Flow Turbine Drive		
2.4m Tower		
10mm Ø x 520m Cable		
4" Hose Reel		
Purge Pump		
PTO Shaft	R2000	92,951.40
Hydraulic Boom Slew		
16.9 x 28" rear tractor tyres.		
Flow range between 15LPS to 44LPS		
*Does not include Hose/ Boom		

SB 2000 NO HOSE REEL	Code	Price
Axial Flow Turbine Drive		
2.4m Tower		
10mm Ø x 520m Cable		
Hydraulic Boom Slew	R2000NHR	73,447.40
16.9 x 28" rear tractor tyres.		
Flow range between 15LPS to 44LPS		
*Does not include Hose/ Boom		



SB 2000 Diesel Drive	Code	Price
Diesel Drive		
2.4m Tower		
10mm Ø x 520m Cable		
4" Hose Reel		
Purge Pump		
PTO Shaft	R2000D	104,786.30
Hydraulic Boom Slew		
16.9 x 28" rear tractor tyres.		
Flow range between 15LPS to 44LPS		
*Does not include Hose/ Boom		

RAINSPAN BOOM IRRIGATORS



RAINSPAN BOOMS



SB2000

Boom (H/D Galvanized)

Includes Nelson R3000 Rotating Sprinklers on every (2nd)* Second outlet, or at ** every outlet to accommodate higher flow rates

Each R3000 sprinkler includes a (galv) gooseneck and 300mm Dropper.

Options available - Please contact Sales Office for pricing

3.5m Tall Tower	POA
3.1m Mid Tower	POA
Wire Rope Upgrade	POA
In-line Filter	POA
4.0" Double Hose Reel	POA
4.5" Hose Reel	POA
4.5" Double Hose Reel	POA
Remote Slew Adaptor on Irrigator	POA
High Pressure Shut Down Valve	POA
SB2000 Startec 130 Assy	POA
2 x end guns	POA
Mechanical Speed Compensator	POA
SB2000 Startec 260 Assy	POA

Boom Options				
Boom Width	No. of Sprinklers	Flow Rates	Code	Price
67	*18	(17,680 gph/22 lps max flow)	RBK67	POA
74	*20	(19,650 gph/25 lps max flow)	RBK74	POA
80	*22	(21,600 gph/27 lps max flow)	RBK80	POA
87	*24	(23,580 gph/29.7 lps max flow)	RBK87	POA
93	*24	(23,580 gph/29.7 lps max flow)	RBK93	POA
100	*26	(25,550 gph/32 lps max flow)	RBK99	POA

BRIGGS

BOOM IRRIGATORS



Briggs boom irrigators are an established feature of the farming landscape.

Efficient, tough, reliable and surprisingly versatile, the modern Briggs range has been tried and tested by farmers, growers and groundsmen around the world.

All Briggs booms are manufactured in the UK to the same high standards and can be operated with almost any make and size hose reel. Making them the perfect partner for our range of Marani Hard Hose Irrigators.

Briggs booms are based either on a four-wheel chassis or on a three-wheel chassis which allows the whole boom to be transported on the hose reel. (Hose reel mounted).

The linear booms available through the Briggs range start from 18 metres right through to 76 metres.

WHY BRIGGS BOOMS?

UNIFORMITY

- Closely spaced nozzles plus low trajectory equals 90% uniformity, (even in quite windy conditions)
- Benefits include savings in water and more even crop growth.

SOIL BENEFITS

- Controlling droplet size reduces risk of soil capping or 'slumping', compared with a raingun.

REDUCED DROPLET SIZE

- Nelson pressure regulated sprayjets allow the optimum droplet size to be selected for each type of crop. For example, small droplets for leafy salads or larger droplets for root crops.

LESS ENERGY NEEDED

- Booms operate at pressures ranging from just half that recommended for rainguns (2 - 3.5 bar compared to 4.5 - 5.0 bar). So less pressure is needed all the way back to the pump, reducing input power costs.



THE OPTIONS

OFFSET FEED



Keeps the hose reel pipe in the wheeling, making setting up easier and reducing damage to the crop.

HIGH LIFT KIT



Essential for tall crops such as maize. Hydraulic lift systems are available in two versions. The first is a 'low lift' model that allows the operator to open the boom at a lower, more manageable height and then hydraulically lift the boom by 600 millimetres to give greater crop clearance of 1.9m.

STAINLESS STEEL PIPEWORK



Optional stainless steel pipework for corrosive liquids.

The second 'high lift' system has three lift heights – 1.9m, 2.4m and 3.1m. This is essential for tall crops such as maize.





BRIGGS BOOMS

BRIGGS BOOMS

BRIGGS ENQUIRY FORM

Farm Details

Dimensions: Area: Acres or Ha
 Run Length: Metres Run Widths: Metres
 Hydrant Spacings: Metres Slopes:
 Towing Lanes: Yes /No Width of Lanes Metres
 Crop Spacings: Metres Centre Feed or Offset feed?:
 Water Supply Source: River / Dam / Bore / Well / Flooding / Channel / Other:
 Details of Water Quality:
 Flow Rate: GPH / LPH / LPM / M³H Supply Pressure: Bar/PSI
 Soil Type: Crops Grown:
 Required Watering Rate/s:

Irrigator Details

Model: R18 / R24 / R30 / R40 / R46 / R50/2 / R64/2 / R76 High Lift: Yes / No Height:mm
 Boom: 41 47 54 60 67 73 80 86 93 99 Galv / Stainless Steel
 Other:

Notes

.....

Drawing of Field Layout

THE RANGE



R 18



R 24



R 30



R 40



R 46



R 50



R 64



R 76

BRIGGS BOOMS

BRIGGS BOOMS

R18 IRRIGATION BOOM



STANDARD EQUIPMENT

- Folding Boom
- Centre Feed and 3 wheel trolley
- Lifting Kit
- Stabiliser Legs
- Drawbar Extensions
- 3 X PCS 3000 Nelson Rotators
- 6 X S3000 Nelson Rotators
- 9 X Nelson Press\Regs & B\Valves
- Turntable

TECHNICAL DATA

Boom Length:	18m (59')
Lane Spacing:	22 – 44m (72 – 144')
Band Width:	12 – 15m (39 – 49')
Flow Capacity (m ³ \hr):	14 – 30 (233 – 500 l/m)
Operating Pressure:	15 – 60 PSI
Quantity of Outlets:	9
Track Width:	1.5 – 4.2m (60" – 165") – Standard Chassis 1.5 – 2.4m (60" – 94") – Offset Chassis
Height to Nozzle:	1.5m (2.28m for high crop fully lifted)
Compatible With:	Marani GT022B, GT026B (with 63mm and 75mm hose)

Briggs Boom to Marani Hard Hose Irrigator Option	Code	Price
R18 Briggs Boom to suit GT022B Marani Hard Hose Irrigator	R18BOOMGT22	30,104.00
R18 Briggs Boom to suit GT026B Marani Hard Hose Irrigator	R18BOOMGT26	

Machine Options	Code	Price
High Lift Version (2.4m high) hand pump hydraulics	HH7625	7,659.40

Sprinkler Options	Code	Price
R55A End Gun Kit 2 Sprinklers and Fittings per kit	R55VTKIT	1,587.90

WEIGHTS AND DIMENSIONS

Folded Length:	5m
Folded Width:	2.8m (9'3")
Weight:	400kg

R24 IRRIGATION BOOM



STANDARD EQUIPMENT

- Folding Boom
- Centre Feed and 3 wheel trolley
- Lifting Kit
- Drawbar Extensions
- Stabilisers legs
- 3 X PCR 3000 Nelson Rotators
- 8 X R3000 Nelson Rotators
- 11 X Nelson Press\Regs & B\Valves
- Turntable

TECHNICAL DATA

Boom Length:	24m (79')
Lane Spacing:	28 – 50m (91 – 164')
Band Width:	12 – 15m (39 – 49')
Flow Capacity (m ³ \hr):	14 – 44 (233 – 733 l/m)
Operating Pressure:	15 – 60 PSI
Quantity of Outlets:	11
Track Width:	1.5 – 4.2m (60" – 165") – Standard Chassis 1.5 – 2.4m (60" – 94") – Offset Chassis
Height to Nozzle:	1.5m (2.28m for high crop fully lifted)
Compatible With:	Marani GT022B, GT026B (with 63mm and 75mm hose)

Briggs Boom to Marani Hard Hose Irrigator Option	Code	Price
R24 Briggs Boom to suit GT022B Marani Hard Hose Irrigator	R24BOOMGT22	37,693.60
R24 Briggs Boom to suit GT026B Marani Hard Hose Irrigator	R24BOOMGT26	

Machine Options	Code	Price
High Lift Version (2.4m high) hand pump hydraulics	HH7625	7,659.40

Sprinkler Options	Code	Price
End section blanking plate c/w 180° Nelson R3000 Rotators	HH7675	1,219.10
R55A End Gun Kit 2 Sprinklers and Fittings per kit	R55VTKIT	1,587.90

WEIGHTS AND DIMENSIONS

Folded Length:	5m
Folded Width:	2.8m (9'3")
Weight:	400kg

BRIGGS BOOMS

R30 IRRIGATION BOOM



STANDARD EQUIPMENT

- Folding Boom
- Centre Feed and 3 wheel trolley
- Lifting Kit
- Stabiliser Legs
- Drawbar Extensions
- 3 X PCR 3000 Nelson Rotators
- 10 X R3000 Nelson Rotators
- 13 X Nelson Press\Regs\ & B\Valves
- Turntable

TECHNICAL DATA

Boom Length:	29m (95')
Lane Spacing:	34 – 54m (111' – 177')
Band Width:	12 – 15m (39 – 49')
Flow Capacity (m ³ \hr):	14 – 50 (233 – 833 l/m)
Operating Pressure:	15 – 60 PSI
Quantity of Outlets:	13
Track Width:	1.5 – 4.2m (60" – 165") – Standard Chassis 1.5 – 2.4m (60" – 94") – Offset Chassis
Height to Nozzle:	1.5m (2.28m for high crop fully lifted)
Compatible With:	Marani GT022B, GT026B (with 63mm and 75mm hose)

Briggs Boom to Marani Hard Hose Irrigator Option	Code	Price
R30 Briggs Boom to suit GT022B Marani Hard Hose Irrigator	R30BOOMGT22	38,509.80
R30 Briggs Boom to suit GT026B Marani Hard Hose Irrigator	R30BOOMGT26	
R30 Briggs Boom to suit GT030B/C Marani Hard Hose Irrigator	R30BOOMGT30	
R30 Briggs Boom to suit GT040B/C Marani Hard Hose Irrigator	R30BOOMGT40	
R30 Briggs Boom to suit GT050B Marani Hard Hose Irrigator	R30BOOMGT50	
R30 Briggs Boom to suit GT060B Marani Hard Hose Irrigator	R30BOOMGT60	

Machine Options	Code	Price
High Lift Version (2.4m high) hand pump hydraulics	HH7625	7,659.40

Sprinkler Options	Code	Price
End Section Blanking Plates c\w 180° PCR3000 Spray jets	HH7675	1,219.10
End Impact Sprinkler Kit (K1 8° Teso)	SIMEKITBRR30	466.80
R55A End Sprinkler Kit 2 guns and Fittings per kit	R55VTKIT	1,587.90

WEIGHTS AND DIMENSIONS

Folded Length:	5m
Folded Width:	3.4m (11'2")
Weight:	460kg

R40 IRRIGATION BOOM



STANDARD EQUIPMENT

- Folding Boom
- Centre Feed and 3 wheel trolley
- Lifting Kit
- Drawbar Extensions
- Stabiliser Legs
- 3 X PCR 3000 Nelson Rotators
- 14 X R3000 Nelson Rotators
- 17 X Nelson Press\Regs & B\Valves
- Turntable

TECHNICAL DATA

Boom Length:	40m (131')
Lane Spacing:	44 – 60m (144 – 197')
Band Width:	12 – 15m (39 – 49')
Flow Capacity (m ³ \hr):	20 – 50 (333 – 833l/m)
Operating Pressure:	15 – 37 PSI
Quantity of Outlets:	17
Track Width:	1.5 – 4.2m (60" – 165") – Standard Chassis 1.5 – 2.4m (60" – 94") – Offset Chassis
Height to Nozzle:	1.5m
Compatible With:	Marani GT030B to GT070B

Briggs Boom to Marani Hard Hose Irrigator Option	Code	Price
R40 Briggs Boom to suit GT030B/C Marani Hard Hose Irrigator	R40BOOMGT30	43,703.80
R40 Briggs Boom to suit GT040B/C Marani Hard Hose Irrigator	R40BOOMGT40	
R40 Briggs Boom to suit GT050B Marani Hard Hose Irrigator	R40BOOMGT50	
R40 Briggs Boom to suit GT060B Marani Hard Hose Irrigator	R40BOOMGT60	
R40 Briggs Boom to suit GT070B Marani Hard Hose Irrigator	R40BOOMGT70	

Sprinkler Options	Code	Price
End section blanking plate c/w 180° Nelson R3000 Rotators	HH7680	1,219.10
R55A End Gun Kit 2 Sprinklers and Fittings per kit	R55VTKIT	1,587.90

WEIGHTS AND DIMENSIONS

Folded Length:	5.5m (18')
Folded Width:	3.4m (11'2")
Weight:	620kg

BRIGGS BOOMS

R46 IRRIGATION BOOM



STANDARD EQUIPMENT

- Folding Boom
- Centre Feed and 3 wheel trolley
- Lifting Kit
- Drawbar Extensions
- Stabiliser Legs
- 2 X PCR 3000 Nelson Rotators
- 16 X R3000 Nelson Rotators
- 16 X Nelson Press\Regs\B\Valves
- Turntable

TECHNICAL DATA

Boom Length:	46m (151')
Lane Spacing:	50 - 66m (164- 216')
Band Width:	12 - 15m (39 - 49')
Flow Capacity (m ³ \hr):	25 - 60 (416 - 1000 l/m)
Operating Pressure:	15 - 37 PSI
Quantity of Outlets:	18
Track Width:	1.5 - 4.2 (60" - 165") Standard Chassis 1.5 - 2.2 (60" - 86") Offset Chassis
Height to Nozzle:	1.5m
Compatible With:	Marani GT040B - GTS080B

Briggs Boom to Marani Hard Hose Irrigator Option	Code	Price
R46 Briggs Boom to suit GT040B/C Marani Hard Hose Irrigator	R46BOOMGT40	52,819.80
R46 Briggs Boom to suit GT050B Marani Hard Hose Irrigator	R46BOOMGT50	
R46 Briggs Boom to suit GT060B Marani Hard Hose Irrigator	R46BOOMGT60	
R46 Briggs Boom to suit GT070B Marani Hard Hose Irrigator	R46BOOMGT70	
R46 Briggs Boom to suit GTS080B/C Marani Hard Hose Irrigator	R46BOOMGTS80	

Machine Options	Code	Price
Offset Chassis with Extra Wheel and Axle on Offset Side	HH7701	985.30
Levelling Jack For Offset Side (for Heavy Duty Chassis)	HH4636	971.50

Sprinkler Options	Code	Price
End section blanking plate c/w 180° Nelson R3000 Rotators	HH7680	1,219.10
R55A End Gun Kit 2 Sprinklers and Fittings per kit	R55VTKIT	1,587.90

WEIGHTS AND DIMENSIONS

Folded Length:	6m (20')
Folded Width:	4.15m (13'7")
Weight:	600kg

R50/2 IRRIGATION BOOM



STANDARD EQUIPMENT

- Folding Boom
- Centre Feed and 4 wheel steer
- Lifting Kit
- Drawbar Extensions
- Stabiliser Legs
- 4 X PCR 3000 Nelson Rotators
- 14 X R3000 Nelson Rotators
- 18 X Nelson Press\Regs & B\Valves
- Layflat Hose Connection Kit

TECHNICAL DATA

Boom Length:	50m (154')
Lane Spacing:	50 – 75m (154 – 246')
Band Width:	12 – 15m (39 – 49')
Flow Capacity (m ³ \hr):	22 – 72 (366 – 1200l/m)
Operating Pressure:	15 – 60 PSI
Quantity of Outlets:	18
Wheelbase	3.8m (12'6")
Track Width:	1.5 – 2.2m (60 – 86") (1.8m standard)
Height to Nozzle:	1.5m
Compatible With:	Marani GT040B to ITS080C

Description	Code	Price
R50/2 Folding Boom	HH7320	77,597.30

Machine Options	Code	Price
Offset Feed	HH7700	5,988.30
High Lift Kit	HH7760	14,306.10

Sprinkler Options	Code	Price
End Section Blanking Plates c/w 180° Nelson R3000 Rotators	HH7735KIT	1,441.60
End Impact Sprinkler Kit (K1 8° Teso)	SIMEKITBR	528.00
R55A End Gun Kit 2 Sprinklers and Fittings per kit	R55VTKIT	1,587.90

WEIGHTS AND DIMENSIONS

Folded Length:	7.4m
Folded Width:	3.5m (11'6")
Weight:	1660kg

BRIGGS BOOMS

R64/2 IRRIGATION BOOM



STANDARD EQUIPMENT

- Folding Boom
- Centre Feed and 4 wheel steer
- 4 X PCR 3000 Nelson Rotators
- 18 X R3000 Nelson Rotators
- 22 X Nelson Press\Regs & B\Valves
- Layflat Hose Connection Kit

TECHNICAL DATA

Boom Length:	64m (210')
Lane Spacing:	68 – 90m (223 – 295')
Band Width:	12 – 15m (39 – 49')
Flow Capacity (m ³ \hr):	22 – 82 (366 – 1366 l/m)
Operating Pressure:	15 – 60 PSI
Quantity of Outlets:	22
Wheelbase	3.8m (12'6")
Track Width:	1.5 – 2.2m (60 – 86") (1.8m standard)
Height to Nozzle:	1.5m
Compatible With:	Marani GT040B to ITS080C

Description	Code	Price
R64/2 Folding Boom	HH7322	84,052.70

Machine Options	Code	Price
Offset Feed	HH7700	5,988.30
High Lift Kit	HH7760	14,306.10

Sprinkler Options	Code	Price
End Section Blanking Plates c/w 180° Nelson R3000 Rotators	HH7731KIT	POA
End Impact Sprinkler Kit (K1 8° Teso)	SIMEKITBR	528.00
R55A End Gun Kit 2 Sprinklers and Fittings per kit	R55VTKIT	1,587.90

WEIGHTS AND DIMENSIONS

Folded Length:	3.65m (12")
Folded Width:	3.8m (12'6")
Weight:	1870kg

R76 IRRIGATION BOOM



STANDARD EQUIPMENT

- Folding Boom
- Trolley
- Centre Feed and 4 wheel steer
- 3.1 mtr Hydraulic Lift
- Drawbar Extensions
- Stabiliser Legs
- 4 X PCR 3000 Nelson Rotators
- 14 X R3000 Nelson Rotators
- 18 X Nelson Press \Regs & B \Valves
- Layflat Hose Connection Kit

TECHNICAL DATA

Boom Length:	76m (250')
Lane Spacing:	80 – 96m (262' – 315')
Band Width:	12 – 15m (39 – 49')
Flow Capacity (m ³ \hr):	22 – 82 (366 – 1366l/m)
Operating Pressure:	15 – 37 PSI
Quantity of Outlets:	26
Wheelbase	3.8m (12'6")
Track Width:	1.5 – 2.2m (60 – 86") (1.8m standard)
Height to Nozzle:	1.5m – 1.9m – 2.5. – 3.1m
Compatible With:	Marani GT040B to ITS080C

Description	Code	Price
R76 Folding Boom	HH7332	111,061.50

Machine Options	Code	Price
Offset Feed	HH7700	5,988.30

Sprinkler Options	Code	Price
R55A End Gun Kit 2 Sprinklers and Fittings per kit	R55VTKIT	1,587.90

WEIGHTS AND DIMENSIONS

Folded Length:	7.4m
Folded Width:	3.8m (12'8")
Weight:	2200kg

SERVICE

Our Team is there for Yours

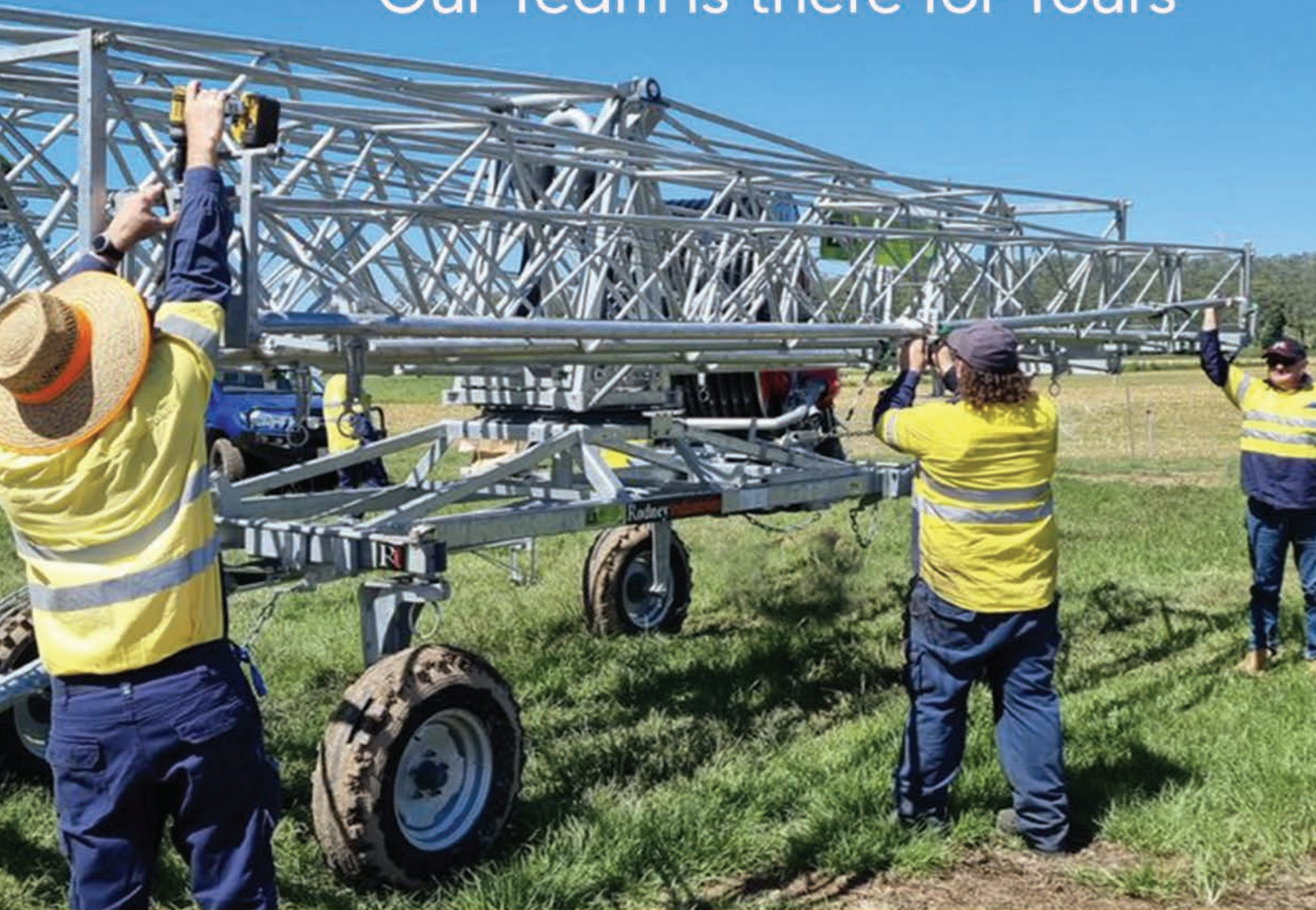

**Rodney
Industries**

A Division of Vinidex Pty Limited

COMMISSIONING

At Rodney Industries, we offer you and your customer the complete package when it comes to your Irrigation Project.

Ask our friendly Sales Team today about commissioning options for your next project.



MARANI SPRAY BOOMS



For the full Marani package, why not consider a Marani Spray Boom. Especially designed and constructed to benefit crop cultivated on large acreages.

Features include:

- Low pressure operation
- Superfine atomised spray
- Uniform irrigation unaffected by wind
- Boom structure in aluminium section pipe
- Folding structure on galvanized steel hinge
- Pivoting structure
- Galvanized steel off-set trolley with 5 pneumatic wheels
- Available in 26, 38 or 42 metres

MARANI SPRAY BOOMS



MARANI SPRAY BOOMS



	Boom Size (mtrs)	Operation Width (mtrs)	Boom Pressure (ATM)	Total Flow Rate (L/Min)	Suits Marani Model
Tech Data	13	19	1,0 – 3,0	185 – 365	F010B 50/170 – GT020B
	26	32	1,0 – 3,0	302 – 976	GT022B – GT030B
	38	44	1,0 – 3,0	392 – 1296	GT030B – GTS080B
	42	48	1,0 – 3,0	446 – 1488	GT030B – GTS080B

Size	Description	Code	Price
13 mtr	Basic with plastic jets	LPSB13MBASIC	POA
26 mtr	Basic with plastic jets	LPSB26M5WBASIC	POA
	Complete with Nelson Regulators and Rotator Sprinklers	LPSB26M5WKIT	POA
38 mtr	Basic with plastic jets	LPSB38M5WBASIC	POA
	Complete with Nelson Regulators and Rotator Sprinklers	LPSB38M5WKIT	POA
42 mtr	Basic with plastic jets	LPSB42M5WBASIC	POA
	Complete with Nelson Regulators and Rotator Sprinklers	LPSB42M5WKIT	POA

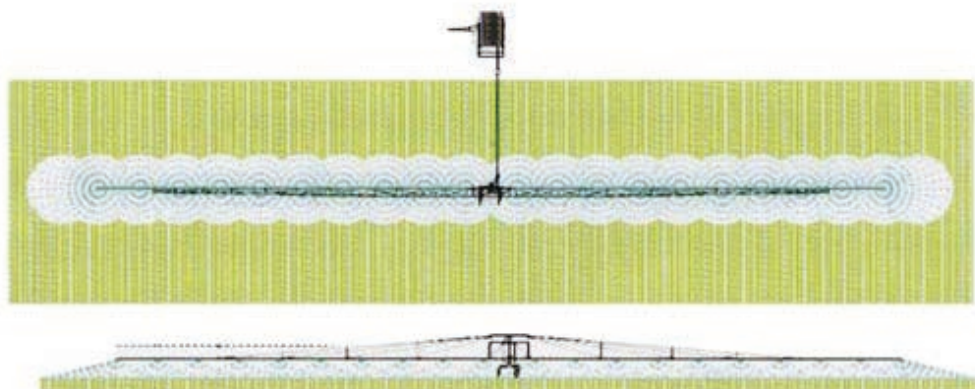

DIESEL PUMP SETS

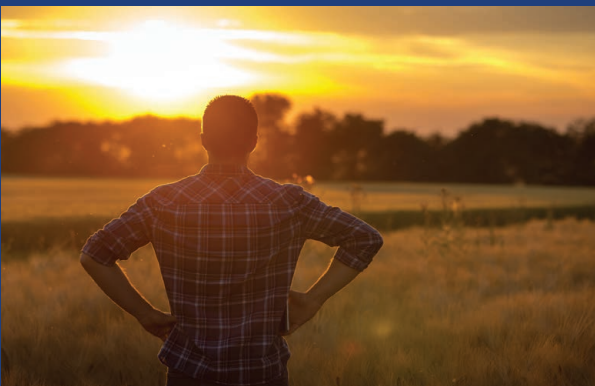

At Rodney Industries, we understand the importance of range, reliability and performance. That is why we offer a selection of Pumps and Motors from leading international brands for your Diesel Pump Sets.

Rodney Industries offers an ideal solution to solve your remote and transportable diesel pumping needs. We can provide a selection of Pumps and Motors from leading international brands. The quality build and features stand out and have proven to exceed customer expectations with performance and finish.

Choose from Iveco, Lombardini-Perkins or John Deere diesel motors coupled with reliable Caprari and Rovatti Pumps that are ideal for water transfer, operating Hard and Soft Hose Irrigators as well as hose pull Laterals.



DIESEL PUMP UNITS



THE RANGE



J02C002KIT



J04C011KIT



K08R715KIT



I15C011KIT



I26C001KIT



I73C002KIT



I75C001KIT

For additional machines, please refer to our Diesel Pump brochure.

DIESEL PUMP UNITS



JOHN DEERE



J02C002KIT

JOHN DEERE ENGINE WITH CAPRARI PUMP



STANDARD EQUIPMENT

- JOHN DEERE D4045TF250-01 4 Cylinder Turbo 4500CC water-cooled diesel engine, complete with engine liquids.
- Caprari MEC MG 80-4/3A Pump.
- Mounted on two pneumatic wheels trolley, with built in 360 litre tank.
- Centrifugal flanged pump coupled to the engine through flexible joint.
- Battery.
- ELCOS CEM 250/00 control panel with electric system, engine control device, transducer for high pressure and low pressure alarm, 24 hour timer.
- ABS roof.
- Engine running indicator light on roof.
- Work light for around unit.

Code	Price
J02C002KIT	56,561.60

Machine Options	Code	Price
Priming System Kirpy	406053	1,022.90
Electric Priming Pump	EPP	2,035.20

Computer Options	Code	Price
Upgrade to Elcos CIM 131	CIM131UPGRADE	2,530.80
Upgrade to Elcos CIM 137	CIM137UPGRADE	3,483.20

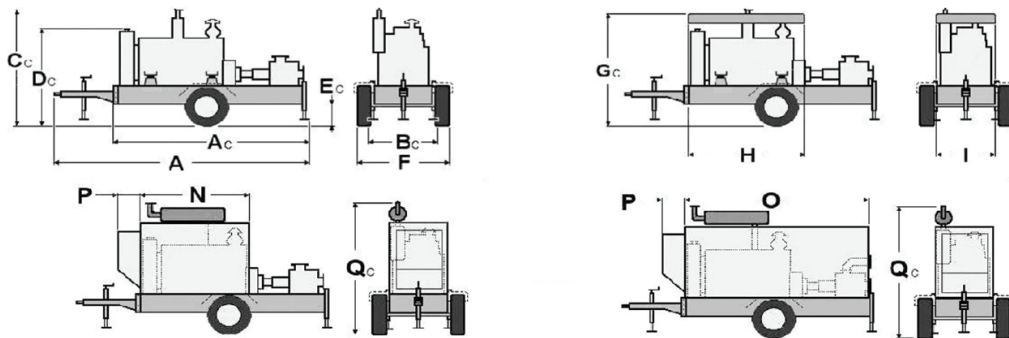

WEIGHTS AND DIMENSIONS

SIZE (cm)													
A	Ac	Bc	Cc	Dc	Ec	F	Gc	H	I	N	O	P	Qc
345.9	211.5	122.9	263.7	165.1	34	145	180	130	100	128	200	40	227.5

* Please note dimensions are to be used as a guide only.



DIESEL PUMP UNITS

DIESEL PUMP UNITS



JO2C002KIT

JOHN DEERE ENGINE
WITH CAPRARI PUMP

CAPRARI PUMP MEC-MG 80-4/3A PUMP PERFORMANCE RANGE

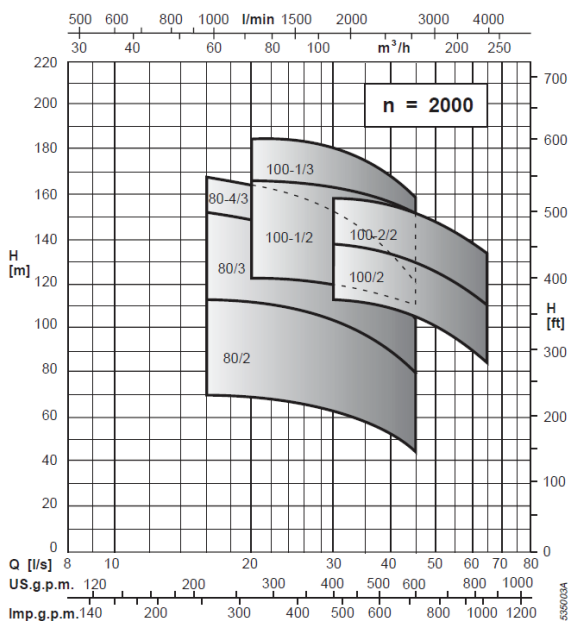
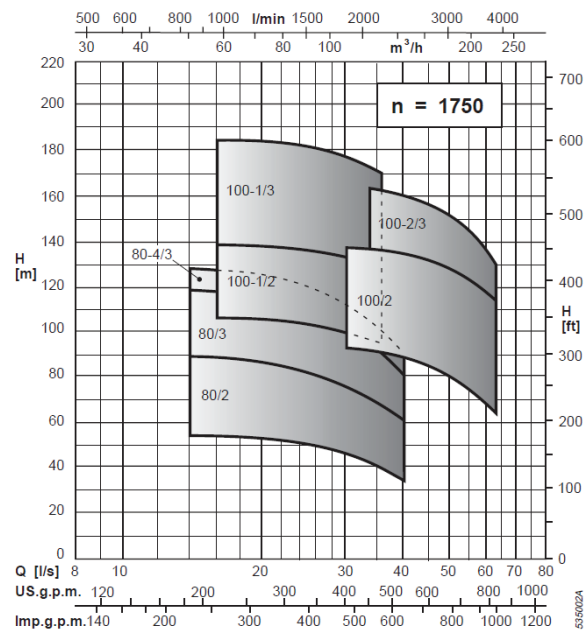
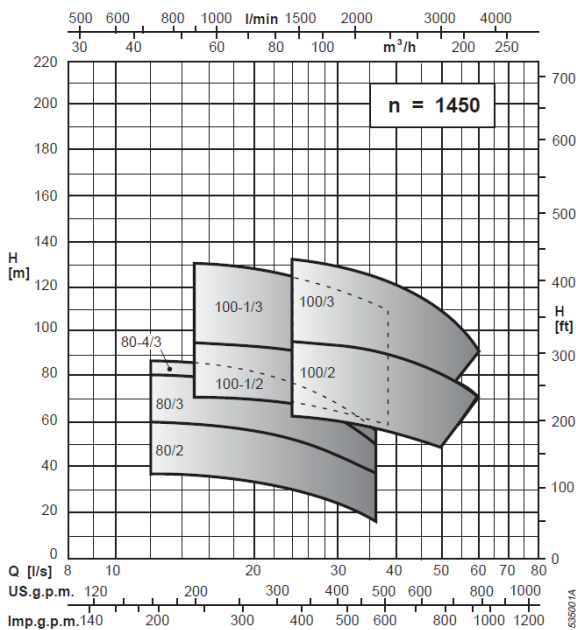

DIESEL PUMP UNITS



JO2C002KIT

JOHN DEERE ENGINE
WITH CAPRARI PUMP

CAPRARI PUMP MEC-MG 80-4/3A

GENERAL PUMP DATA

Capacity at 1450 N [min-1]

DNa x DNm	Impellers Combination	l/s	0	12	15	20	25	30	32	34	36	38
		m ³ /h	0	36	54	72	90	108	115	122	130	137
mm		l/min	0	600	900	1200	1500	1800	1920	2040	2160	2280
100 x 80	A	m	92.9	88	86	82	75	68	64	59	57	
		kW	10.8	17	18.8	21.9	24.8	25.5	28.4	29.2	29.9	
NPSH m				1.4	1.4	1.4	1.7	2.4	3	3.9	5.1	

Capacity at 1750 N [min-1]

DNa x DNm	Impellers Combination	l/s	0	14	16	18	20	24	28	32	36	40
		m ³ /h	0	50	58	65	72	86	101	115	129	144
mm		l/min	0	840	960	1080	1200	1440	1680	1920	2160	2400
100 x 80	A	m	135	128	127	125	123	119	114	107	99	89
		kW	19	29.3	31.1	32.9	34.7	38.5	42.1	44.9	47.8	50.9
NPSH m				1.7	1.7	1.7	1.7	1.9	2.3	2.8	3.7	5.3

Capacity at 2000 N [min-1]

DNa x DNm	Impellers Combination	l/s	0	16	18	20	24	28	32	36	40	45
		m ³ /h	0	58	65	72	86	101	115	129	144	162
mm		l/min	0	960	1080	1200	1440	1680	1920	2160	2400	2700
100 x 80	A	m	177	168	166	164	160	155	149	141	132	119
		kW	28.5	43.9	46	48.4	53.3	58.1	62.6	66.7	70.3	75.1
NPSH m				2	2	2	2.2	2.4	2.8	3.4	4.4	6.2



DIESEL PUMP UNITS

DIESEL PUMP UNITS

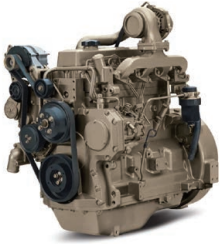

JO2C002KIT

JOHN DEERE ENGINE
WITH CAPRARI PUMP

JOHN DEERE ENGINE 4045TF250-01 GENERAL PUMP DATA

Intermittent - Rated power/Rated speed	85-93 kW (114-125 hp) @2200-2400 rpm
Intermittent - Peak torque	445-446 N·m (328-329 ft-lb) @1400-1500 rpm
Intermittent - Torque rise	NA

ENGINE PERFORMANCE RANGE

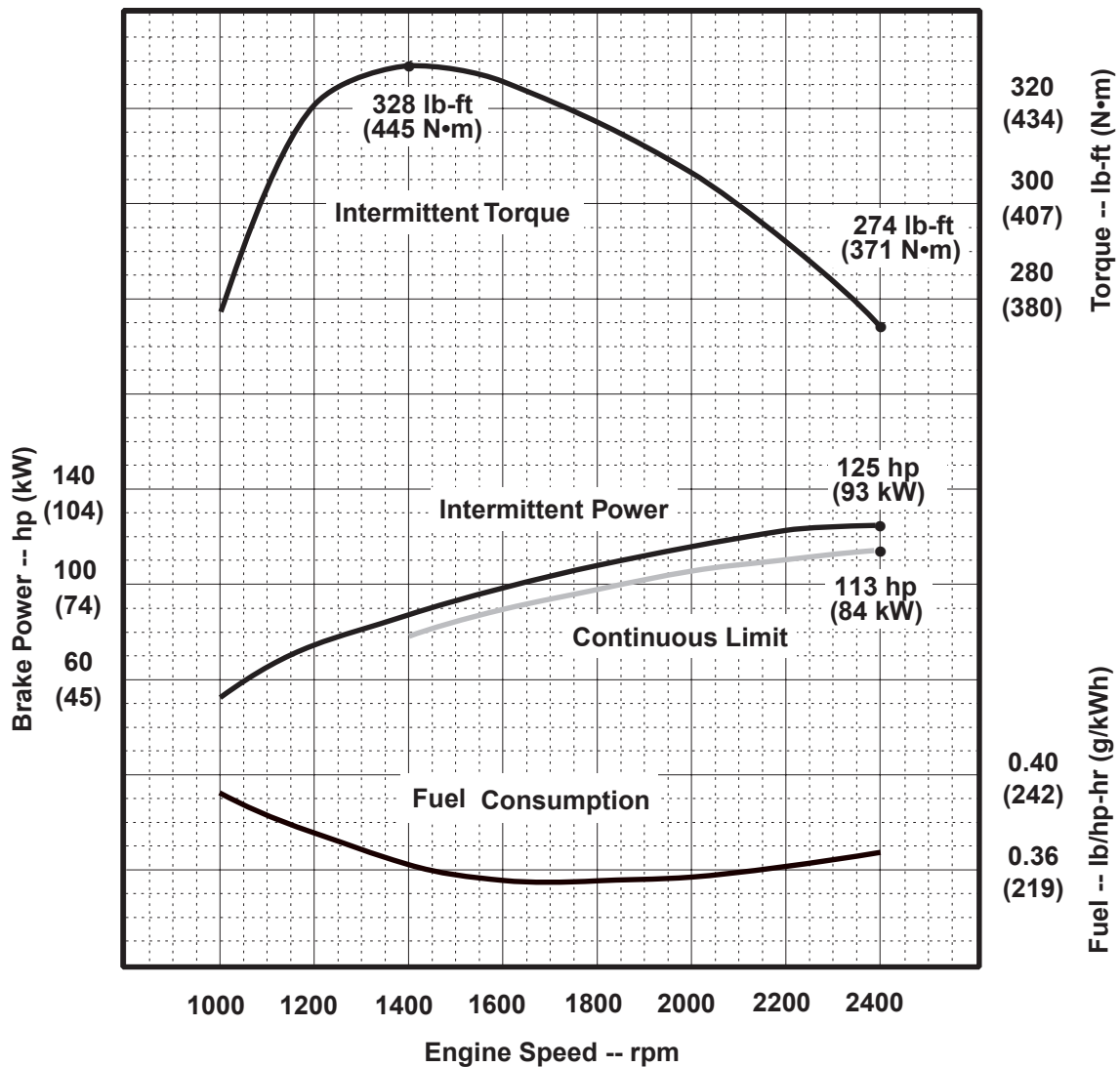

DIESEL PUMP UNITS



JOHN DEERE



J04C011KIT

JOHN DEERE ENGINE WITH CAPRARI PUMP



STANDARD EQUIPMENT

- JOHN DEERE D6068TF150-016 6 Cylinder Turbo 6800CC water-cooled diesel engine, complete with engine liquids.
- Caprari MEC MG 100HT/2A Pump.
- Mounted on two pneumatic wheels trolley, with 400 litre built in tank.
- Centrifugal flanged pump coupled to the engine through flexible joint.
- Battery.
- ELCOS CEM 250/00 control panel with electric system, engine control device, transducer for high pressure and low pressure alarm, 24 hour timer.
- ABS roof.
- Engine running indicator light on roof.
- Work light for around unit.

Code	Price
J04C011KIT	65,921.40

Machine Options	Code	Price
Priming System Kirpy	406053	1,022.90
Electric Priming Pump	EPP	2,035.20

Computer Options	Code	Price
Upgrade to Elcos CIM 131	CIM131UPGRADE	2,530.80
Upgrade to Elcos CIM 137	CIM137UPGRADE	3,483.20

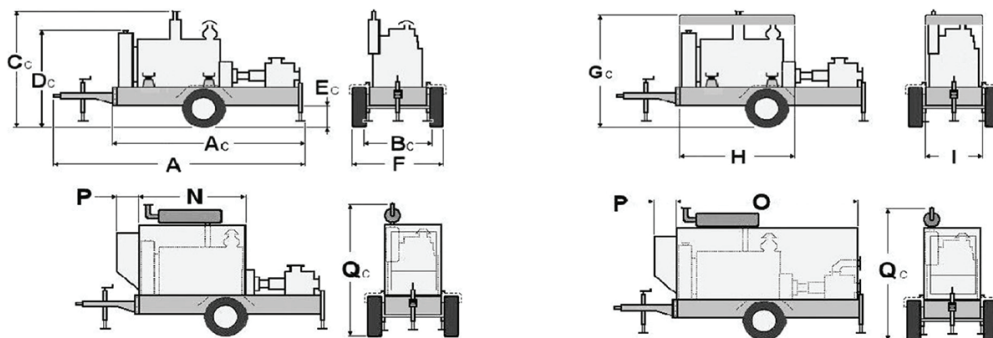

WEIGHTS AND DIMENSIONS

SIZE (cm)													
A	Ac	Bc	Cc	Dc	Ec	F	Gc	H	I	N	O	P	Qc
380.4	246	122.9	274.8	108.2	34	145	180	160	100	160	235	35	252

* Please note dimensions are to be used as a guide only.



DIESEL PUMP UNITS

DIESEL PUMP UNITS



J04C011KIT

JOHN DEERE ENGINE
WITH CAPRARI PUMP

CAPRARI PUMP MEC-MG 100HT 2A PUMP PERFORMANCE RANGE

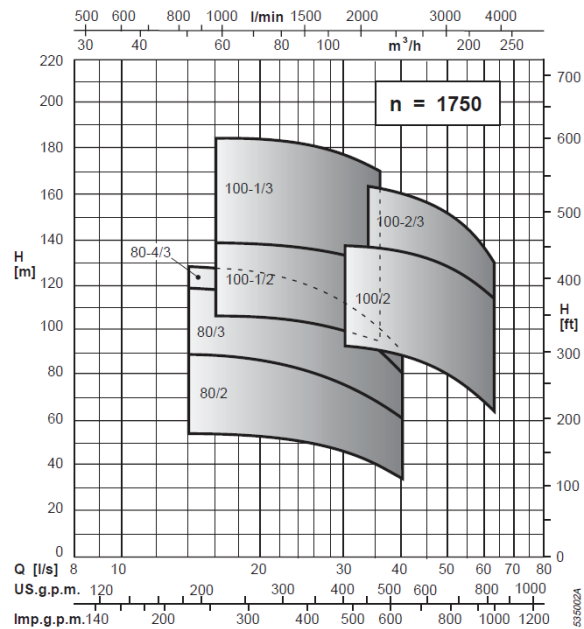
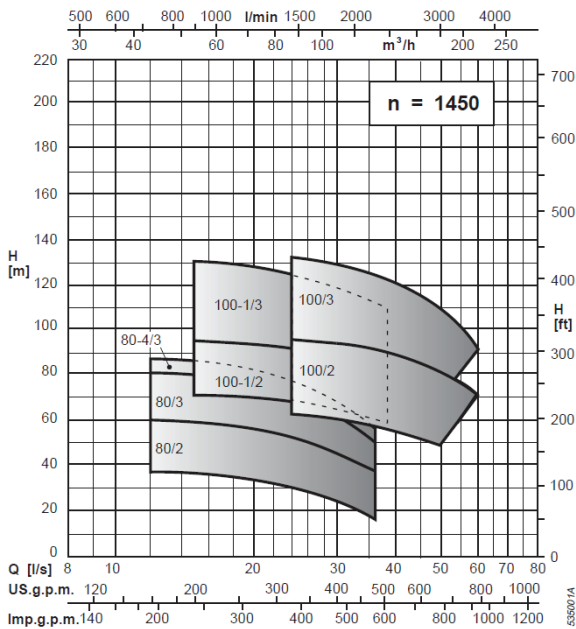

DIESEL PUMP UNITS



JOHN DEERE



J04C011KIT

JOHN DEERE ENGINE
WITH CAPRARI PUMP

CAPRARI PUMP MEC-MG 100HT 2A GENERAL PUMP DATA

Capacity at 1450 N [min⁻¹]

DNa x DNm	Impellers Combination	l/s	0	24	28	30	35	40	45	50	55	60
		m ³ /h	0	86	101	108	126	144	162	180	198	216
mm		l/min	0	1440	1680	1800	2100	2400	2700	3000	3300	3600
125 x 100	A	m	97	96	95	94	92	89	85	80	75	68
		kW	18.5	37.5	41	42	45.5	49	55	56	59	60
NPSH m				2	2	2	2	2.2	2.5	3.2	4.4	6

Capacity at 1750 N [min⁻¹]

DNa x DNm	Impellers Combination	l/s	0	30	34	38	42	46	50	54	58	62
		m ³ /h	0	108	122	137	151	165	180	194	209	223
mm		l/min	0	1800	2040	2280	2520	2760	3000	3240	3480	3720
125 x 100	A	m	136	138	137	135	132	130	127	123	119	112
		kW	32.5	69	73.5	78	80	82	87	90	97	100
NPSH m				2.3	2.4	2.5	2.7	3	3.4	4	4.7	5.4



DIESEL PUMP UNITS

DIESEL PUMP UNITS

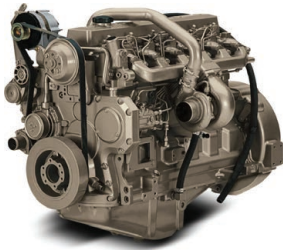

J04C011KIT

JOHN DEERE ENGINE
WITH CAPRARI PUMP

JOHN DEERE ENGINE D6068TF150-016

GENERAL ENGINE DATA

Intermittent - Rated power/Rated speed	110.5-127 kW (148-170 hp) @2100-2500 rpm
Intermittent - Peak torque	600-606 N·m (443-447 ft-lb) @1200-1400 rpm
Intermittent - Torque rise	NA

ENGINE PERFORMANCE RANGE

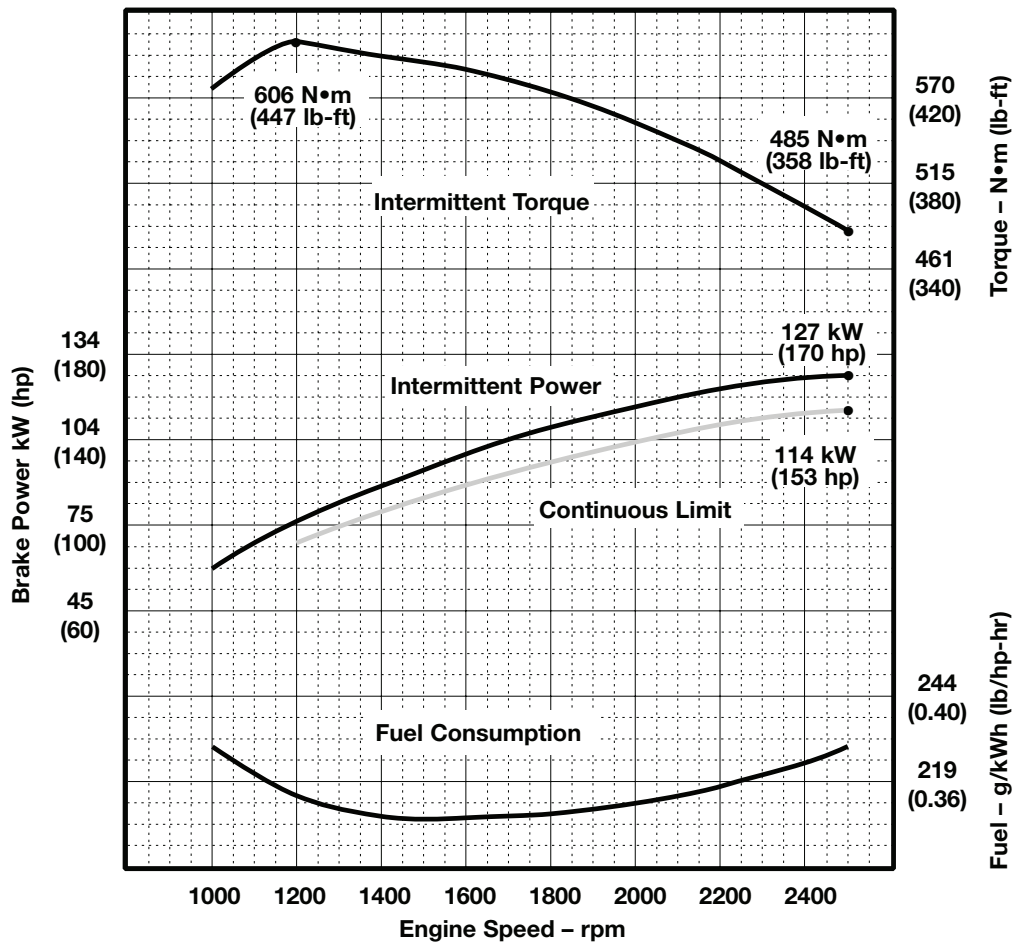

DIESEL PUMP UNITS



K08R715KIT

PERKINS ON TROLLEY WITH ROVATTI PUMP



STANDARD EQUIPMENT

- 4 cylinder air-cooled engine, complete with engine liquids and fuel tank.
- Rovatti F43K80/4H Pump.
- Mounted on two pneumatic wheels trolley, with 60 built in tank.
- Flanged Centrifugal PUMP.
- Electric start with key block and battery.
- PERKINS: ELCOS CEM 250/00 control panel with electric system, engine control device, pressure gauge, pressure switch, 24 hour timer.
- Battery.
- ABS Roof.
- Engine running indicator light.
- Work light for around unit.

Code	Price
K08R715KIT	37,380.90

Machine Options	Code	Price
Priming System Kirpy	406053	1,022.90
Electric Priming Pump	EPP	2,035.20

Computer Options	Code	Price
Upgrade to Elcos CIM 131	CIM131UPGRADE	2,530.80
Upgrade to Elcos CIM 137	CIM137UPGRADE	3,483.20

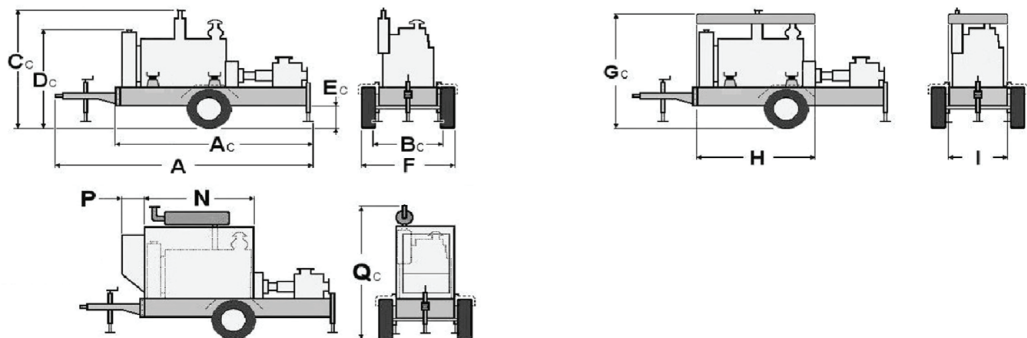

WEIGHTS AND DIMENSIONS

SIZE (cm)												
A	Ac	Bc	Cc	Dc	Ec	F	Gc	H	I	N	P	Qc
315.0	181.0	122.9	193.7	174.2	28.0	137.0	174.0	130.0	100.0	128.0	40.0	222.0

* Please note dimensions are to be used as a guide only.



DIESEL PUMP UNITS



K08R715KIT

JOHN DEERE ENGINE
WITH ROVATTI PUMP

DIESEL PUMP UNITS

ROVATTI PUMP F43K80/4H PUMP PERFORMANCE RANGE

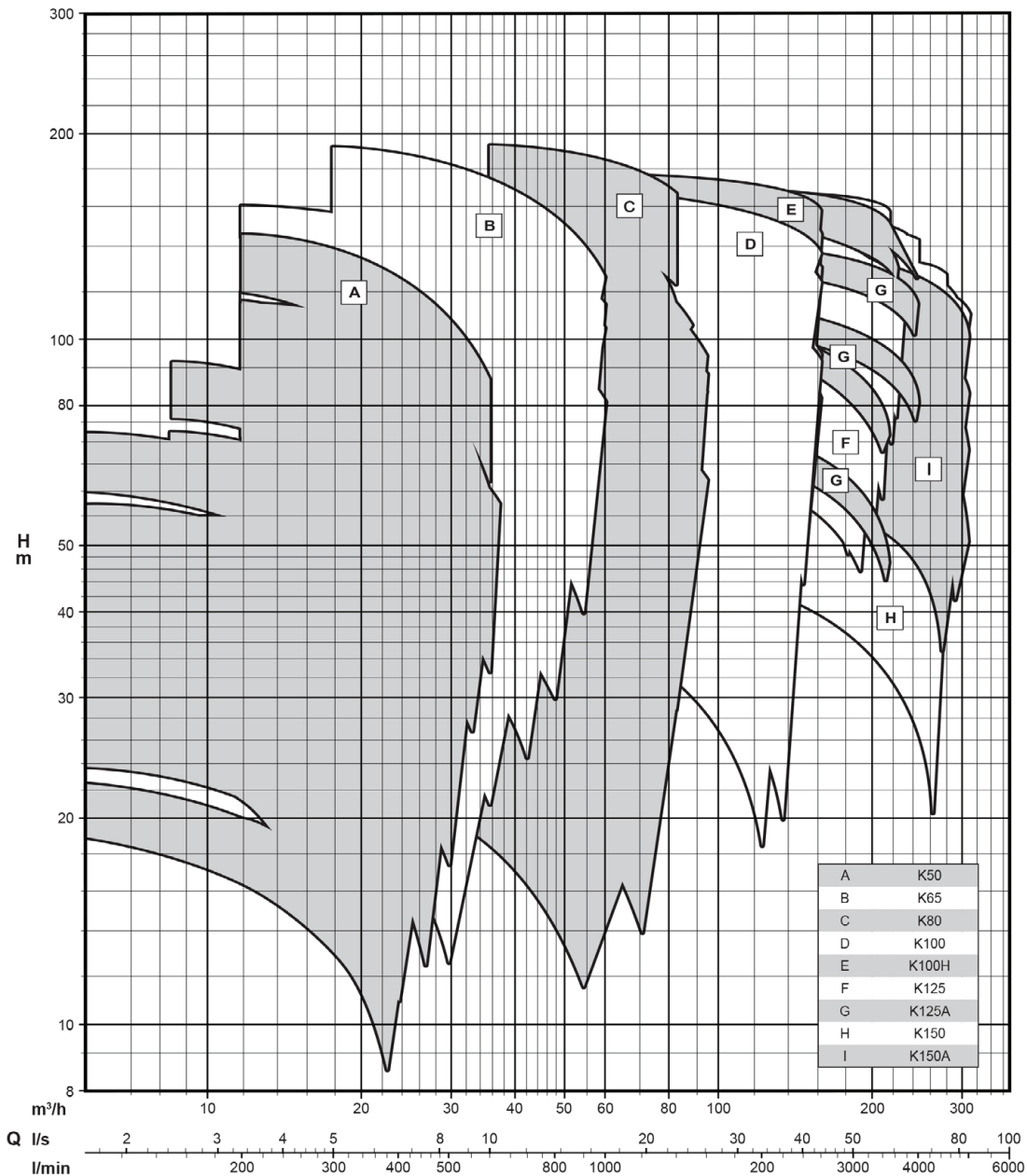

DIESEL PUMP UNITS



K08R715KIT

JOHN DEERE ENGINE
WITH CAPRARI PUMP

ROVATTI PUMP F43K80/4H GENERAL PUMP DATA

DNa x DNm	Impellers Combination	l/s	0	8.3	10	11.7	13.3	15	16.7	18.3	20	21.7	23.3	25
		m ³ /h	0	30	36	42	48	54	60	66	72	78	84	90
mm		l/min	0	500	600	700	800	900	1000	1100	1200	1300	1400	1500

Capacity at 1450 N [min-1]

80 x 65	H	m	58.5	55	52.2	49	44.7	39.7	33.6	27	19.3	
		KW	4.1	7.2	7.2	8.2	8.6	9	9.3	9.6	9.7	
NPSH m			-	2.5	2.6	2.7	2.9	3.1	3.5	4.2	5.0	

Capacity at 1800 N [min-1]

80 x 65	H	m	90.8	87	85	82	78	73.6	68	61.3	54	46
		KW	7.7	12.3	13.3	14.2	15.1	1.8	16.6	17.2	17.8	18.2
NPSH m			-	2.5	2.55	2.65	2.75	2.9	3.2	3.55	4.05	4.65

Capacity at 2000 N [min-1]

80 x 65	H	m	111.3	108	106	103	100	95.5	90.3	84	77	69.5	61
		KW	8.9	16	17.2	18.4	19.7	20.6	21.6	22.6	23.4	23.9	24.3
NPSH m			-	2.5	2.55	2.65	2.75	2.85	3.1	3.4	3.7	4.15	4.7

Capacity at 2300 N [min-1]

80 x 65	H	m	146.8	44	143	141	138	134	129	123	116	109	101	93
		kW	14.8	23.6	25.2	26.9	28.5	30	31.5	32.8	34.1	35.2	36.1	36.8
NPSH m			-	2.5	2.5	2.55	2.6	2.8	3	3.2	3.5	3.9	4.3	4.9



DIESEL PUMP UNITS

DIESEL PUMP UNITS



K08R715KIT

JOHN DEERE ENGINE
WITH CAPRARI PUMP

PERKINS MOTORS 404D-22 IOPU GENERAL ENGINE DATA

Intermittent - Rated power/Rated speed	
Intermittent - Peak torque	
Intermittent - Torque rise	

ENGINE PERFORMANCE RANGE

404D-22 IOPU

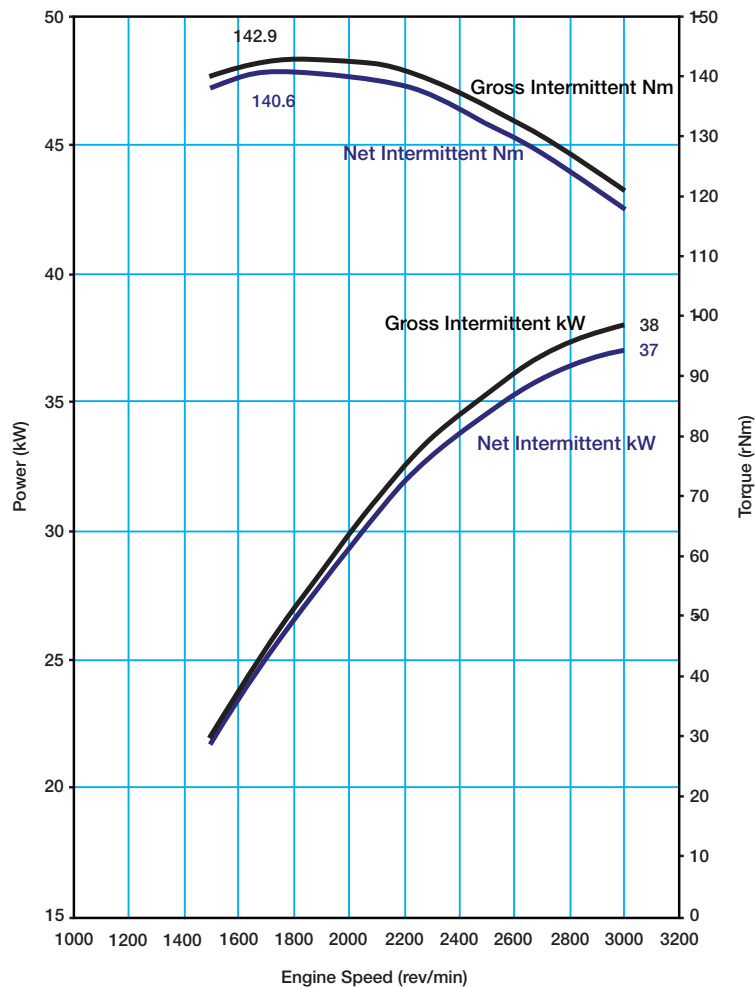

DIESEL PUMP UNITS



I75C001KIT

IVECO MOTORS SERIES NEF WITH CAPRARI PUMP



STANDARD EQUIPMENT

- 4 cylinder water-cooled IVECO MOTORS diesel engine, complete with engine liquids.
- Caprari MEC-MG 80/3G Pump.
- Mounted on two pneumatic wheels trolley, with 360 litre built in tank.
- Centrifugal flanged pump coupled to the engine through flexible joint.
- Battery.
- ELCOS CEM 250/00 control panel with electric system, engine control device, transducer for high pressure and low pressure alarm, 24 hour timer.
- Control board mod. CIM 130 FPT for ENTA engines.
- ABS roof.
- Engine running indicator light on roof.
- Work light for around unit.

Code	Price
I75C001KIT	43,523.60

Machine Options	Code	Price
Priming System Kirpy	406053	1,022.90
Electric Priming Pump	EPP	2,035.20

Computer Options	Code	Price
Upgrade to Elcos CIM 131	CIM131UPGRADE	2,530.80
Upgrade to Elcos CIM 137	CIM137UPGRADE	3,483.20

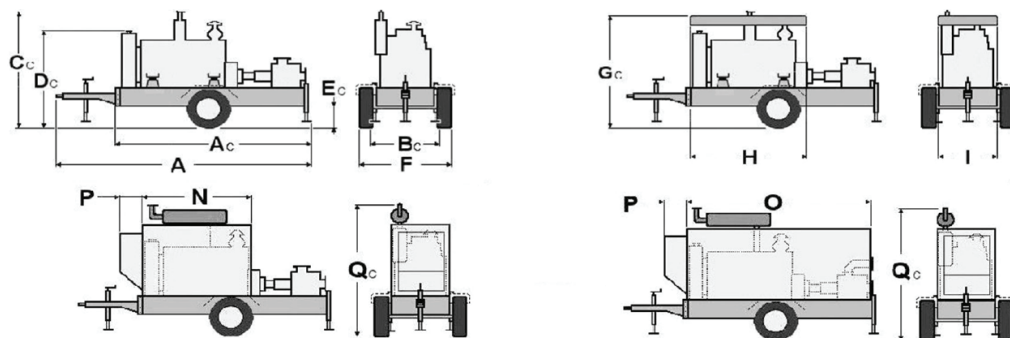

WEIGHTS AND DIMENSIONS

SIZE (cm)													
A	Ac	Bc	Cc	Dc	Ec	F	Gc	H	I	N	O	P	Qc
345.9	211.5	122.9	229.6	150.6	34	145	180	130	100	128	200	40	227.5

* Please note dimensions are to be used as a guide only.



DIESEL PUMP UNITS

DIESEL PUMP UNITS



I75C001KIT

IVECO MOTORS SERIES NEF
WITH CAPRARI PUMP

CAPRARI PUMP MEC-MG 80/3G PUMP PERFORMANCE RANGE

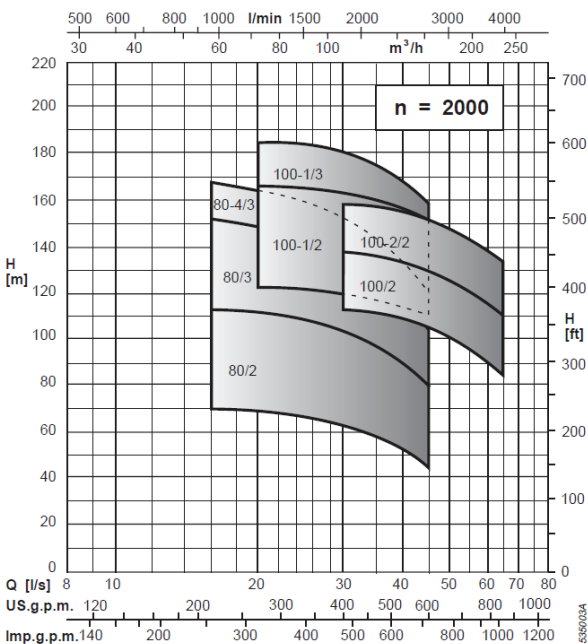
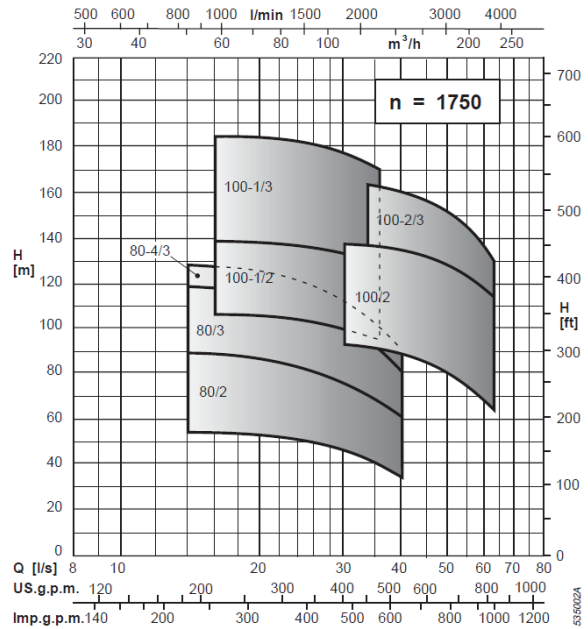
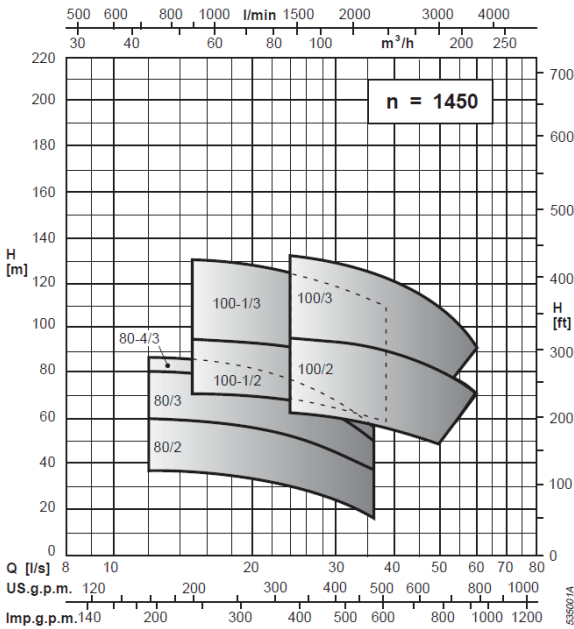

DIESEL PUMP UNITS



I75C001KIT

IVECO MOTORS SERIES NEF
WITH CAPRARI PUMP

CAPRARI PUMP MEC-MG 80/3G

GENERAL PUMP DATA

Capacity at 1450 N [min-1]

DNa x DNm	Impellers Combination	l/s	0	12	15	20	25	30	32	34	36	38
		m ³ /h	0	36	54	72	90	108	115	122	130	137
mm		l/min	0	600	900	1200	1500	1800	1920	2040	2160	2280
100 x 80	G	m	65	66	63	58	51	42.5	38.5	34.5	30	
		KW	9.1	11.8	13.5	16	18	20	20.5	21	21.5	
NPSH m				1,8	2	2.2	3.6	4.6	5.1	6	7	

Capacity at 1750 N [min-1]

DNa x DNm	Impellers Combination	l/s	0	14	16	18	20	24	28	32	36	40
		m ³ /h	0	50	58	65	72	86	101	115	129	144
mm		l/min	0	840	960	1080	1200	1440	1680	1920	2160	2400
100 X 80	G	m	98	99	98	95	93	86	80	71	62	
		KW	16	22.5	24	25.5	27.5	30	32.5	34.5	35.5	
NPSH m				2.1	2.1	2.2	2.3	2.5	2.8	3.3	4.3	6

Capacity at 2000 N [min-1]

DNa x DNm	Impellers Combination	l/s	0	16	18	20	24	28	32	36	40	45
		m ³ /h	0	58	65	72	86	101	115	129	144	162
mm		l/min	0	960	1080	1200	1440	1680	1920	2160	2400	2700
100 X 80	G	m	129	130	128	126	121	114	106	98	87	
		KW	24	32.5	36.5	38	38.5	45	47.5	50	50.5	
NPSH m				2.3	2.3	2.4	2.6	2.8	3.1	3.6	4.4	6.3



DIESEL PUMP UNITS

DIESEL PUMP UNITS

I75C001KIT

IVECO MOTORS SERIES NEF
WITH CAPRARI PUMP



IVECO MOTORS SERIES NEF F32MNSX00 GENERAL ENGINE DATA

Intermittent - Rated power/Rated speed	
Intermittent - Peak torque	
Intermittent - Torque rise	

55 kW (75 Hp) @ 2500 rpm

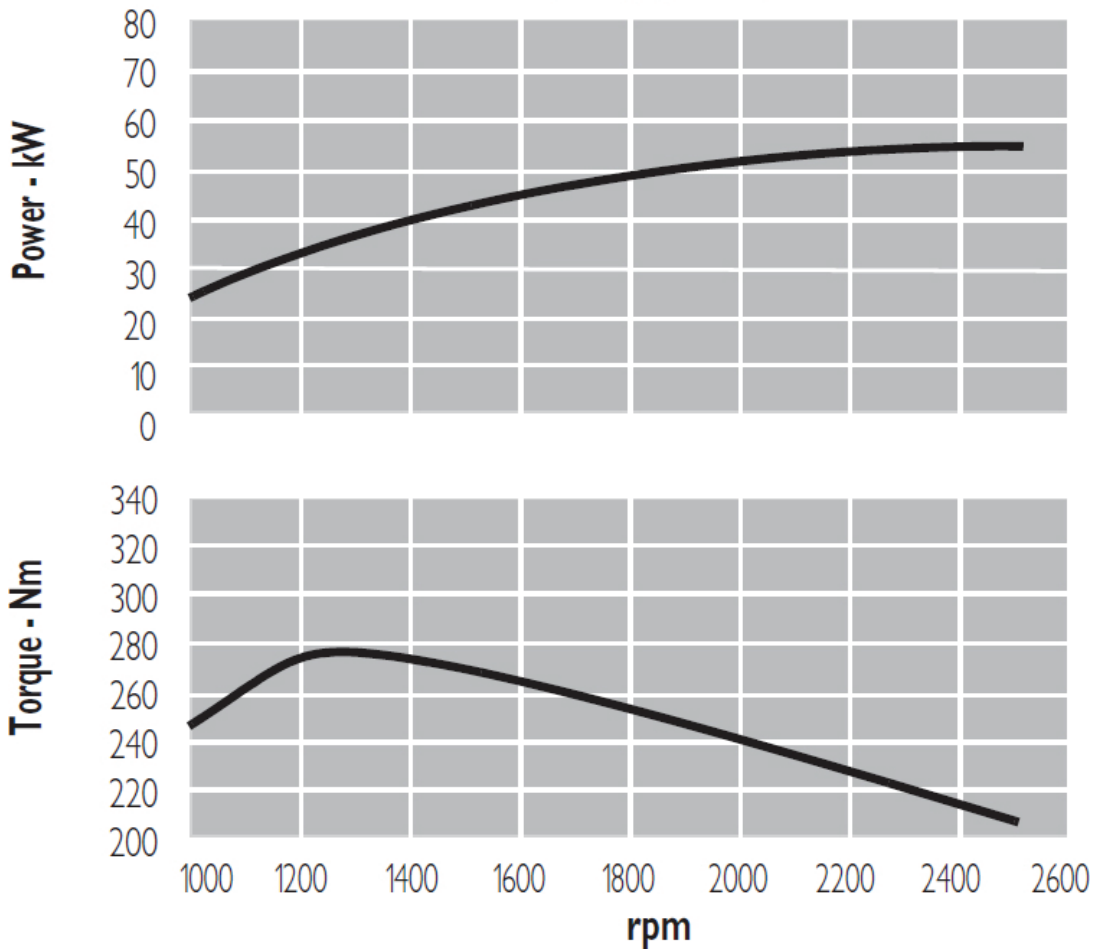

DIESEL PUMP UNITS



I26C001KIT

IVECO MOTORS SERIES NEF WITH CAPRARI PUMP



STANDARD EQUIPMENT

- 4 cylinder water-cooled IVECO MOTORS diesel engine, complete with engine liquids.
- Caprari MEG-MG 80/3G Pump.
- Mounted on two pneumatic wheels trolley, with 360 litre built in tank.
- Centrifugal flanged pump coupled to the engine through flexible joint.
- Battery.
- ELCOS CEM 250/00 control panel with electric system, engine control device, transducer for high pressure and low pressure alarm, 24 hour timer.
- Control board mod. CIM 130 FPT for ENTA engines.
- ABS roof.
- Engine running indicator light on roof.
- Work light for around unit.

Code	Price
I26C001KIT	47,260.10

Machine Options	Code	Price
Priming System Kirpy	406053	1,022.90
Electric Priming Pump	EPP	2,035.20

Computer Options	Code	Price
Upgrade to Elcos CIM 131	CIM131UPGRADE	2,530.80
Upgrade to Elcos CIM 137	CIM137UPGRADE	3,483.20

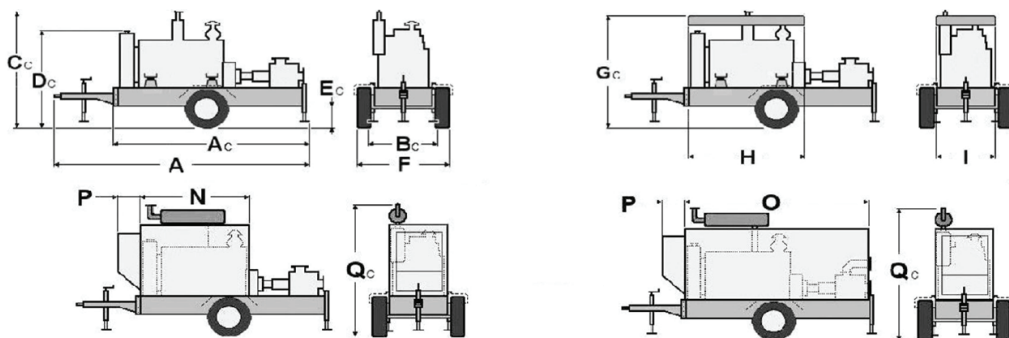

WEIGHTS AND DIMENSIONS

SIZE (cm)													
A	Ac	Bc	Cc	Dc	Ec	F	Gc	H	I	N	O	P	Qc
345.9	211.5	122.9	229.6	160.6	34	145	180	130	100	128	200	40	227.5

* Please note dimensions are to be used as a guide only.



DIESEL PUMP UNITS

DIESEL PUMP UNITS



I26C001KIT IVECO MOTORS SERIES NEF WITH CAPRARI PUMP

CAPRARI PUMP MEC-MG 80/3G PUMP PERFORMANCE RANGE

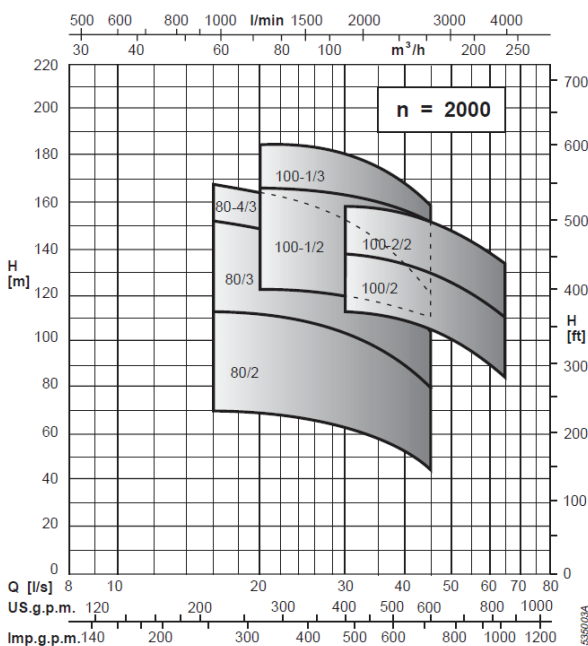
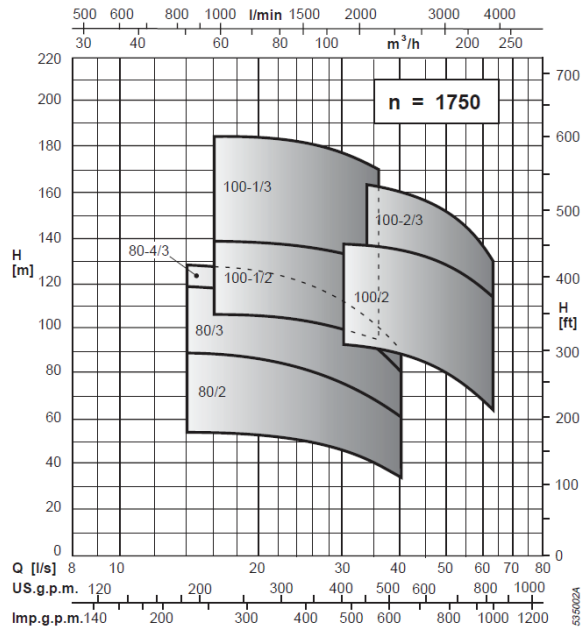
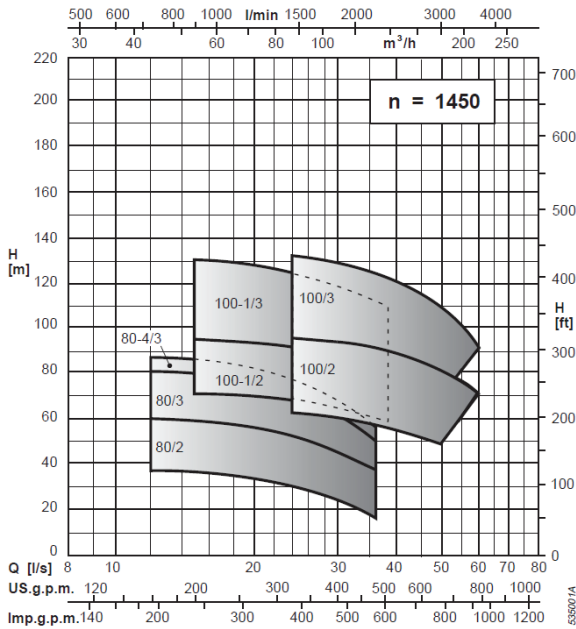

DIESEL PUMP UNITS



I26C001KIT

IVECO MOTORS SERIES NEF
WITH CAPRARI PUMP

CAPRARI PUMP MEC-MG 80/3G GENERAL PUMP DATA

Capacity at 1450 N [min-1]

DNa x DNm	Impellers Combination	l/s	0	12	15	20	25	30	32	34	36	38
		m ³ /h	0	36	54	72	90	108	115	122	130	137
mm		l/min	0	600	900	1200	1500	1800	1920	2040	2160	2280
100 x 80	G	m	65	66	63	58	51	42.5	38.5	34.5	30	
		KW	9.1	11.8	13.5	16	18	20	20.5	21	21.5	
NPSH m				1,8	2	2.2	3.6	4.6	5.1	6	7	

Capacity at 1750 N [min-1]

DNa x DNm	Impellers Combination	l/s	0	14	16	18	20	24	28	32	36	40
		m ³ /h	0	50	58	65	72	86	101	115	129	144
mm		l/min	0	840	960	1080	1200	1440	1680	1920	2160	2400
100 X 80	G	m	98	99	98	95	93	86	80	71	62	
		KW	16	22.5	24	25.5	27.5	30	32.5	34.5	35.5	
NPSH m				2.1	2.1	2.2	2.3	2.5	2.8	3.3	4.3	6

Capacity at 2000 N [min-1]

DNa x DNm	Impellers Combination	l/s	0	16	18	20	24	28	32	36	40	45
		m ³ /h	0	58	65	72	86	101	115	129	144	162
mm		l/min	0	960	1080	1200	1440	1680	1920	2160	2400	2700
100 X 80	G	m	129	130	128	126	121	114	106	98	87	
		KW	24	32.5	36.5	38	38.5	45	47.5	50	50.5	
NPSH m				2.3	2.3	2.4	2.6	2.8	3.1	3.6	4.4	6.3



DIESEL PUMP UNITS

DIESEL PUMP UNITS

I26C001KIT

IVECO MOTORS SERIES NEF
WITH CAPRARI PUMP



IVECO MOTORS SERIES N45MSAA00 GENERAL ENGINE DATA

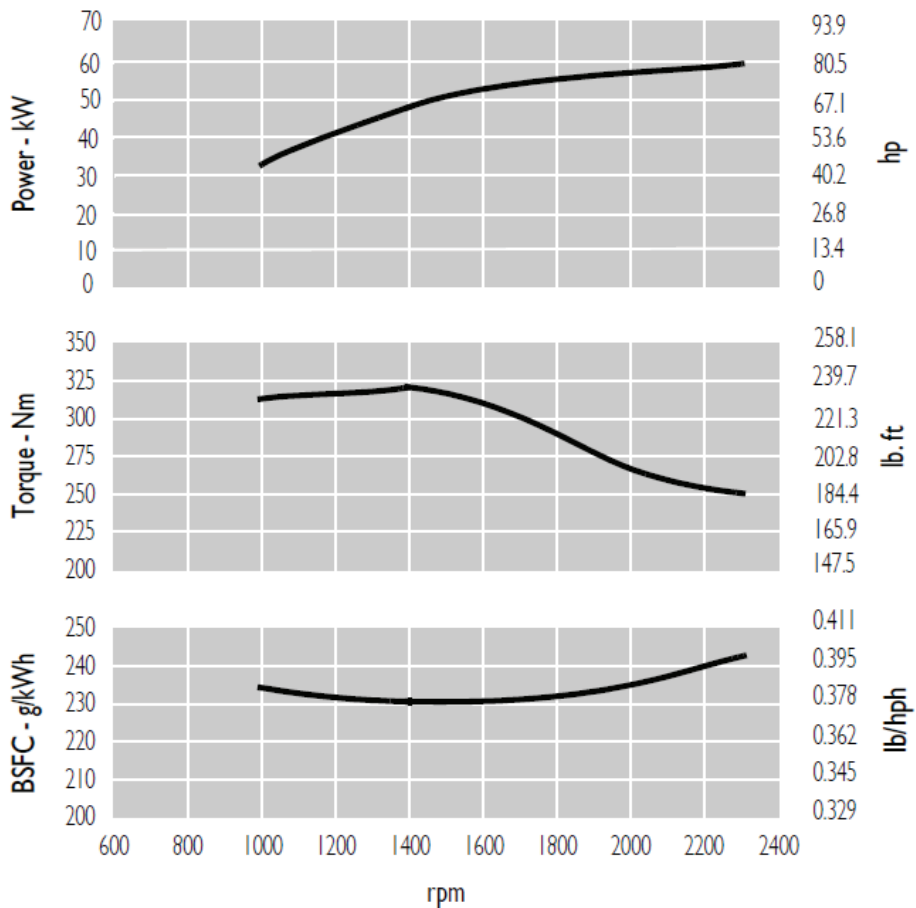

DIESEL PUMP UNITS



I73C002KIT

IVECO MOTORS SERIES NEF WITH CAPRARI PUMP



STANDARD EQUIPMENT

- 4 cylinder Turbo water-cooled IVECO MOTORS diesel engine, complete with engine liquids.
- Caprari MEC-MG 80-4/3A Pump.
- Mounted on two pneumatic wheels trolley, with 360 litre built in tank.
- Centrifugal flanged pump coupled to the engine through flexible joint.
- Battery.
- ELCOS CEM 250/00 control panel with electric system, engine control device, transducer for high pressure and low pressure alarm, 24 hour timer.
- Control board mod. CIM 130 FPT for ENTA engines.
- ABS roof.
- Engine running indicator light on roof.
- Work light for around unit.

Code	Price
I73C002KIT	57,202.90

Machine Options	Code	Price
Priming System Kirpy	406053	1,022.90
Electric Priming Pump	EPP	2,035.20

Computer Options	Code	Price
Upgrade to Elcos CIM 131	CIM131UPGRADE	2,530.80
Upgrade to Elcos CIM 137	CIM137UPGRADE	3,483.20

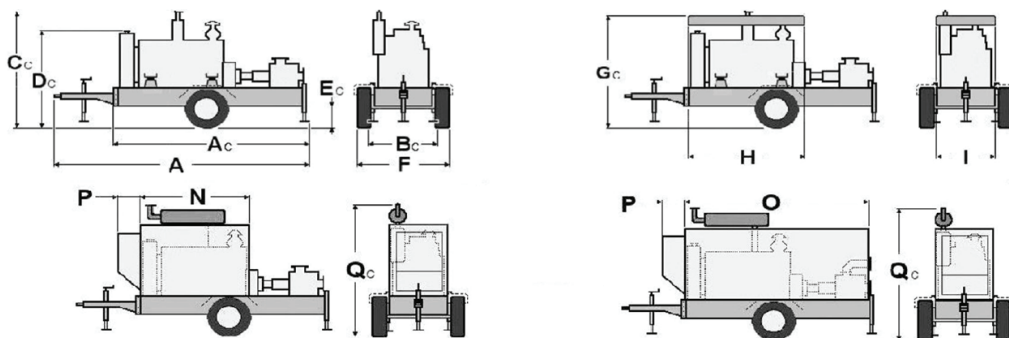

WEIGHTS AND DIMENSIONS

SIZE (cm)													
A	Ac	Bc	Cc	Dc	Ec	F	Gc	H	I	N	O	P	Qc
345.9	211.5	122.9	239.6	160.6	34	145	180	130	100	128	200	40	227.5

* Please note dimensions are to be used as a guide only.



DIESEL PUMP UNITS

DIESEL PUMP UNITS



I73C002KIT

JOHN DEERE ENGINE
WITH CAPRARI PUMP

CAPRARI PUMP MEC-MG 80-4/3A PUMP PERFORMANCE RANGE

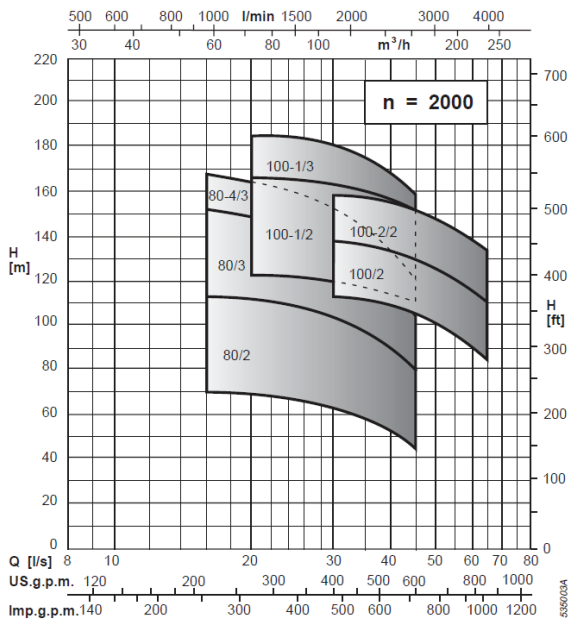
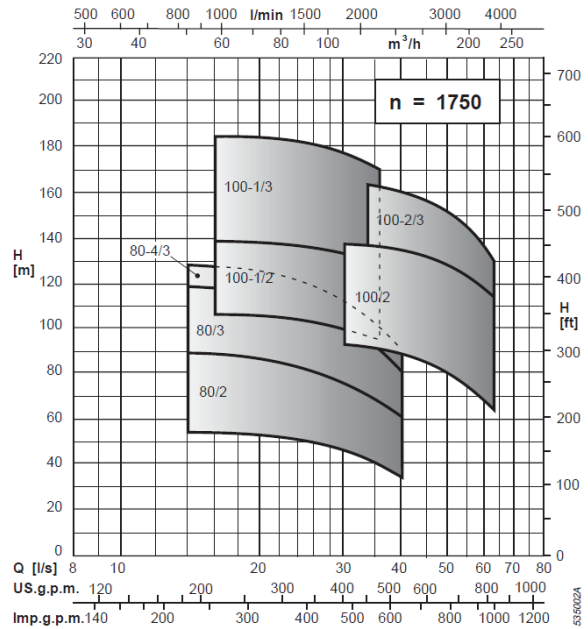
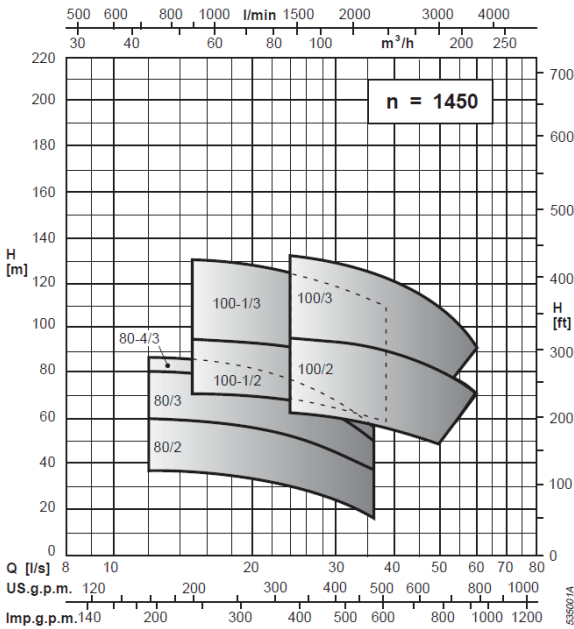

DIESEL PUMP UNITS



I73C002KIT

IVECO MOTORS SERIES NEF
WITH CAPRARI PUMP

CAPRARI PUMP MEC-MG 80-4/3A

GENERAL PUMP DATA

Capacity at 1450 N [min-1]

DNa x DNm	Impellers Combination	l/s	0	12	15	20	25	30	32	34	36	38
		m ³ /h	0	36	54	72	90	108	115	122	130	137
mm		l/min	0	600	900	1200	1500	1800	1920	2040	2160	2280
100 x 80	A	m	92.9	88	86	82	75	68	64	59	57	
		kW	10.8	17	18.8	21.9	24.8	25.5	28.4	29.2	29.9	
NPSH m				1.4	1.4	1.4	1.7	2.4	3	3.9	5.1	

Capacity at 1750 N [min-1]

DNa x DNm	Impellers Combination	l/s	0	14	16	18	20	24	28	32	36	40
		m ³ /h	0	50	58	65	72	86	101	115	129	144
mm		l/min	0	840	960	1080	1200	1440	1680	1920	2160	2400
100 x 80	A	m	135	128	127	125	123	119	114	107	99	89
		kW	19	29.3	31.1	32.9	34.7	38.5	42.1	44.9	47.8	50.9
NPSH m				1.7	1.7	1.7	1.7	1.9	2.3	2.8	3.7	5.3

Capacity at 2000 N [min-1]

DNa x DNm	Impellers Combination	l/s	0	16	18	20	24	28	32	36	40	45
		m ³ /h	0	58	65	72	86	101	115	129	144	162
mm		l/min	0	960	1080	1200	1440	1680	1920	2160	2400	2700
100 x 80	A	m	177	168	166	164	160	155	149	141	132	119
		kW	28.5	43.9	46	48.4	53.3	58.1	62.6	66.7	70.3	75.1
NPSH m				2	2	2	2.2	2.4	2.8	3.4	4.4	6.2



DIESEL PUMP UNITS

DIESEL PUMP UNITS

I73C002KIT

IVECO MOTORS SERIES NEF
WITH CAPRARI PUMP



IVECO MOTORS SERIES N45MSTX20 ENGINE PERFORMANCE RANGE

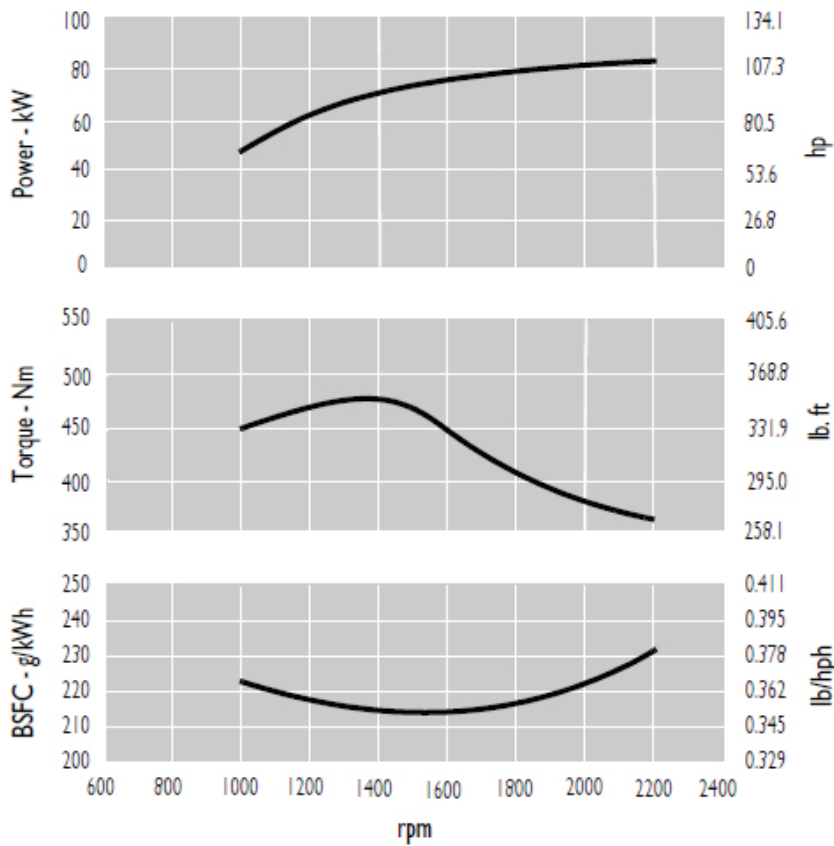

DIMENSIONS

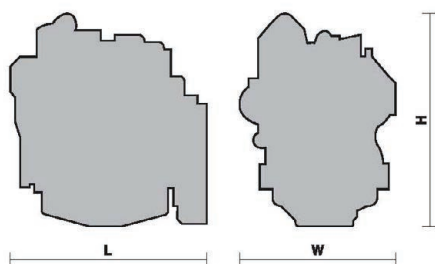

L	807mm
W	600mm
H	972mm

DIESEL PUMP UNITS



I15C011KIT

IVECO MOTORS SERIES NEF WITH CAPRARI PUMP



STANDARD EQUIPMENT

- 6 cylinder Turbo water-cooled IVECO MOTORS diesel engine, complete with engine liquids.
- Caprari MEC-BG 100HT 2A Pump.
- Mounted on two pneumatic wheels trolley, with 400 litre built in tank.
- Centrifugal flanged pump coupled to the engine through flexible joint.
- Battery.
- ELCOS CEM 250/00 control panel with electric system, engine control device, transducer for high pressure and low pressure alarm, 24 hour timer.
- Control board mod. CIM 130 FPT for ENTA engines.
- ABS roof.
- Engine running indicator light on roof.
- Work light for around unit.

Code	Price
I73C002KIT	57,202.90

Machine Options	Code	Price
Priming System Kirpy	406053	1,022.90
Electric Priming Pump	EPP	2,035.20

Computer Options	Code	Price
Upgrade to Elcos CIM 131	CIM131UPGRADE	2,530.80
Upgrade to Elcos CIM 137	CIM137UPGRADE	3,483.20

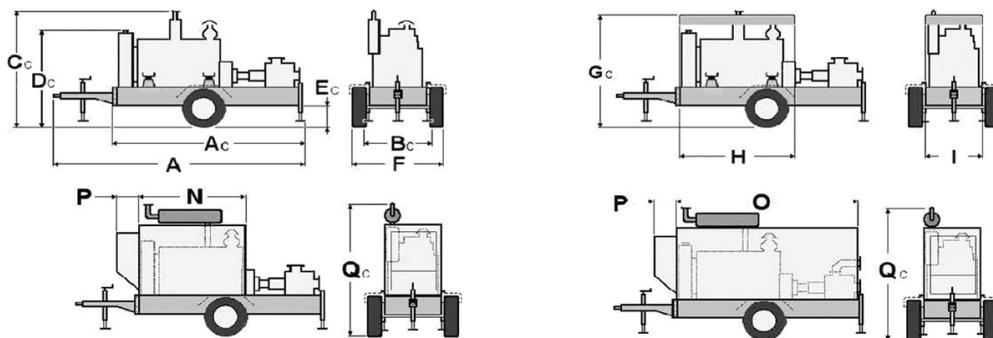

WEIGHTS AND DIMENSIONS

SIZE (cm)													
A	Ac	Bc	Cc	Dc	Ec	F	Gc	H	I	N	O	P	Qc
380.4	246	122.9	274.8	108.2	34	145	180	160	100	160	235	35	252

* Please note dimensions are to be used as a guide only.



DIESEL PUMP UNITS

DIESEL PUMP UNITS



I15C011KIT

IVECO MOTORS SERIES NEF
WITH CAPRARI PUMP

CAPRARI PUMP MEC-MG 100HT 2A

PUMP PERFORMANCE RANGE

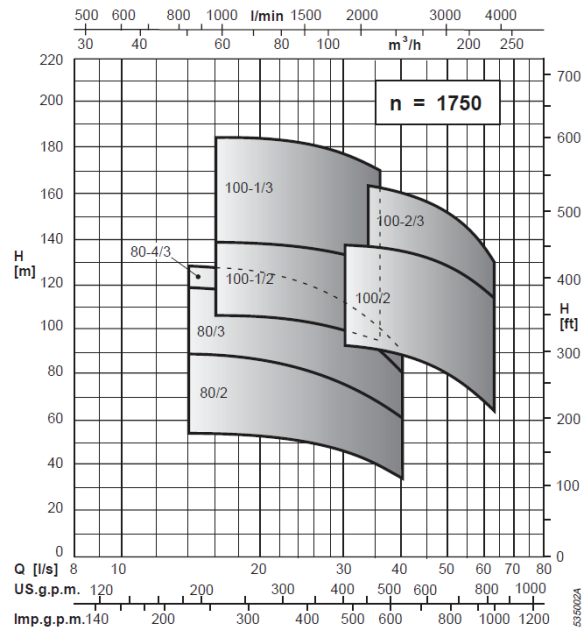
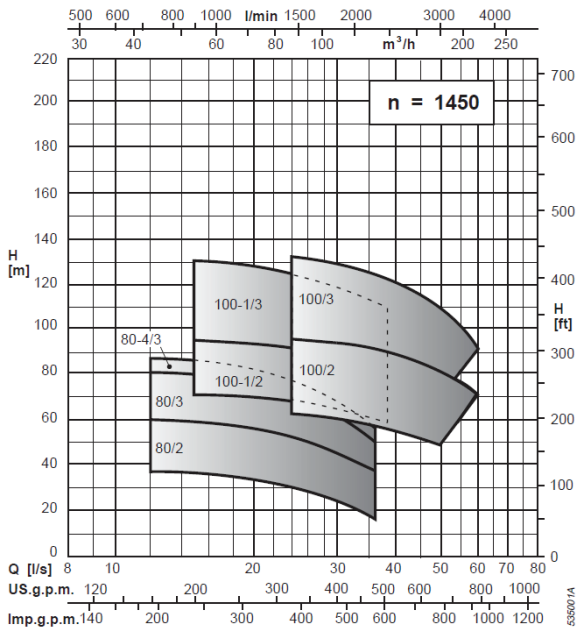

DIESEL PUMP UNITS



15C011KIT

IVECO MOTORS SERIES NEF
WITH CAPRARI PUMP

CAPRARI PUMP MEC-MG 100HT 2A GENERAL PUMP DATA

Capacity at 1450 N [min-1]

DNa x DNm	Impellers Combination	l/s	0	24	28	30	35	40	45	50	55	60
		m ³ /h	0	86	101	108	126	144	162	180	198	216
mm		l/min	0	1440	1680	1800	2100	2400	2700	3000	3300	3600
125 x 100	A	m	97	96	95	94	92	89	85	80	75	68
		kW	18.5	37.5	41	42	45.5	49	55	56	59	60
NPSH m				2	2	2	2	2.2	2.5	3.2	4.4	6

Capacity at 1750 N [min-1]

DNa x DNm	Impellers Combination	l/s	0	30	34	38	42	46	50	54	58	62
		m ³ /h	0	108	122	137	151	165	180	194	209	223
mm		l/min	0	1800	2040	2280	2520	2760	3000	3240	3480	3720
125 x 100	A	m	136	138	137	135	132	130	127	123	119	112
		kW	32.5	69	73.5	78	80	82	87	90	97	100
NPSH m				2.3	2.4	2.5	2.7	3	3.4	4	4.7	5.4



DIESEL PUMP UNITS

I15C011KIT

IVECO MOTORS SERIES NEF
WITH CAPRARI PUMP

IVECO MOTORS SERIES N67MSTD23 ENGINE PERFORMANCE RANGE

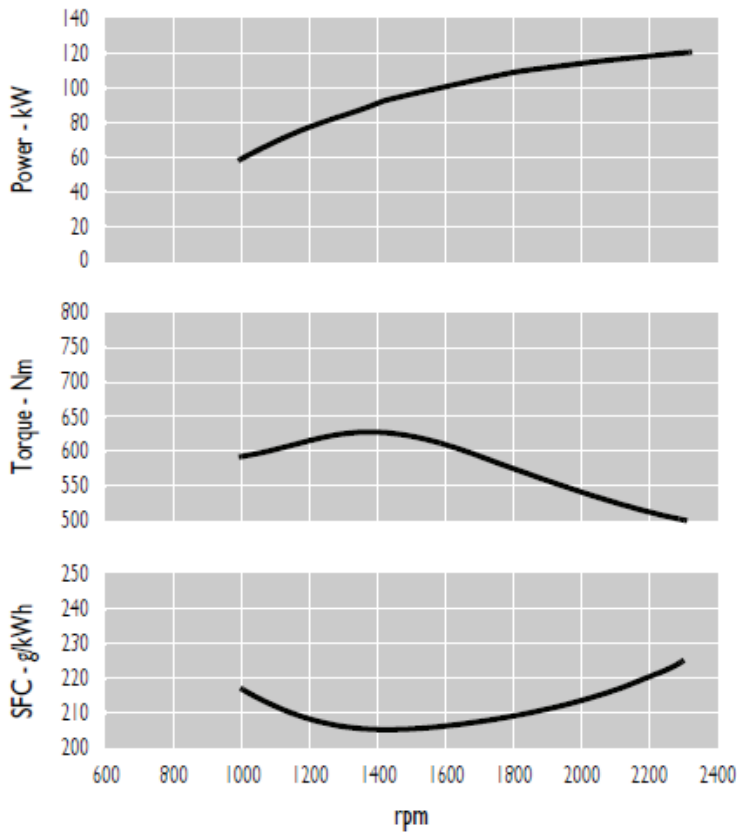

DIMENSIONS

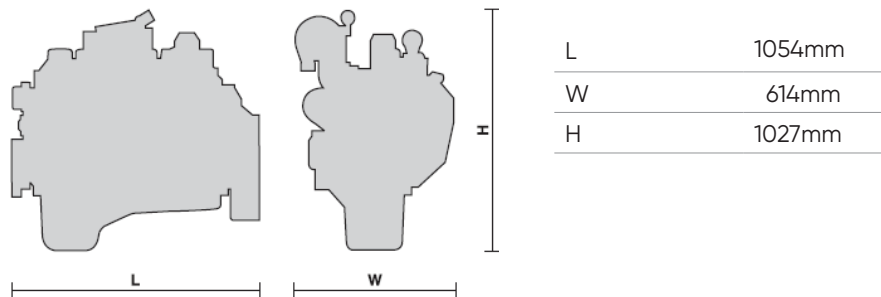



CENTRIFUGAL PUMPS



THE RANGE



MAT83/2



MAT83/2 PLUS



MAT120 PLUS



MAT125

CENTRIFUGAL PUMPS

MAT83/2



STANDARD EQUIPMENT

- Power Take Off for Water
- 3 Point Linkage
- 1: 6.3 Ratio

Description	Code	Price
Pump Centrifugal MAT83/2	LPMA832	5,490.80

SUITABLE RATIOS	IMPELLER R.P.M.	CAPACITY	PUMP HEAD (MT)	ABSORBED POWER (HP)
1: 6.3	2600	500	133	27.5
		1000	125	42
		1500	100	53
		1750	73	57
	3000	500	154	33.5
		1000	147	49
		1500	123	63
		1750	99	69
	3200	500	174	40
		1000	168	66
		1500	147	82.5
		1750	126	

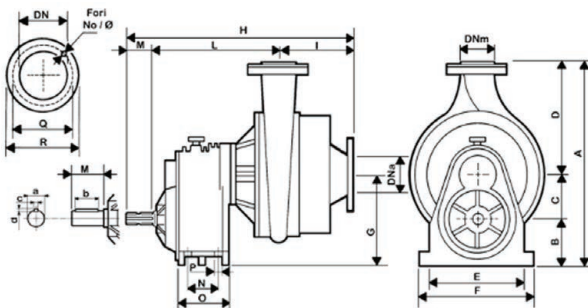
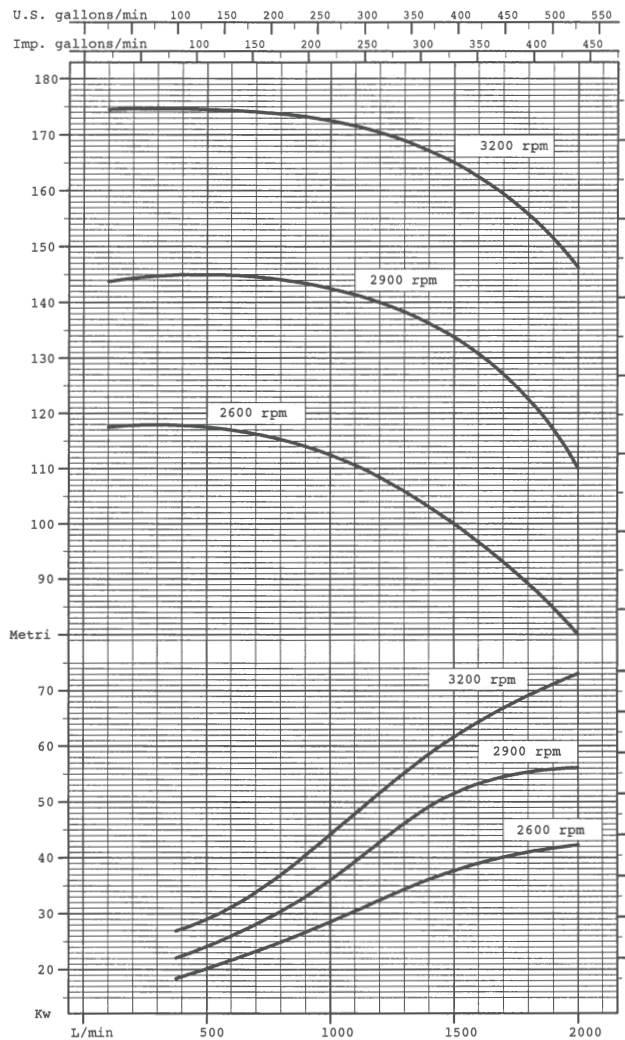

DIMENSIONS

SIZE (cm)															
A	B	C	D	E	F	G	H	I	L	M	N	O	P	Q	
548	150	114	284	310	335	264	630	183	367	80	95	140	14	110	

CENTRIFUGAL PUMPS

MAT83/2 PLUS



STANDARD EQUIPMENT

- Power Take Off for Water
- 3 Point Linkage
- 1: 6.3 Ratio

Description	Code	Price
Pump Centrifugal MAT83/2 Plus	LPMA832PLUS	5,702.80

SUITABLE RATIOS	IMPELLER R.P.M.	CAPACITY	PUMP HEAD (MT)	ABSORBED POWER (HP)
1: 6.3	2800	500	118	27.5
		1000	114	38
		1500	102	52
		2000	80	57
	2900	500	145	33.5
		1000	143	48
		1500	134	68
		2000	110	75
	3200	500	174	40
		1000	172	58
		1500	166	98
		2000	146	98

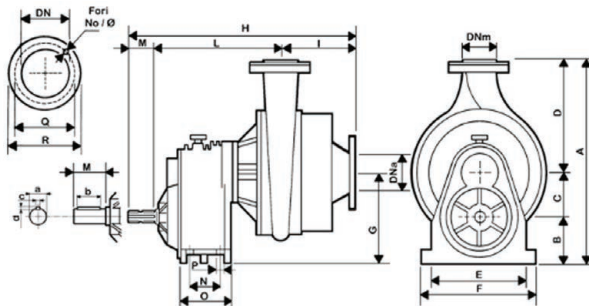
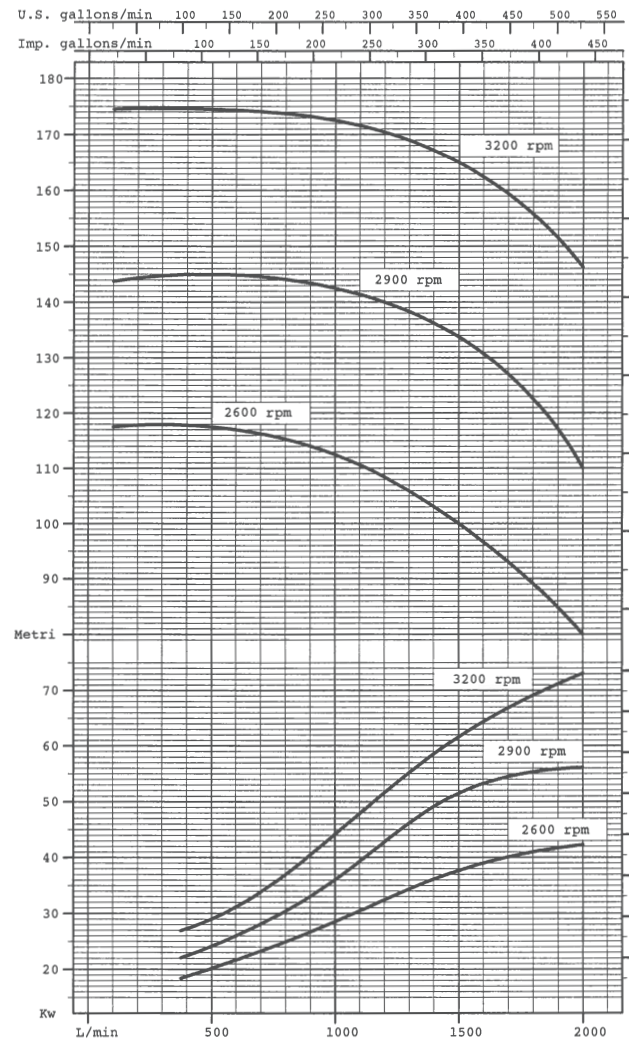

DIMENSIONS

SIZE (cm)															
A	B	C	D	E	F	G	H	I	L	M	N	O	P	Q	
520	150	114	256	310	335	264	550	117	353	80	95	140	16	87	

CENTRIFUGAL PUMPS

MAT120 PLUS



STANDARD EQUIPMENT

- Power Take Off for Water
- 3 Point Linkage
- 1: 6.3 Ratio

Description	Code	Price
Pump Centrifugal MAT120 Plus	LPMAT120PLUS	4,632.20

SUITABLE RATIOS	IMPELLER R.P.M.	CAPACITY	PUMP HEAD (MT)	ABSORBED POWER (HP)
1: 6.3	3000	800	105.6	32
		1600	108	58
		2400	101.6	77.16
	3200	800	118.3	32
		1600	121	65
		2400	114	91
	3400	800	135.2	44
		1600	138.4	75
		2400	133.6	109

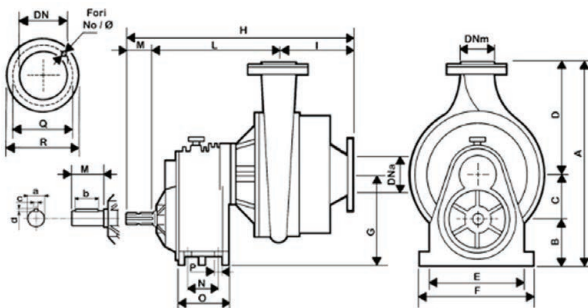
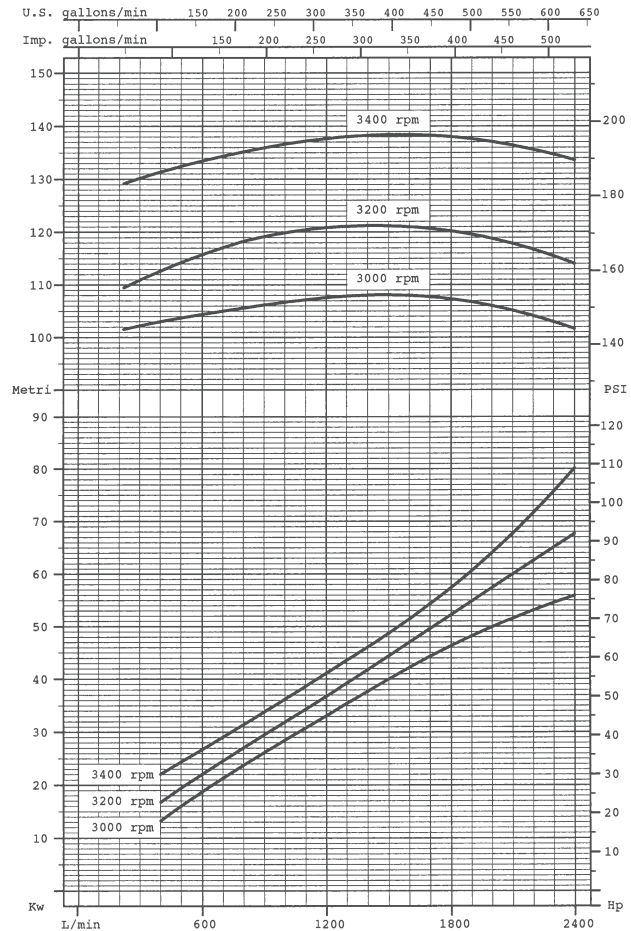

DIMENSIONS

SIZE (cm)															
A	B	C	D	E	F	G	H	I	L	M	N	O	P	Q	
550	150	120	280	310	335	270	560	123	360	80	95	14	16		

CENTRIFUGAL PUMPS

CENTRIFUGAL PUMPS

MAT125



STANDARD EQUIPMENT

- Power Take Off for Water
- 3 Point Linkage
- 1: 6.3 Ratio

Description	Code	Price
Pump Centrifugal MAT125	LPMA125	4,796.50

SUITABLE RATIOS	IMPELLER R.P.M.	CAPACITY	PUMP HEAD (MT)	ABSORBED POWER (HP)
1: 6.3	3400	2000	109	71
		2500	104	84
		3000	100	99.5
		3500	93	110
	3600	2000	124	86
		2500	120	100
		3000	116	111
		3500	110	125
	3800	2000	138	96
		2500	136	114
		3000	132	128
		3500	125	142

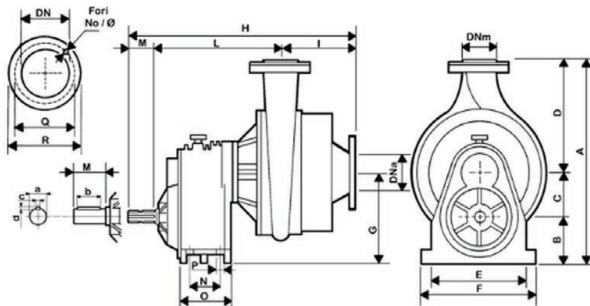
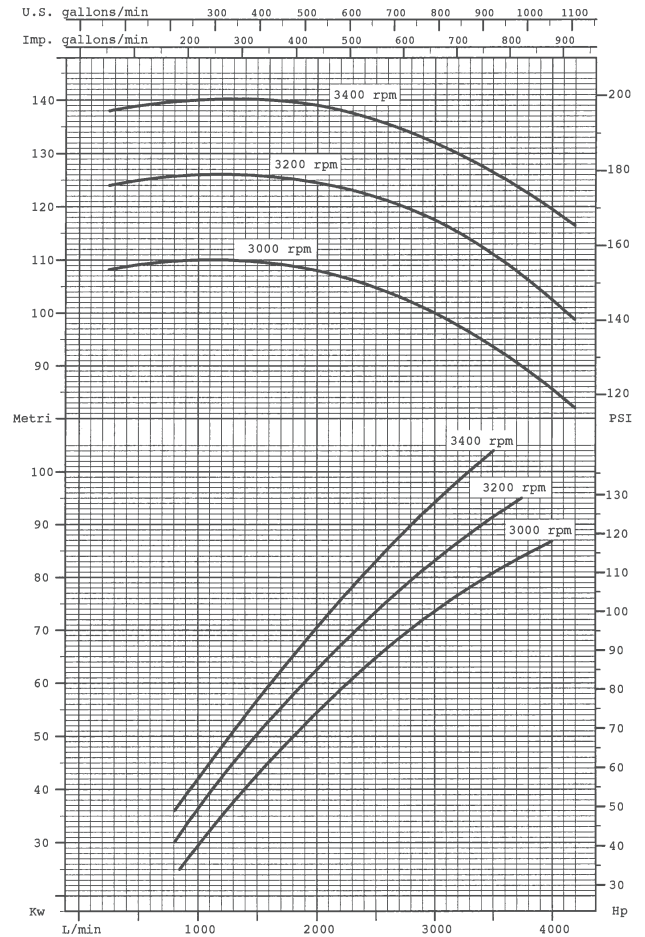

DIMENSIONS

SIZE (cm)															
A	B	C	D	E	F	G	H	I	L	M	N	O	P	Q	
520	145	125	250	310	335	270	555	121	356	80	95	140	16		

DIGITAL IRRIGATION EQUIPMENT



Offering a wide range of Digital Irrigation Equipment from leading brands to service your needs.



The **best way** to connect **your** irrigation systems

DIGITAL IRRIGATION 4.0



Why Digital Irrigation 4.0?

The Digital Irrigation 4.0 system grants a completely integrated management in which the user can analyse and manage with a single interface. The portal is "hosted" on the Cloud.

Field devices exchange data with a webserver continuously. An artificial intelligence analyses the data and provides the user with all the information they need to manage their irrigation.

The humidity sensors inform the user to the state of the soil and combined with weather forecasts, indicate where, when and how to irrigate.



DIGITAL IRRIGATION 4.0

The Marani digital irrigation system analyses and conveys your irrigation scenario to the mobile device of your choice.

Location of the machines, lines to be travelled during the work phases and a volume of processed information that suggests how much water to distribute and where. As the weather and ground moisture conditions change, the software reworks the parameters and provides the new situation. Your intervention is as timely as using your fingers to press a button on the touch display.



INCOMING DATA, OUTGOING INFORMATION

The system has sensors that detect the status of the terrain and the weather situation. The data is transmitted to a cloud server that processes it, transforming it into precise irrigation recommendations, and sends it to the operator's device (smartphone, tablet or PC workstation).



CONTROL OF IRRIGATORS IN THE FIELD

The machines follow the trajectories drawn up by the operator in advance. As the data flows in, and the irrigation scenario changes, it is possible to intervene on aspects such as water pressure or re-entry speed. The system provides a detailed report that can be consulted in real-time.

Description	Code	Price
Router setup for Ma-Rain 56 CL20	35400262	10,426.50



GPS-Fleet Management for your Irrigation Equipment

WHAT ARE THE BENEFITS OF A RAINDANCER® SYSTEM?



OVERVIEW

At any time, display the maps or the list of machines on your smartphone or pc. Machine location, water application, current water pressure and finish time.



CONTROL

Irrigation machines can be started and stopped from anywhere. If it starts to rain or it is too hot at noon - just stop from your smartphone. The speed can be adjusted automatically according to stored soil conditions.



NOTIFICATION

If the machine does not move or the pressure is too low, too high, a text message is sent. Also, upon entering critical zones - e.g. roads or railway lines on impact edge you will be notified via SMS.

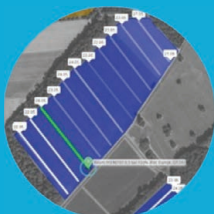

SCHEDULING

Irrigation runs are shown with detailed information and colour coordinated - planning your next irrigation movements.



PUMPS

Start and stop pumps via smartphone. In irrigation pipelines, Raindancer automatically switches the pumps on and off. If you have a frequency controlled pump, Raindancer can adjust the parameters dynamically.

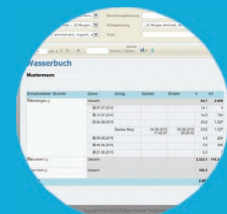

REPORTS

All data about your irrigation is saved in a database automatically. It is permanently available - reports produced showing water application by hose reel, field or crop. Data may be exported to MS Excel and processed there.



RAINDANCER

RAINDANCER



THE GPS MODULE

The raindancer module is built from an heavy-duty polycarbonite casing and a solar panel covered with a special. It is highly splash water and dust resistant. The complete assembly is mounted on a corrosion resistant aluminium platform. This platform makes mounting to your gun carriage very easy.

Besides the strong solar panel there is also a 4.000 mAh built-in battery. This combination makes a non-stop usage throughout a complete season possible.



SECTOR CONTROL

Thanks to various starting programs, classic pre-irrigation is no longer necessary.

The angles are set automatically according to field shape or obstacles and readjusted at any time.

If the irrigation run is narrowed, the speed is adjusted according to the irrigated area.*

You are in full control at all times, as a manual operating mode with remote control via app is also possible. This is helpful, for example, in changing wind conditions.



THE BEACON

Bring your pumps into the Raindancer portal. The Beacon allows your pump to communicate over the Internet. This can be done by using mobile networks or an existing LAN of your pump.

Monitor your pump in real time and know the exact status of your devices. (flow rate, meter reading, power, pressure)

Use remote control to take action. If necessary, they can start, stop or adjust the pressure. If a malfunction occurs during operation, you will be notified.

Description	Code	Price
Module with GPS Sender and Solar Panel	RD0009KIT	3,710.00
PRO - Module with GPS Sender and Solar Panel	RD0009-PROKIT	4,165.80
Beacon Set with M2M Router	RD0090KIT	3,052.80
Electronic Sector Adjustment	RD0040KIT	10,451.60
Mounting kit for GPS transmitter with solar module	RD9012	95.40

MA Rain 26 COMPUTER



The MA-Rain 26 computer features the following programmable functions:

- Working speed in mt\h or ft\h.
- Delayed start (in minutes) before retraction starts.
- Delayed stop (in minutes) before opening or closing the discharge valve (optional) or the shut-off valve.

The monitor then indicates:

- Remaining working time in hours and minutes.
- Working speed in mt\h or ft\h.
- Meters\feet of unwound hose.



MA Rain 56 COMPUTER



**PROUD TO
BE YOUR
PARTNER IN
IRRIGATION**

The MA-Rain 56 computer features the following:

- Compact case.
- 4" high contrast, colour display.
- Optical encoder, for a fast selection of settings.
- 2 x 4 keys for navigation with back lighting.
- Additional keys for alarm setting.
- I/O control module.
- On/Off key.
- Commands and features have an intuitive graphical user interface, to avoid keys in the lingo.
- Detailed alarm chart, with explicit reference to the components.
- Fast and easy parameters' /datas' settings.

CONSOLE RAIN COMPUTERS

Need to replace or upgrade your old MaterMacc Computer System?

CONSOLE RAIN 130



The Startec Console Rain 130 computer features the following:

- Allows the rewinding speed adjustment only by turning the knob on the desired speed.
- From 5 to 95 m/h (20-295 ft/h).
- It has to be connected to a roller speed sensor and to speed the adjustment motor.
- Power supplied by a 12 Volt battery.

The three leds indicate:

- The sensor functioning
- The adjustment motor functioning
- The battery charge

CONSOLE RAIN 260



Electronic control unit with back-lit LCD and 10 function-keys. It has to be linked to a system and to the speed adjustment motor and to an end-irrigation sensor. Power supplied with 12 Volt, by a battery.

Main Functions include:

- Measure of unwound hose
- Start irrigation/End irrigation
- Initial pause
- Rewinding at programmed speed, or programmed quantity (mm)
- Final pause

Main Options include:

- GSM
- Flowmeter control of system



The most widely used control unit in the sector. Extremely reliable. With just the starting of the motor pump, the CEM-250/10 automatically monitors all its parameters and alarms, with no operator adjustment. It is supplied with the electronic probe for the pump. Suitable for mounting directly on the motor pump.

Unit for Control and Protection for **IRRIGATION MOTOR PUMPSETS**



On the panel the functions are:

- Hour-meter
- Oil pressure gauge
- Water or oil thermometer
- Tachometer
- Pump water pressure gauge
- Timer
- Fuel level gauge
- Pump protection exclusion
- Battery and oil lights
- Protections intervention
- Emergency stop



Recent control unit made with functions similar to the CEM-250/10, but simplified.

With just the starting of the motor pump, the CEM-380 automatically monitors all its parameters and alarms, with no operator adjustment. It is supplied with the electronic probe for the pump. Suitable for mounting directly on the motor pump.



Unit for Control and Protection for IRRIGATION MOTOR PUMPSETS

Key Features Include:

- Digital instruments (hour-meter, timer, pump water pressure gauge, fuel level indicator, tachometer, battery voltmeter).
- Motor pump failure automatic monitoring (low oil pressure, over-temperature, belt breakage, minimum fuel level, available A1, A2 (low diesel fuel pressure), low coolant level, insufficient pump water pressure, pump water overpressure).
- Manual starting with key.
- Battery and oil lights.
- Pump protection exclusion.
- Accompanied by an electronic transmitter of water pressure.

Unit for Control and Protection for IRRIGATION MOTOR PUMPSETS

Control units that as well as manual operator control also allow its automatic control by external contact. With just the starting of the motor pump, the CIM-131 automatically monitors all its parameters and alarms, with no operator adjustment.

If connected to the actuator, installed on the accelerator of the diesel engine, these carry out automatic regulation to keep the irrigation pressure constant.

They are supplied with the electronic probe for the pump.



Key Features

- Digital instruments (hour-meter, oil pressure gauge, water or oil thermometer, timer, pump water pressure gauge, fuel level indicator, tachometer, battery voltmeter).
- Adjust engine speed through the actuator (on request) maintaining constant the pressure of the irrigation system.
- Controls the flow of water in the pipe.
- Motor pump failure automatic monitoring (low oil pressure, overtemperature, belt breakage, minimum fuel level, available A1, low diesel fuel pressure, low coolant level, insufficient pump water pressure, pump water overpressure).
- Remote control (start and stop).
- Clock for programming the start and stop of the machine.
- Acceleration and deceleration automatically adjusted upon starting and stopping of the pump.
- Frost protection and pressure boost functions.
- Battery and oil lights.
- Pump protection exclusion.
- Accompanied by an electronic transmitter of water pressure.



Unit for Control and Protection for IRRIGATION MOTOR PUMPSETS

Control units that as well as manual operator control also allow its automatic control by external contact. Also, the CIM-137/4GW has in addition the integrated modem-GSM 4G that allows remote control by app, browser or SMS.

With just the starting of the motor pump, the CIM-137/4G automatically monitors all its parameters and alarms, with no operator adjustment. If connected to the actuator, installed on the accelerator of the diesel engine, these carry out automatic regulation to keep the irrigation pressure constant. They are supplied with the electronic probe for the pump. Suitable for mounting directly on the motor pump, both flush mounted and with their possible independent bracket.

OTHER FEATURES INCLUDE

- Digital instruments (hour-meter, oil pressure gauge, water or oil thermometer, timer, pump water pressure gauge, fuel level indicator, tachometer, battery voltmeter).
- Adjust engine speed through the actuator (on request) maintaining constant the pressure of the irrigation system.
- Controls the flow of water in the pipe.
- Motor pump failure automatic monitoring (low oil pressure, over-temperature, belt breakage, minimum fuel level, available A1, low diesel fuel pressure, low coolant level, insufficient pump water pressure, pump water overpressure).
- Remote control by app, browser or SMS.
- Clock for programming the start and stop of the machine.

HOSE, GUNS & SPRINKLERS



An irrigator is not complete without all the extras and at Rodney Industries, we have a great selection of irrigation hose as well as leading brands of guns and sprinklers.



FLOWMASTER

IRRIGATION HOSE



Flowmaster is a flexible layflat drag hose for all types of irrigation applications.

CONSTRUCTION

Flowmaster comprises a circular woven high tenacity polyester reinforcement totally encapsulated in a tough elastomeric polyurethane cover and lining. Designed to fit a wide range of coupling types.

BOOSTS REELER CAPACITY

Unique 'fine weave' one-piece construction maximises reeler capacity.

FLEXIBILITY

Flowmaster is available in standard lengths of 200 meters and longer lengths up to 400 meters. It is the premium irrigation hose solution for both travelling irrigators and linear irrigation systems

LONG SERVICE LIFE

Designed for long service life with minimal maintenance. Tough and durable polyurethane cover with exceptional resistance to abrasion, cutting, ozone, UV, weathering and microbiological attack. Excellent in tropical climates.

OPERATING PERFORMANCE

Flowmaster is steamed to size which minimizes snaking and ensures the hose coils back easily after use. With a maximum swell of only 6% at normal operating pressure level of 7 bar, unacceptable hose contraction and excessive weight is severely reduced or eliminated.

FAST DEPLOYMENT AND RETRIEVAL

Superior handling; quick and easy to deploy and retrieve long continuous lengths without twisting, using light duty reels.

QUALITY AND RELIABILITY

Flowmaster is manufactured in compliance with BS EN ISO 9001: 2008 quality management system. Raw materials, components and finished products are rigorously tested and inspected to ensure excellent product reliability. Meets ASAE 394.

LOW OPERATING COSTS

Highly flexible for minimum pressure loss and maximum hydraulic efficiency.

WARRANTY DETAILS

For details on Angus Flexible Pipelines warranty, please refer to page 9 of our General Details.

Nominal Technical Specification

Diameter	3" 76mm	3½" 89mm	4" 102mm	4½" 114mm	5" 127mm	6" 152mm
Standard Supply Length	200	200	200	200	200	200
Weight	.75	.85	1.1	1.4	1.6	1.7
Nominal flat width	125	150	170	185	210	245
Minimum burst pressure	42	42	34	34	34	34
Maximum working pressure	21	21	17	17	17	17
Minimum tensile strength (tonne)	4.5	5.3	7.0	10.0	12.0	14
Nominal Wall Thickness	2.7	2.7	3.1	3.1	3.2	3.9
Operating Temperature range	-50 to +50	-50 to +50	-50 to +50	-50 to +50	-50 to +50	-50 to +50

Angus Flowmaster Hose - 3"

Size	Hose Size	Code	Price
76mm I.D	3" x 1m	25030APU	46.70
	3" x 150m	25031APU	5,918.60
	3" x 200m	25032APU	7,891.40

Angus Flowmaster Hose - 3½"

Size	Hose Size	Code	Price
90mm I.D	3½" x 1m	25035APU	POA
	3½" x 150m	25036APU	6,734.40
	3½" x 200m	25037APU	8,978.00

Angus Flowmaster Hose - 4"

Size	Hose Size	Code	Price
102mm I.D	4" x 1m	25075APU	51.10
	4" x 200m	25042APU	11,034.50
	4" x 250m	25044APU	15,172.50
	4" x 300m	25041APU	18,207.00

Angus Flowmaster Hose - 4½"

Size	Hose Size	Code	Price
114mm I.D	4½" x 1m	25045APU	63.60
	4½" x 200m	25047APU	16,037.60
	4½" x 300m	25053APU	24,055.40

Angus Flowmaster Hose - 5"

Size	Hose Size	Code	Price
127mm I.D	5" x 1m	25050APU	79.50
	5" x 200m	25090APU	17,147.10

Angus Flowmaster Hose - 6"

Size	Hose Size	Code	Price
152mm I.D	6" x 1m	25095APU	118.70
	6" x 200m	25091APU	P.O.A

SPRINKLERS & GUNS GUIDE

SPRINKLERS & GUNS



At Rodney Industries we offer Nelson, SIME and Komet sprinklers and guns. Listed below are the equivalents for each product.

For performance charts or further details on any of the sprinklers \ guns listed below, please contact our Sales Department on 07 3624 0300 or via email sales@rodneyind.com.au.

		Nelson						
		F70	F80	P85	SR75	SR100	SR150	SR200
SIME – Impact	Funny	■						
	K1		■					
	Ambo			■				
	Hidra			■	Komet 101 Vari			
	Duplex			■	Komet 101 Vari			
	Royal				Komet 101 Vari			
	Reflex					Komet 160		
	Quasar (Vari-angle)					160 VARI		
	Konkord (Vari-angle)					Komet 160	Komet 202 Vari	
	Explorer						Komet 202	
	Kronos (Vari-angle)						Komet 160 Vari	Komet 202 Vari
SIME – Gear Drive	Luxor				■			
	Skipper				■			
	Mariner					■		
	Mariner (2-speed)					■		
	Gemini (2-speed)						■	



BIG GUN

ENGINEERED SIMPLICITY,
PROVEN DURABILITY.

FOR OVER 4 DECADES, NELSON IRRIGATION HAS BEEN MANUFACTURING "THE ORIGINAL" BIG GUN® SPRINKLER.

Nelson pioneered the concept of a slow, steady, and uniform forward and reverse drive action, and the Big Gun's drive vane automatically compensates through a full range of nozzle sizes and pressures. A simple, reliable adjustment allows you to set the arc to within 1 degree without overriding the stops; a setting that will not change over time, as proven by years of use in the field.



NELSON IRRIGATION

NELSON IRRIGATION

BIG GUNS®

In the field of large-volume sprinklers, Nelson Big Guns® are recognized the world over as the leader in quality and performance. They are engineered and precision manufactured for heavy-duty reliability and long wear life with minimum maintenance required. Every Nelson Big Gun® is subjected to the toughest inspection testing and quality control standards in the industry.



75 SERIES



100 SERIES



150 SERIES



200 SERIES

Sprinkler	Nozzle Size & Range			Mounting Thread or Flange	Flow
	Primary	Secondary	Radius		
75 Series	10.2 – 20.3mm	-	#23.5 – 43.5m	Flange PCD 102mm	110 – 618 L/M
100 Series	12.7 – 25.4mm	5.6 – 8mm	*# 29.75 – 58m	Flange PCD 102mm	180 – 1170 L/M
150 Series	17.8 – 35.6mm	5.6mm – 10.3mm	*# 38 – 74.5m	Flange PCD 146mm & 130mm	383 – 2466 L/M
200 Series	26.7 – 48.3mm	5.6 – 10.3mm	* 52 – 94m	Flange PCD 146mm	930 – 4560 L/M

* Taper bore nozzle used. Ring nozzles radius will be less
 # BSP Thread mounting available upon request.

NELSON IRRIGATION



75 Series

Size	Code	Price
Part Circle – Slow Reverse Big Gun (without Nozzle)	SR75	2,048.20
Individual Taper Ring Nozzle – Specify Size, Choice of 9 (10.2mm to 20.3mm)	75TR	64.70



100 Series

Size	Code	Price
Part Circle – Slow Reverse Big Gun (without Nozzle)	SR100	2,610.00
Part Circle – Slow Reverse Big Gun Complete	SR100K	2,879.20
Part Circle – Slow Reverse – Adjustable Trajectory (without Nozzle)	SRA100	POA
Taper Bore Nozzle – Specify Size (choice of 10)	100T	146.30
Ring Nozzle Set – Cap, Body & 7 Rings	100R	248.00



150 Series

Size	Code	Price
Part Circle – Slow Reverse – Flange or ANSI Flange (without Nozzle)	SR150	4,512.00
Part Circle – Slow Reverse Big Gun Complete	SR150K	4,974.40
Part Circle – Slow Reverse – Adjustable Trajectory (without Nozzle)	SRA150	5,653.20
Part Circle – Slow Reverse – Flanged Connection Stainless Steel (Includes Nozzle)	SR150SS	15,022.40
Taper Bore Nozzle – Specify Size	150T	249.10
Ring Nozzle Set – Cap, Body & 7 Rings	150R	406.10



200 Series

Size	Code	Price
Full Circle – Flange (without Nozzle)	F200	5,420.50
Part Circle – Slow Reverse – Flanged Connection (without Nozzle)	SR200	7,047.50
Part Circle – Slow Reverse Big Gun Complete	SR200K	7,721.90
Taper Bore Nozzle – Specify Size	200T	312.70
Ring Nozzle Set & 7 Rings	200R	599.60

IMPACT SPRINKLERS

For quality manufactured sprinklers why not choose a Nelson Impact Sprinkler.
For performance details on the following sprinklers, please contact our Sales Department.



NELSON F70V



NELSON F80V



NELSON P65



NELSON P85

Sprinkler	Nozzle Size & Range		Radius	Mounting Flange	Flow
	Primary	Secondary			
F70V	7/32 – 13/32	7/64 – 5/16	16.5m – 26.2m	25mm BSPM*	29 – 146.6 L/M
F80V	11/32 – 5/8	7/64 – 5/16	20.1m – 36m	32mm BSPM*	82.5 – 410 L/M
P65 (part circle)	7/32 – 3/8	n/a	15.5m – 25.3m	25mm BSPM*	28.57 – 129 L/M
P85 (part circle)	11/32 – 11/16	n/a	21m – 35m	32mm BSPM*	82.5 – 439 L/M

* BSP thread mounting available upon request.

Sprinkler Nelson

Size	Code	Price
F70V (Less Nozzles)	19026	427.90
F80V (Less Nozzles)	18994	715.70
P65 (Less Nozzles)	18914	408.90
P85 (Less Nozzles)	18783	905.00



As seen on Rodney Industries' RI Range Travelling Irrigators

sime



*As seen on
Rodney Industries'
Marani Hard Hoses*



**For small to large scale
irrigation we have a
sprinkler and gun to suit.**





SIME IRRIGATION

SIME GUNS

Sprinklers of middle or high capacity and pressure rotating at full circle or parts circle, with slow return. Particularly suitable for all types of watering machines can be used also for centre pivots and normal installations. An intermittent and adjustable jet-breaker working only on the return, allows the user to get a uniform distribution of rain fall all over the irrigated area.



ROYAL
(16, 18, 20, 22mm nozzles included)



REFLEX
(24, 26, 28, 30, 32mm nozzles included)



EXPLORER
(28, 30, 32, 34, 36, 38, 40mm nozzles included)



LUXOR
(10, 12, 14, 16mm nozzles included)



SKIPPER (GEAR DRIVE)
(14, 16, 18mm nozzles included)



MARINER (GEAR DRIVE)
(28, 30, 32mm nozzles included)



MARINER 2 SPEED
(28, 30, 32mm nozzles included)



GEMINI 2 SPEED
(34mm nozzle included)

Size	Nozzle Size & Range			Flow LPM	Mounting Threaded or Flanged	Code	Price
	Primary	Secondary	Radius-Mets				
Royal	12-24mm	-	22-51	110-882	63mm BSPF	140036KIT	1,589.00
Reflex	16-34mm	-	32-65	276-1913	FL130 PCD	140052KIT	1,608.00
Explorer	22-40mm	-	40-78	522-2834	FL130 PCD	140055KIT	2,156.30
Luxor	10-18mm	4mm	20.5-35	102-496	40mm BSPF	140063KIT	POA
Skipper	10-20mm	6mm	28-57	120-609	40mm BSPF	140065KIT	1,024.70
Mariner	18-34mm	8mm	48-122	343-2162	63mm BSPF	140075KIT	2,197.10
Mariner 2 Speed	18-34mm	8mm	48-122	343-2162	63mm BSPF	140080KIT	2,429.50
Gemini 2 Speed	28-46mm	9mm	51-90	1082-4481	FL 130 & 145 PCD	140085KIT	2,920.30

SIME GUNS



Sime offer a range of small and medium capacity sprinklers for full or part circle operation, equipped with an adjustable jet breaker which allow a good rainfall all over the wetted area. They are suitable for irrigating mixed crops, orchards, fruits, gardens, playgrounds and frost protection.



JUNIOR
(4mm nozzle included)



SILVER
(8, 6, 7mm nozzles included)



JOLLY
(8, 9, 10, 12, 14mm nozzles included)



FUNNY PART CIRCLE
(6, 7mm nozzles included)



K1 8° PART CIRCLE
(8, 9, 10mm nozzles included)



K1 24° PART CIRCLE
(8, 9, 10mm nozzles included)



HIDRA PART CIRCLE
(12, 14, 16mm nozzles included)



DUPLEX PART CIRCLE
(14, 16, 18mm nozzles included)

Size	Nozzle Size & Range			Flow LPM	Mounting Threaded or Flanged	Code	Price
	Primary	Secondary	Radius-Mets				
Junior	4mm	-	11-13.5	10.8-15	12.7mm BSPM	140002	51.00
Silver	5-7mm	-	12-17	20-60	20mm BSPM	140004	102.00
Jolly	7-16mm	4mm	14-29	71-311	32mm BSPF	140006	229.30
Funny Part Circle	5-10mm	-	12.5-19.5	20-100	25mm BSPF	140000	127.40
K1 8° Part Circle	6-14mm	-	15.5-23.5	49-179	32mm BSPF	140008	224.80
K1 24° Part Circle	6-14mm	-	15.5-23.5	49-179	32mm BSPF	140010	185.40
Hidra Part Circle	10-18mm	5mm	18-36.5	110-651	40mm BSPF	140020	312.80
Duplex Part Circle	12-22mm	8mm	20-46.5	159-839	50mm BSPF	140030	613.40



SIME IRRIGATION

NOZZLE SETS

Once you have decided upon your SIME Gun, the next step is to choose the nozzle set. If you are unsure, or would like further information, please do not hesitate in contacting our Sales Department.

Nozzles to suit SIME Junior

Size	Code	Price
4mm	30619	3.00

Nozzles to suit SIME Silver

Size	Code	Price
5mm	140205	6.90
6mm	140206	6.90
7mm	140207	6.90

Nozzles to suit SIME Funny

Size	Code	Price
5mm	140405	6.50
6mm	140406	6.50
7mm	140407	6.50
8mm	140408	6.50
9mm	140409	6.50
10mm	140410	6.50

Nozzles to suit SIME K1, Luxor & Jolly

Size	Code	Price
6mm	140506	8.30
8mm	140508	8.30
9mm	140509	8.30
10mm	140510	8.30
12mm	140512	8.30
14mm	140514	8.30
16mm	140516	22.10
18mm	140518	8.30

Nozzles to suit Gemini (Aluminium)

Size	Code	Price
28mm	94528	55.10
30mm	94530	58.30
32mm	94532	58.30
34mm	94534	55.10
36mm	94536	55.10
38mm	94538	58.30
40mm	94540	58.30
44mm	94544	55.10

Nozzles to suit SIME Hidra

Size	Code	Price
10mm	140610	8.00
12mm	140612	8.00
14mm	140614	8.00
16mm	140616	8.00
18mm	140618	8.00

Nozzles to suit SIME Duplex & Skipper

Size	Code	Price
10mm	140710	10.80
12mm	140712	10.80
14mm	140714	10.80
16mm	140716	10.80
18mm	140718	10.80
20mm	140720	10.80
22mm	140722	10.80
24mm	140724	10.80

Nozzles to suit SIME Royal, Reflex, Explorer, Mariner & Gemini (Plastic)

Size	Code	Price
16mm	140816	19.20
18mm	140818	19.20
20mm	140820	19.20
22mm	140822	19.20
24mm	140824	19.20
26mm	140826	19.20
28mm	140828	19.20
30mm	140830	19.20
32mm	140832	19.20
34mm	140834	19.20
36mm	140836	19.20
38mm	140838	19.20
40mm	140840	19.20
42mm	140842	19.20
44mm	140844	19.20
46mm	140846	19.20



komet

INNOVATIVE
IRRIGATION



the komet advantage

It is important that every irrigation system operates reliably in order to avoid yield losses, waste of energy with its associated costs but more than anything to optimise the soil potential. The gun not being continuously monitored, has to operate always at its best without the necessity of adjustments or maintenance.



KOMET GUNS



It is important that every irrigation system operates reliably in order to avoid yield losses, waste of energy with its associated costs but more than anything to optimise the soil potential. The gun not being continuously monitored, has to operate always at its best without the necessity of adjustments or maintenance.



TWIN 101



TWIN 140



TWIN 160



TWIN 202

Description	NOZZLE SIZE & RANGE		Mounting Flange	Flow LPM	Code	Price
	Primary	Radius				
Twin 101 Ultra 24' Kit	12 to 28mm	24.2 to 60.6m	Flange 6 x 10.5mm Holes PCD130mm	130 - 1320	5010253KIT	1,701.60
Twin 101 Ultra VA15-45' Kit	12 to 28mm	24.2 to 60.6m	Flange 6 x 10.5mm Holes PCD130mm	130 - 1320	5010271KIT	1,887.70
Twin 140 Ultra 24' Kit	16 to 34mm	29.0 to 68.7m	Flange 6 x 10.5mm Holes PCD130mm	230 - 1946	5010254KIT	1,966.70
Twin 140 Ultra VA15-45' Kit	16 to 34mm	29.0 to 68.7m	Flange 6 x 10.5mm Holes PCD130mm	230 - 1946	5010296KIT	2,340.30
Twin 160 Ultra 24' Kit	18.8 to 40mm	37.8 to 82.4m	Flange 6 x 10.5mm Holes PCD130mm	361 - 3076	5010255KIT	2,262.20
Twin 160 Ultra VA15-45' Kit	18.8 to 40mm	37.8 to 82.4m	Flange 6 x 10.5mm Holes PCD130mm	361 - 3076	5010304KIT	2,523.40
Twin 202 Ultra 24' Kit	22 to 45mm	41.5 to 90.0m	Flange 6 x 10.5mm Holes PCD130mm	540 - 3916	5010256KIT	2,390.90
Twin 202 Ultra VA15-45' Kit	22 to 45mm	41.5 to 90.0m	Flange 6 x 10.5mm Holes PCD130mm	540 - 3916	5010311KIT	3,538.10

NOZZLE SETS

Once you have decided upon your Komet Gun, the next step is to choose the nozzle set. If you are unsure, or would like further information, please do not hesitate in contacting our Sales Department.

Nozzles to suit Komet 101

Size	Code	Price
12mm / 0.47"	4010678	35.10
14mm / 0.55"	4010680	35.10
16mm / 0.63"	4010682	35.10
18mm / 0.71"	4010684	35.10
20mm / 0.79"	4010686	35.10
22mm / 0.87"	4010688	35.10
24mm / 0.94"	4010690	35.10
26mm / 1.02"	4010692	35.10
28mm / 1.10"	4010694	35.10

Nozzles to suit Komet 140

Size	Code	Price
16mm / 0.63"	4010682	35.10
18mm / 0.71"	4010684	35.10
20mm / 0.79"	4010686	35.10
22mm / 0.87"	4010688	35.10
24mm / 0.94"	4010690	35.10
26mm / 1.02"	4010692	35.10
28mm / 1.10"	4010694	35.10
30mm / 1.18"	4010696	35.10
32mm / 1.26"	4010698	35.10
34mm / 1.34"	4010700	35.10

Nozzles to suit Komet 160

Size	Code	Price
18mm / 0.71"	4010702	35.10
20mm / 0.79"	4010704	35.10
22mm / 0.87"	4010706	35.10
24mm / 0.94"	4010708	35.10
26mm / 1.02"	4010710	35.10
28mm / 1.10"	4010712	35.10
30mm / 1.18"	4010714	35.10
32mm / 1.26"	4010716	35.10
34mm / 1.34"	4010718	35.10
35mm / 1.38"	4010719	35.10
36mm / 1.42"	4010720	35.10
38mm / 1.50"	4010722	35.10
40mm / 1.57"	4010724	35.10

Nozzles to suit Komet 202

Size	Code	Price
22mm / 0.87"	4010706	35.10
24mm / 0.94"	4010708	35.10
26mm / 1.02"	4010710	35.10
28mm / 1.10"	4010712	35.10
30mm / 1.18"	4010714	35.10
32mm / 1.26"	4010716	35.10
34mm / 1.34"	4010718	35.10
35mm / 1.38"	4010719	35.10
36mm / 1.42"	4010720	35.10
38mm / 1.50"	4010722	35.10
40mm / 1.57"	4010724	35.10
42mm / 1.65"	4010726	35.10
44mm / 1.73"	4010728	35.10
45mm / 1.77"	4010729	35.10

SPRINKLERS & GUNS GUIDE

EXTENSION PIPES



Our range of Extension Pipes are the ideal way to adjust the flange pattern of your installation to your requirements. Enabling you to successfully connect your Big Gun to your irrigator or permanent installation.

Big Gun 4 Hole Multi Flange

Pipe Size	Overall Length (mm)	Code	Price
3" OD x 4mm Wall	100mm	25507	126.80
	560mm	25509	149.30
	750mm	25510	159.70
	1000mm	25511	171.30

Big Gun 4 Hole x 6 Hole Multi Flange

Pipe Size	Overall Length (mm)	Code	Price
3" OD x 4mm Wall	100mm	25517	135.80
	560mm	25518	159.70
	750mm	25520	170.00
	1000mm	25522	184.20

Big Gun 4 Hole Multi Flange

Pipe Size	Overall Length (mm)	Code	Price
3.5" OD x 4mm Wall	100mm	25503	128.10
	560mm	25546	159.70
	750mm	25514	173.30
	1000mm	25515	191.30

Big Gun 4 Hole x 6 Hole Multi Flange

Pipe Size	Overall Length (mm)	Code	Price
3.5" OD x 4mm Wall	100mm	25545	137.10
	560mm	25526	170.00
	750mm	25527	185.60
	1000mm	25528	202.30

Big Gun 6 Hole Multi Flange

Pipe Size	Overall Length (mm)	Code	Price
3.5" OD x 4mm Wall	100mm	25582	147.40
	560mm	25584	182.30
	750mm	25586	195.90
	1000mm	25588	213.90

Nelson Flange SR100/SR100

Pipe Size	Overall Length (mm)	Code	Price
SR100	100mm	25550	119.50
	560mm	25532	143.50
	750mm	25533	154.60
	1000mm	25534	167.40

Big Gun 6 Hole Multi Flange

Pipe Size	Overall Length (mm)	Code	Price
4" OD x 4mm Wall	100mm	25590	147.40
	560mm	25592	185.60
	750mm	25594	199.70
	1000mm	25596	209.40

Nelson Flange SR150 / SR200

Pipe Size	Overall Length (mm)	Code	Price
4.5" OD x 4mm Wall	100mm	25537	109.20
	560mm	25539	157.10
	750mm	25541	177.00
	1000mm	25543	223.80

BIG GUN ADAPTORS

Rodney Industries supplies a wide range of Big Gun Adaptors. Not sure which one best suits your needs? Why not contact our Sales Department for assistance.



Big Gun Adaptors - Flange To Male Thread

Size	Code	Price
4H Big Gun Multi Flange to 2.5" BSPM	25552	97.00
4H Big Gun Multi Flange to 3" BSPM	25554	100.90
6H Big Gun Multi Flange to 2.5" BSPM	25556	108.00
6H Big Gun Multi Flange to 3" BSMP	25558	111.80



Big Gun Adaptors - Flange to Female Thread

Size	Code	Price
SR100 Flange to 2" BSPF	25523	64.00
SR100 Flange to 2.5" BSPF	25524	66.70
4H Big Gun Multi Flange to 3" BSPF	25568	123.50
6H Big Gun Multi Flange to 2.5" BSPF	76162	81.50
6H Big Gun Multi Flange to 3" BSPF	76164	82.70
6H Big Gun Multi Flange to 4" BSPF	25574	89.30
Big Gun Adaptor - Flange to Flange SR100 to 130 PCD (To Suit Marani Cart)	25521	122.80
Marani Sprinkler Adaptor, Sime 130mm PCD Flange x Nelson 146mm PCD Flange 100mm OD Pipe x 100mm Long Galv	25525	166.30



BIG GUN FLANGES (Black Weld On)

SIZE	ID SIZE	CODE	Price
Nelson SR100	2½"	25512	29.00
Nelson SR100	3"	25516	30.40
Nelson SR150	3"	25500	37.50
Nelson SR150	3½"	25504F	38.80
Nelson SR200	4"	25508	36.10
Nelson SR200	4½"	25508F	38.80
4H Big Gun Multi Flange	3"	25576	33.00
4H Big Gun Multi Flange	3½"	25576A	25.40
6H Big Gun Multi Flange	3½"	25578	41.30
6H Big Gun Multi Flange	4"	25580	41.30



Rodney Industries

RODNEY INDUSTRIES

19 Valente Close,
Chermside QLD 4032
Phone: +61 7 3624 0300



Connect with Us



Proudly a division of
Vinidex
by aliaxis